



www.raynendrive.com
 Customer Service Hotline: 400-0898-188

Raynen Makes Industry More Intelligent

工业自动化产品和解决方案专家



RVE32 Series Variable frequency drive

Version: V24.12

Raynen® 睿能
 Raynen Technology Co., Ltd.

ADD: No. 12, Zhihui Avenue, Nanyu Town, Minhou County, Fuzhou, China.
 TEL : 86-591-88267288

The sample version is constantly updated with product upgrades, please pay attention to the version number
 For products and solutions marked with *, please contact us for detailed information

Raynen Technology all rights reserved ©

Stock Code (Raynen Technology 603933)

Raynen® 睿能

About Raynen

2007

Raynen Technology was established

Main Board Listing

Listed on the main board of Shanghai Stock Exchange in 2017
Stock Code: 603933

It is a high-tech enterprise specializing in the research and development, production, sales and service of industrial automation products.

Innovation Strength

The company is headquartered in Fuzhou, with nearly 20 subsidiaries and R&D centers in Shanghai, Wuhan, Fuzhou and Changzhou. It is a "Key High-tech Enterprise of the National Torch Program", "Fujian Provincial Enterprise Technology Center", "China Textile Machinery Industry Computerized Flat Knitting Machine Intelligent Control System Product R&D Center", "Fujian Textile Equipment Intelligent Control Enterprise Engineering Technology Research Center", etc. The company insists on driving the development of technology and products with scientific and technological innovation, and through years of accumulation, has formed a number of core technologies and patent technologies with domestic leading level.

Business Area

As a domestic technology-leading supplier of industrial automatic control products, Ruineng Technology focuses on the research of control and drive technology. After years of product and technology cultivation, it has completed the comprehensive expansion from industry-specific electronic control systems to general automation products. The company's general automation products include core products such as AC servo systems, frequency converters, programmable controllers, human-machine interfaces, and Internet of Things gateways. They are widely used in electronics, textile machinery, machine tools, printing and packaging machinery, logistics equipment, intelligent manipulators, woodworking machinery, laser processing equipment, metallurgy, petroleum, and chemical industries. It provides equipment manufacturing companies with competitive products and personalized solutions with leading technologies.

Mission and Vision

Raynen has always taken "making industry smarter" as its mission, adhering to "honest cooperation, open innovation, customer achievement, world-class intelligent industrial automation products and solutions suppliers, to achieve the common growth of enterprise value and customer value.



RVE32 Variable frequency drive

Product summary



RVE32 Series High Performance Dual-Display VFD, which apply to 0.75~800kW three-phase asynchronous motor, has a unique book appearance structure design, rich function, stable performance. The series adopts advanced speed sensorless vector control technology, motor parameter identification technology, online estimation technology and flux estimation technology, which has greatly improved performance in the speed range, dynamic response, control accuracy and low frequency torque. It can be widely used in material handling, packaging, textile, lifting, material processing, wood processing, metal processing, fan and other industries.

Product features

- Compact structure design, saving installation space
- Clear terminal layout and wiring identification make installation easier
- Wide voltage range design ensures product adaptability to grid fluctuations
- Advanced independent air duct design, adaptable to various complex and harsh on-site environments
- E model supports synchronous motor control
- Modbus communication is standard, and models above 15kW have both RJ45 and separate terminal interfaces, making it easy to achieve system integration and network control
- In addition to single reading, single writing, and continuous reading and writing of continuous parameters, it can also realize continuous reading and writing of some scattered parameters, making it more convenient and efficient to use
- The motor is pre-magnetized before starting, and then the brake is opened by frequency, current, etc. to prevent the load from slipping due to insufficient torque.
- When multiple motors drive the same load, the load of each motor can be balanced by correcting the speed of some motors, thus extending the service life of the motors and equipment.
- By improving the response speed, the speed change during load disturbance is controlled to maintain the motor speed constant to the greatest extent possible

Product functions

Synchronous machines are highly adaptable

- Loop parameters, no debugging required.
- Motor parameters can be self-learned with one click.



Small harmonic interference

- Meet various electromagnetic environment requirements
- Standard built-in C3 filter
- The power module radiator has an independent air duct to reduce pollution to electronic devices.

Wide voltage design

The input voltage fluctuation range is $-15\% \sim +26\%$ of the rated voltage, which can protect the device from the impact of voltage fluctuations and meet the harsh power grid environment.

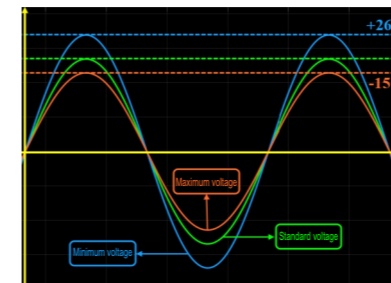

Double line display large panel

- The full keyboard double-line display panel can display current, voltage and other signals at the same time, with clear display and rich content.



Communication interface, flexible application

- Modbus communication is standard, and models above 15kW have both RJ45 and separate terminal interfaces, making it easy to achieve system integration and network control.
- In addition to single reading, single writing, and continuous reading and writing of continuous parameters, it can also realize continuous reading and writing of some scattered parameters, making it more convenient and efficient to use.

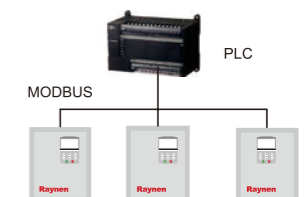

Instantaneous blackout protection

In case of instantaneous power failure or sudden decrease of input voltage, inertia energy of load side is fed back to DC bus by reducing motor speed to make up temporary energy gap, maintain DC voltage higher than undervoltage action value, and avoid shutdown due to undervoltage. This function is very effective in large inertia load applications such as centrifuges and transformers.

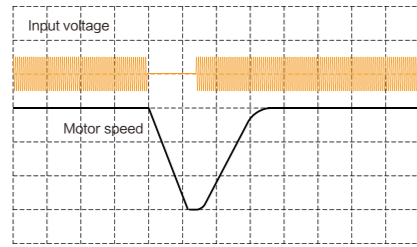

Reliable braking

- The motor is pre-magnetized before starting, and then the brake is opened by frequency, current, etc. to prevent the load from slipping due to insufficient action.
- As long as it is in advance, the brake is triggered in advance to ensure sufficient stability.
- Main applications: hoist systems, cranes, winches, etc.

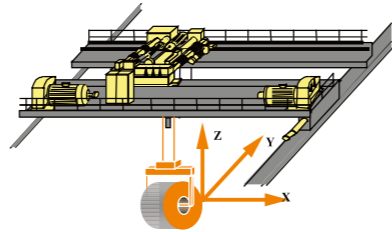

Rich built-in PID capabilities

Most loads such as fans, pumps, air compressors, boilers, central air conditioners, etc. have decreasing torque characteristics. They can be used as closed-loop control through PID adjustment. They are suitable for various sensors. The PID feedback signal can be voltage (0~5V/0~10V) or current (4~20mA).

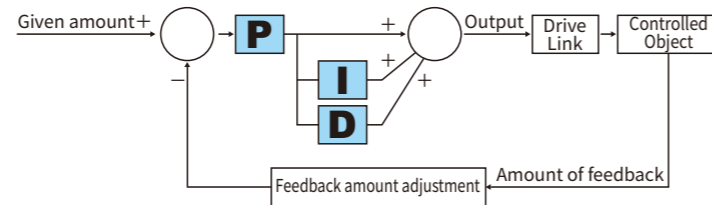

Application

Material handling, packaging, textiles, lifting, material processing, wood processing, metal processing, fans, etc.



Thermal Power Generation



Petrochemical



Coal Mine



Metallurgy



Cement Manufacturing

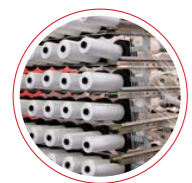

Textile



Packaging



Material handling



Wood processing



Fan and Water pump

Model description

RVE32 X - T3 - 7R5 G / 11 P
 ① ② ③ ④ ⑤ ④ ⑤

① Product Series RVE32: Raynen VFD Export	② Motor Type None: Asynchronous motor E: Permanent magnet synchronous motor	④ Adapted motor power 0R4 : 0.4kW 0R7 : 0.75kW 1R5 : 1.5kW 2R2 : 2.2kW 11 : 11kW 15 : 15kW
③ Supply Voltage S2: single-phase 220V T3: Three-phase 380V	⑤ Load Type G: Overload P: Light load	

Panel size

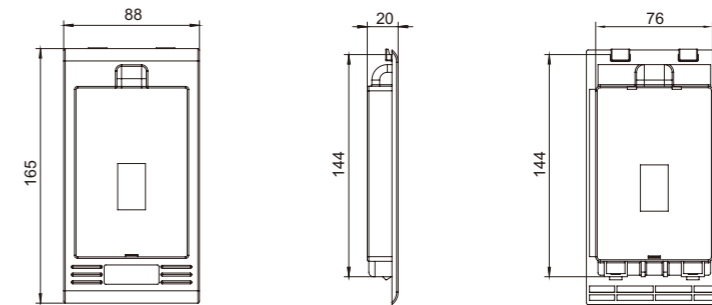

Appearance size

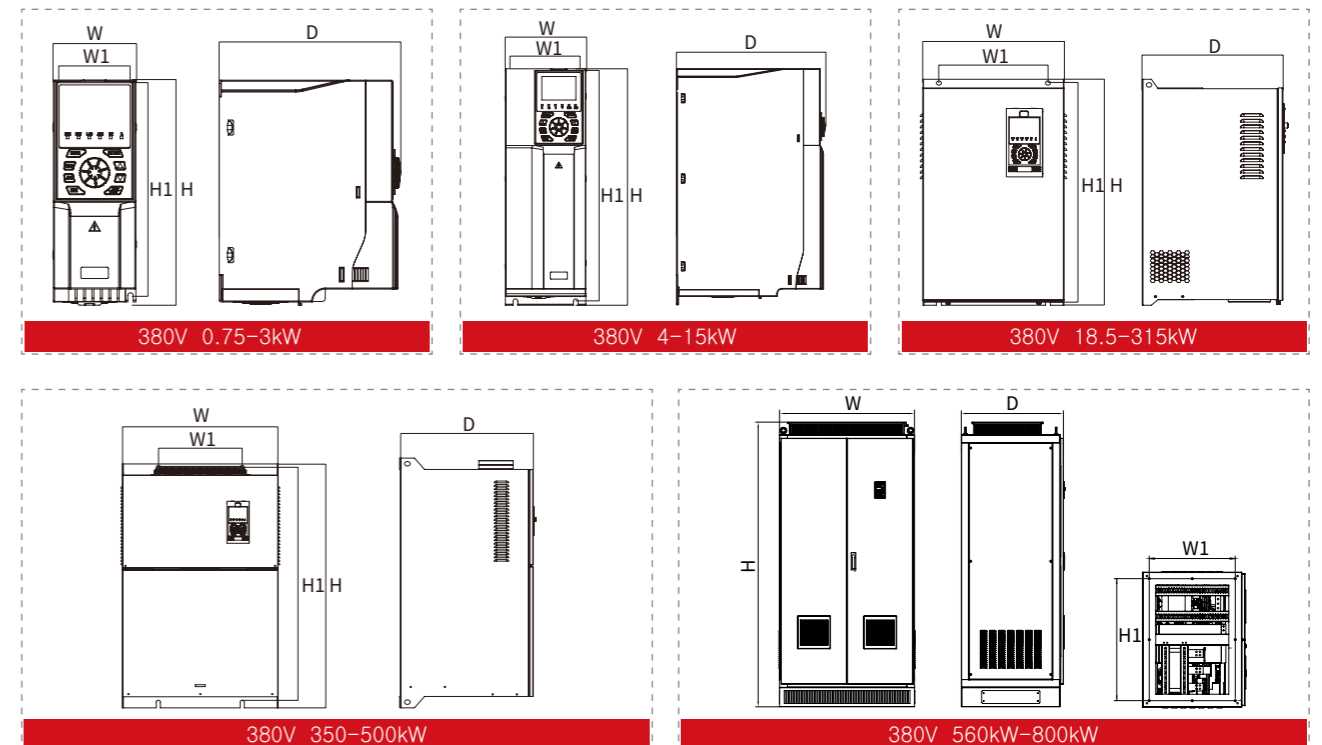

Model selection

Model (three-phase T3)	G Type (Heavy load)			P Type (Light load)			Dimension (H*W*D mm)	Installation size (H1*W1 mm)	Aperture
	Motor power (kW)	Rated input current(A)	Rated output current(A)	Motor power (kW)	Rated input current(A)	Rated output current(A)			
RVE32-T3-0R7G/1R5P	0.75	3.6	2.6	1.5	6.4	4.1	206*76.5*168.5	195*66.5	Φ5
RVE32-T3-1R5G/2R2P	1.5	6.4	4.1	2.2	8.7	5.5			
RVE32-T3-2R2G/3P	2.2	8.7	5.5	3	10.9	6.9			
RVE32-T3-3G/4P	3	10.9	6.9	4	14	9.5	262*100*171	251*90	Φ5
RVE32-T3-4G/5R5P	4	14	9.5	5.5	20.7	12.6			
RVE32-T3-5R5G/7R5P	5.5	20.7	12.6	7.5	26.5	18.5			
RVE32-T3-7R5G/11P	7.5	26.5	18.5	11	36.6	25	353*120*222	341*108	Φ7
RVE32-T3-11G/15P	11	36.6	25	15	40	32			
RVE32-T3-15G/18P	15	40	32	18.5	47	38			
RVE32-T3-18G/22P	18.5	47	38	22	56	45	327*168*185.6	313*120	Φ9
RVE32-T3-22G/30P	22	56	45	30	70	60			
RVE32-T3-30G/37P	30	70	60	37	80	75			
RVE32-T3-37G/45P	37	80	75	45	94	92	410*260*214	396*180	Φ9
RVE32-T3-45G/55P	45	94	92	55	128	115			
RVE32-T3-55G/75P	55	128	115	75	160	150			
RVE32T3-75G/90P	75	160	150	90	190	180	600*310*310	583*240	Φ11
RVE32-T3-90G/110P	90	190	180	110	225	215			
RVE32-T3-110G/132P	110	225	215	132	265	260			
RVE32-T3-132G/160P	132	265	260	160	310	305	720*355*345	698*240	Φ13
RVE32-T3-160G/185P	160	310	305	185	355	350			
RVE32-T3-185G/200P	185	355	350	200	385	380			
RVE32-T3-200G/220P	200	385	380	220	430	425	920*480*390	898*320	Φ13
RVE32-T3-220G/250P	220	430	425	250	485	480			
RVE32-T3-250G/280P	250	485	480	280	545	530			
RVE32-T3-280G/315P	280	545	530	315	610	600	1100*480*405	1078*320	Φ13
RVE32-T3-315G/355P	315	610	600	355	665	650			
RVE32-T3-355G	355	665	650	-	-	-			
RVE32-T3-400G	400	785	725	-	-	-	1100*650*465	1060*350	Φ17
RVE32-T3-500G	500	890	860	-	-	-			
RVE32-T3-560G	560	950	950	-	-	-			
RVE32-T3-630G	630	1100	1100	-	-	-	2200*1100*800	943*665	Φ16
RVE32-T3-710G	710	1280	1280	-	-	-			
RVE32-T3-800G	800	1380	1380	-	-	-			

Standard wiring diagram

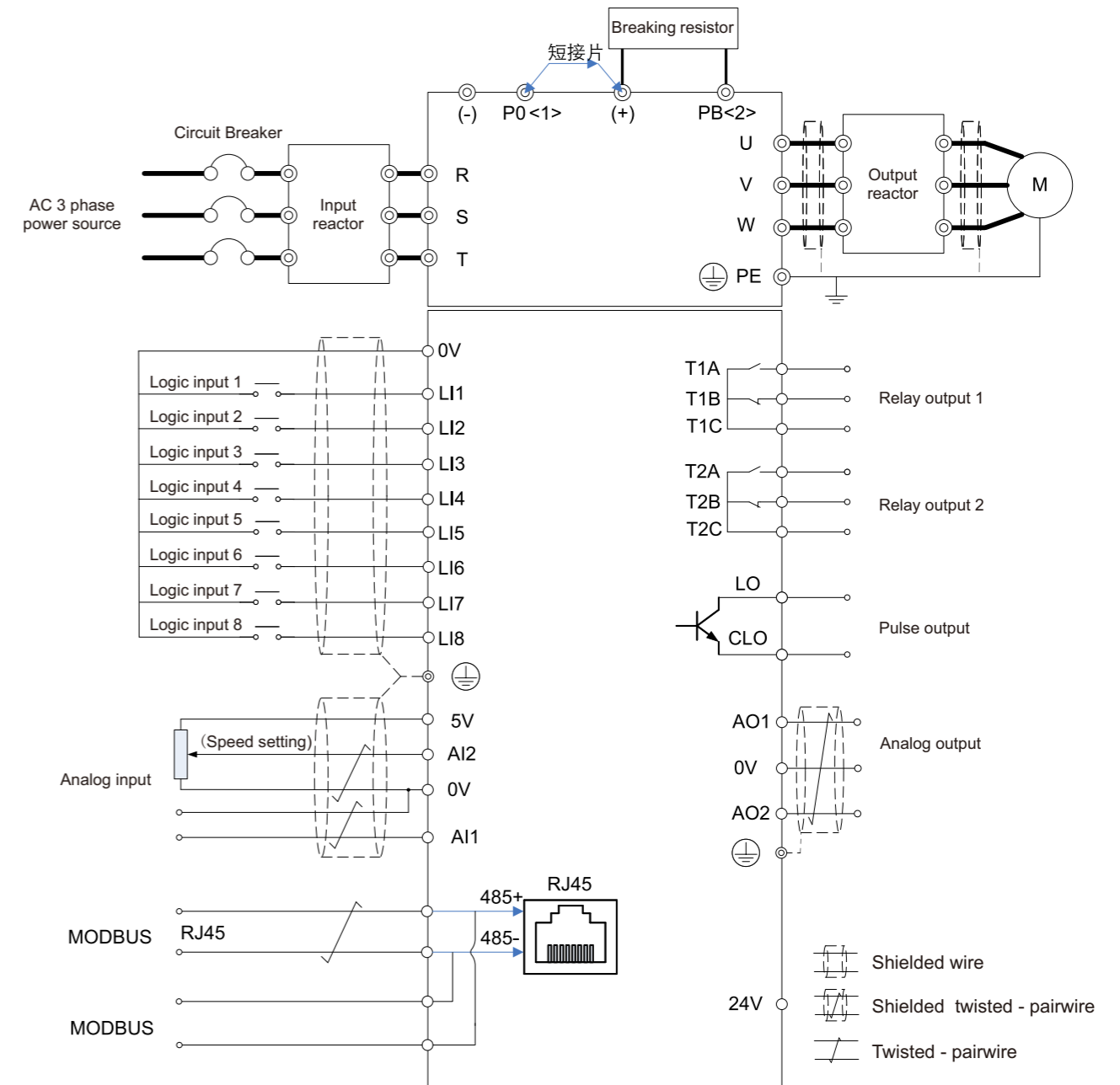

<1> 18.5-37kW VFD do not have P0 terminals. For inverters above 45kW (inclusive), be sure to remove the short-circuit between P0 and (+) when installing the DC reactor (optional).

<2> The 18.5-37kW VFD has a PB terminal, and a braking resistor can be connected between PB and (+).

Note: The figure shows the standard wiring diagram of RVE32 series 18.5kW (inclusive) and above. Please consult customer service for standard wiring diagrams of other power models.

■ Performance & configuration

Basic application functions	
Low frequency torque boost	The voltage boost and torque boost can increase the low-frequency torque of V/F control and speed sensorless vector control by about 0.1%~30.0% respectively.
V/F Curve	Linear type, multi-point type
Acceleration and deceleration curve	Linear or S-shaped acceleration and deceleration; three sets of acceleration and deceleration time; acceleration and deceleration time range: 0~3200s
Automatic Voltage Regulation (AVR)	When the grid voltage changes, it can automatically keep the output voltage constant
Built-in PID	Closed-loop control system that can easily realize process control
DC braking	DC braking range: 0.0Hz~maximum frequency; braking time: 0.0s~20.0s Braking action current value: 0%~100%
Jog control	The motor can be started and stopped immediately; the inching frequency setting range is: 0.0~20.0Hz Inching stop mode: deceleration/free/DC braking
Frequency Hopping	You can set 3 frequency hopping points and the corresponding frequency hopping range to prevent the drive from running within the frequency band.
Multi-speed	Up to 15 operating frequencies can be set via 4 logic input ports
Input Sum	The algebraic operation result of 2 analog inputs is used as the frequency setting, making the frequency setting more flexible
2 sets of motor parameter switching	Two sets of motor parameters can be set and switched freely to match the currently driven motor
Drive protection	Input/output phase loss protection, underload detection, over-torque protection, undervoltage protection, overvoltage protection, overcurrent protection, overheating protection, phase short circuit protection
Motor protection	Motor thermal protection, motor current limiting, motor overload, motor short circuit

Electrical characteristics	
Input voltage	Three-phase AC, 380~480V, 50/60Hz or single-phase AC, 200~240V, 50/60Hz
Output voltage	0~100% input voltage, 0.5Hz ~ 400Hz
Control Mode	Constant torque V/F, quadratic load V/F, sensorless vector control, energy-saving mode
On-off level	1.5kHz ~ 12kHz The automatic switching frequency adjustment function can be set: when the temperature rises, the switching frequency is automatically reduced After the temperature returns to normal, the switching frequency returns to the initial value
Overcurrent capability	150% rated output current for 60s, 200% rated output current for 2s

Control signal		
Frequency setting signal	Integrated operating panel	Membrane switch (button), speed knob (potentiometer)
	External Signal	UP/DOWN setting, analog input, multi-speed, external panel, serial communication
Start-stop control signal	Integrated operating panel	RUN, STOP buttons
	External Signal	Logic input terminal, external panel, serial communication

Control circuit characteristics			
Internal power supply available	24V	10VDC ±5%, maximum current 10mA, for reference potentiometer 24VDC ±5%, maximum current 100mA, for logic input port	
Analog Input	AI1	Voltage analog input: 0~5VDC, or 0~10VDC, impedance 30k Current analog input: 0/4~20mADC, impedance 250Ω Resolution: 10-bit A/D conversion Factory default setting: 0~5VDC voltage input	
	AI2	Voltage analog input: 0~10VDC, or PTC probe input Resolution: 10-bit A/D conversion	
Logic Input	LI1-LI8	0~24VDC power supply Positive logic (source), negative logic (sink) are optional, the factory default is negative logic 69 functions are available, including forward, reverse, running, fault reset, multi-speed, etc. Products below 15kW (inclusive) only have LI1-LI6	
	AI1, AI2 Enforce valid input	In inverters with 15kW or less, AI1 and AI2 can be set as logic inputs. F309 and F310 are mandatory valid inputs. Their configuration functions are always valid during power-on.	
Analog Output	AO1, AO2	Voltage analog output: 0~10VDC, minimum load impedance is 470Ω Current analog output: 0/4~20mA, maximum load impedance is 700Ω Resolution: 8 bits Output frequency, output current, speed setting, serial output data and other functions are optional	
Logic Output	LO, CLO	Open collector, maximum current 100mA, maximum voltage 30VDC Logic output or pulse output is optional, the factory default setting is logic output Output frequency, output current, speed setting and other output functions are optional	
Relay output	T1A, T1B, T1C T2A, T2B, T2C	T1A is normally open, T1B is normally closed, T1C is a common point T2A is normally open, T2B is normally closed, T2C is a common point Contact rating: 5A @ 250VAC, 5A @ 30VDC Fault, alarm, set frequency arrival and other functions are optional T1A defaults to failure, T2A defaults to operation	
Serial Communication		MODBUS-RTU, 2-wire RS-485, terminal interface	

Protective function	
Drive protection	Input phase loss protection, output phase loss protection, underload detection, over-torque protection, undervoltage protection, overvoltage protection, overcurrent protection, overheating protection, phase short circuit protection
Motor protection	Motor thermal protection, motor current limiting, motor overload, motor short circuit

Environmental characteristics			
Protection level	IP20	environment humidity	95% no condensation or water accumulation
Working temperature/storage temperature	-10~40℃ / -20~60℃	Altitude	Below 1000m
cooling method	Forced air cooling	Installation location	Indoor