

# RVE32 Series Variable Frequency Drive user's manual



Prior to use, please read this user's manual carefully.

CAUTION: Please keep this user's manual for future reference.

# **RVE32 series variable frequency drive**

User's Manual

V 24.12

# TABLE OF CONTENT

<b>1. PRELUDE .....</b>	<b>1</b>
1.1. Checking before use .....	1
<b>2. SAFETY REQUIREMENT AND CAUTIONS .....</b>	<b>2</b>
2.1. Warning signs and meanings .....	2
2.2. Safety operation .....	2
2.2.1 Machine checking .....	2
2.2.2 Mechanical installation .....	2
2.2.3 Electric installation .....	3
2.2.4 Precautions before power- on .....	3
2.2.5 Running .....	4
2.2.6 Maintenance and replacement of components .....	4
2.2.7 Scrap disposition .....	4
<b>3. TYPE AND SPECIFICATIONS .....</b>	<b>5</b>
3.1. Nameplate .....	5
3.2. Type of VFD .....	5
3.3. Basic performance and configuration .....	6
3.3.1 External installation dimensions .....	9
3.4. Care and maintenance .....	11
3.4.1 Daily inspection .....	11
3.4.2 Regular inspection .....	12
3.4.3 Replacement of wearing parts .....	12
3.4.4 Storage .....	12
3.5. Warranty .....	13
3.6. Scrapping .....	13
<b>4. INSTALLATION AND WIRING .....</b>	<b>14</b>
4.1. Mechanical Installation .....	14
4.1.1 Installation environment .....	14
4.1.2 Installation direction and spacing .....	14
4.1.3 Installation Method .....	15
4.1.4 Installation and removal of cover .....	16
4.2. Electrical wiring .....	17
4.2.1 Standard wiring diagram .....	17
4.2.2 Main circuit power terminals .....	19
4.3.1 Wiring of the control circuit .....	21
<b>5. BASIC OPERATION AND TRIAL RUNNING .....</b>	<b>24</b>
5.1. Appearance of keyboard panel .....	24
5.2. Basic operation of panel .....	25

5.2.1 Running model selection .....	25
5.2.2 Powering-on default mode .....	26
5.2.3.Parameter setting Mode .....	26
5.2.4 Status monitoring mode .....	27
5.2.5 Parameter verifying mode .....	28
5.2.6 JOG .....	28
5.3. Power on .....	28
5.3.1.Local control mode .....	29
5.3.2 Remote control mode .....	29
<b>6. DETAILED PARAMETER DESCRIPTION .....</b>	<b>34</b>
6.1. Basic parameter group .....	34
6.2. Motor and its protection parameter group .....	42
6.3. Motor control parameter group .....	45
6.4. Process PID parameter group .....	49
6.5. Fault protection parameter group .....	69
6.6. Fault protection parameter group .....	78
6.7. Keyboard panel parameter group .....	88
6.8. Additional function parameter group .....	94
6.9. Communication function parameter group .....	102
6.10. Process PID parameter group .....	105
6.11. Monitoring function parameter group .....	110
<b>7. FAULT DIAGNOSIS AND MEASURES .....</b>	<b>113</b>
7.1. Fault code, cause and measures .....	113
7.2. Description of alarm and indication code .....	116
7.3. Restart of the VFD after fault occurs .....	117
<b>8. APPENDIX A: SERIAL COMMUNICATION .....</b>	<b>118</b>
A1. RS-485 bus .....	118
A2. Modbus protocol .....	119
A2.1 Description of Modbus-RTU message format .....	119
A2.2 Detailed message description of different commands .....	120
A2.3 Cyclic redundancy check (CRC) .....	124
A2.4 Error code .....	124
A2.5 Communication parameter .....	125
<b>9. APPENDIX B: CONCISE PARAMETER LIST .....</b>	<b>130</b>
<b>10. APPENDIX C: BRAKE UNIT/RESISTANCE SELECTION .....</b>	<b>156</b>

# 1. PRELUDE

This User's Manual offers complete introduction of installation and use of the variable frequency drive, setting of function parameters, fault treatment and maintenance etc for VFD. Please read this manual carefully before using in order to guarantee correct installation and use of the VFD .

This manual is an accessory along with the machine. Please keep it properly for the future use for repair and maintenance.

## 1.1. Checking before use

When opening the box, please carefully check and confirm:

If the product inside together with the quality certificate, user's manual and warranty card;

Please check the "Model" column on the side of the machine, and re-confirm if the product and your order are consistent;

If there's any damage, scratch or dirt (damages caused during transportation are not within the company's warranty)

If there's any damage、 product missing or some other questions, please contact the dealer you purchased the product or the sales department of immediately.

Note: Do not install the frequency converter if you find the product is damaged or component missing, otherwise it may cause death or large safety incident.

## 2. SAFETY REQUIREMENT AND CAUTIONS

### 2.1. Warning signs and meanings

This manual has used the following signs which means there is an important parts of security. While observing against the rules, there is a danger of injury even death or machine system damage.



Danger: Wrong operation may cause serious injury or death



Wrong operation may cause death or large safety incident



Caution: Wrong operation may cause slight injury or damage to equipment.

Please read the user's manual carefully before installation, only professionally trained persons can be allowed to operate the equipment. "Professional trained persons" means the workers must be familiar with installation, wiring, running and maintenance. The operator must follow all the safety instructions to operate the machine.

If any physical injury or death or damage to the devices for ignoring to the safety precautions in the manual, our company will not be responsible for any damages and we are not legally bound in any manner.

### 2.2. Safety operation

#### 2.2.1 Machine checking



Do not install the frequency converter if you find the product is damaged or component missing, otherwise it may cause death or large safety incident.

#### 2.2.2 Mechanical installation



Please install the frequency converter on metal or fire-retardant material in case of fire.

Please keep the frequency converter away from combustible materials.

Do not install the frequency converter in the environment of explosive gas.



Please hold the bottom of the frequency converter when installing and transport to prevent the machine from falling.

The installation platform must be strong enough to hold the frequency converter in case the machine falling and lead to damage

Please install the frequency converter in the safe place with less vibration, avoid direct sunlight, no water splashing.

When installing two or more frequency converters in one cabinet, please ensure all the machines get good heat dissipation.

Take measures to avoid screws, cables and other conductive matters fall into the frequency converter during maintenance and component replacement.

### 2.2.3 Electric installation



#### **Danger**

Only professional electrical engineer was allowed to install the machine, otherwise there is a risk of electric shock.

There must be a circuit breaker between the frequency converter and input power, otherwise it may cause fire.

Before wiring, make sure the frequency converter is power-off, and all the charging indicator is completely extinguished, otherwise there is a risk of electric shock.

The PE terminal must be properly grounded in case of the risk of electric shock.



#### **Caution**

According to the power level of the frequency converter, please select the appropriate power cable for it, otherwise an accident may occur.

Don't connect the input power to the out terminals (U, V, W) of the frequency converter, otherwise it will cause damage to the drive system.

When connecting the output terminals (U, V, W), pay attention to the rotation direction of the motor.

Please make sure the connection and wiring meets the EMC requirement and the safety standards of the local area, otherwise an accident may occur.

Do not connect the braking resistor between the DC bus (+) and (-) terminals, otherwise it may cause fire.

Except control terminal T1A - T1B - T1C and T2A - T2B - T2C, all other terminals are forbidden to connect to the AC 220V signal. Otherwise it will cause damage to the frequency converter.

### 2.2.4 Precautions before power- on



#### **Danger**

Do not carry out any voltage-endurance test as all the products have past the test before leaving the factory.

Do not touch the driver and circuits with wet hands before and after power-on. Otherwise there is a risk of electric shock.

All covers must be installed and closed before powering on, otherwise there is a risk of electric shock.

Do not open the protective cover after power-on in case the risk of electric shock.

Do not touch any input and output terminals of the frequency converters after power-on, otherwise there is a danger of electric shock.



#### **Caution**

Before powering on, please confirm if the input voltage is consistent with the frequency converter's rated voltage, whether the wiring of the power input terminal(R,S,T) and output terminals(U,V,W) are correct, checking if there is short circuit for drive circuit.



The wiring of all accessories (like DC reactor, Braking resistor) must follow the instruction of this manual, otherwise it may cause an accident.

Do not change the parameters reserved by the manufacturer, otherwise it may cause damage to the equipment.

### 2.2.5 Running



#### **Danger**

Do not touch the cooling fan and discharge resistance to test the temperature when the machine is running, otherwise it may cause burn.

Only professional technician was allowed to detect frequency converter's signals during operation, otherwise it may cause personal injury or equipment damage.



#### **Caution**

During operation, metal or other debris should be prevented from falling into the equipment, otherwise the equipment may be damaged.

Do not use the contactor to start or stop the drive system of the frequency converter, otherwise it may cause equipment damage.

### 2.2.6 Maintenance and replacement of components



#### **Danger**

Only qualified electricians are allowed to perform the maintenance and must do the job according to the maintenance instruction.

The input power of the frequency converter must be cut off before maintenance. After at 10 minutes of discharge, the maintenance work can be carried out.

When plugged and unplugged the devices, make sure the power is off.

Take measures to avoid screws, cables and other conductive materials to fall into the frequency converter during maintenance and component replacement



#### **Caution**

Do not touch the components on the PCB board directly, static electricity is easy to damage the frequency converter.

After finish the work of repair, all the screws must be tightened.

When replacing the fan, pay attention to the rotation direction of the fan.

After replacing the control board, some parameter must be setting before the machine start again, otherwise there is damage to the equipment.

### 2.2.7 Scrap disposition



#### **Caution**

There are heavy metals in the frequency converter. Treat it as industrial effluent.

When the life cycle ends, the product should enter the recycling system. Dispose of it separately at an appropriate collection point instead of placing it in the normal waste stream.

## 3. TYPE AND SPECIFICATIONS

### 3.1. Model Description

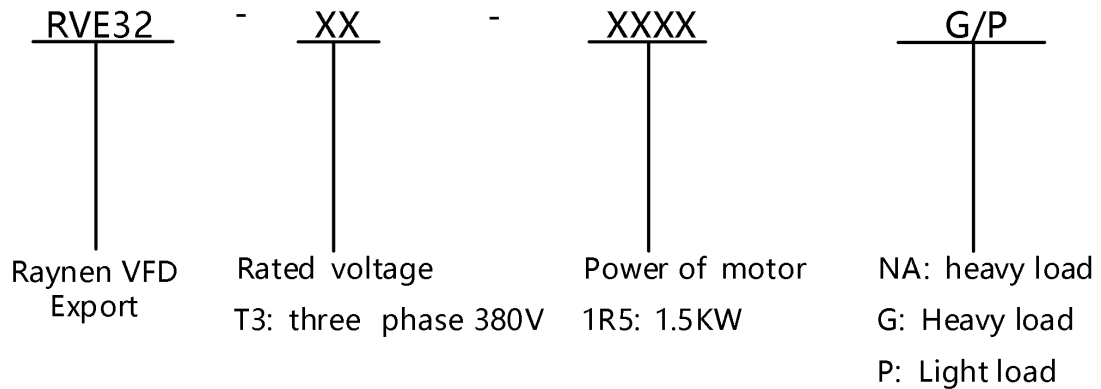

Figure 3.1 Schematic diagram of VFD model description

### 3.2. Type of VFD

Table 3.1 RVE32 series inverter specifications (three-phase 380V)

Model	G type machine (heavy load)			P type machine (light load)		
	Applicable motor (kW)	Rated input current (A)	Rated output current (A)	Applicable motor (kW)	Rated input current (A)	Rated output current (A)
RVE32-T3-0R7G/1R5P	0.75	3.6	2.6	1.5	6.4	4.1
RVE32-T3-1R5G/2R2P	1.5	6.4	4.1	2.2	8.7	5.5
RVE32-T3-2R2G/3P	2.2	8.7	5.5	3	10.9	6.9
RVE32-T3-3G/4P	3	10.9	6.9	4	14	9.5
RVE32-T3-4G/5R5P	4	14	9.5	5.5	20.7	12.6
RVE32-T3-5R5G/7R5P	5.5	20.7	12.6	7.5	26.5	18.5
RVE32-T3-7R5G/11P	7.5	26.5	18.5	11	36.6	25
RVE32-T3-11G/15P	11	36.6	25	15	40	32
RVE32-T3-15G/18P	15	40	32	18.5	47	38
RVE32-T3-18G/22P	18.5	47	38	22	56	45
RVE32-T3-22G/30P	22	56	45	30	70	60
RVE32-T3-30G/37P	30	70	60	37	80	75
RVE32-T3-37G/45P	37	80	75	45	94	92
RVE32-T3-45G/55P	45	94	92	55	128	115
RVE32-T3-55G/75P	55	128	115	75	160	150
RVE32-T3-75G/90P	75	160	150	90	190	180
RVE32-T3-90G/110P	90	190	180	110	225	215

Model	G type machine (heavy load)			P type machine (light load)		
	Applicable motor (kW)	Rated input current (A)	Rated output current (A)	Applicable motor (kW)	Rated input current (A)	Rated output current (A)
RVE32-T3-110G/132P	110	225	215	132	265	260
RVE32-T3-132G/160P	132	265	260	160	310	305
RVE32-T3-160G/185P	160	310	305	185	355	350
RVE32-T3-185G/200P	185	355	350	200	385	380
RVE32-T3-200G/220P	200	385	380	220	430	425
RVE32-T3-220G/250P	220	430	425	250	485	480
RVE32-T3-250G/280P	250	485	480	280	545	530
RVE32-T3-280G/315P	280	545	530	315	610	600
RVE32-T3-315G/355P	315	610	600	355	665	650
RVE32-T3-355G	355	665	650	-	-	-
RVE32-T3-400G	400	785	725	-	-	-
RVE32-T3-500G	500	890	860	-	-	-
RVE32-T3-560G	560	950	950	-	-	-
RVE32-T3-630G	630	1100	1100	-	-	-
RVE32-T3-710G	710	1280	1280	-	-	-
RVE32-T3-800G	800	1380	1380	-	-	-

Note: Products of 37kW and below are equipped with built-in brake units as standard, 45kW-185kW can be equipped with built-in brake units as optional, and 200kW-800kW can be equipped with external brake units as optional. When ordering, if you need to configure a brake unit, please make a note in the order.

### 3.3. Basic performance and configuration

Table 3.3 Basic performance and configuration

ITEM		SPECIFICATIONS
<b>Power input</b>	Rated voltage	T3: Three-phase 400V level: three-phase AC , (380-480)V
	Rated frequency	50/60Hz ± 5%
<b>Power Output</b>	The output voltage	0-100% input voltage
	Rated output current	Varies by model, see standard specifications for details
	Overload capacity	150% rated output current for 60s, 200 % rated output current for 2s
<b>Control performance</b>	control method	Constant torque V/f, quadratic load V/f, vector control without PG , energy-saving mode

ITEM		SPECIFICATIONS
	Frequency setting method	External terminals (including logic multi-speed, analog input, UP/DOWN setting , high-speed pulse input (partial power) ), keyboard panel, serial communication
	Command giving method	External terminals (i.e. logic inputs), keyboard panel, serial communications
	Frequency setting accuracy	Keyboard panel, UP/DOWN setting: 0.1Hz
		Analog setting, serial communication: 10bit (0.05Hz/50Hz)
	Low frequency torque	No PG V/f control: 150% rated torque/3Hz
		Vector control without PG: 150% rated torque/0.5Hz
	Speed control range	Without PGV/f control 1:40
		No PG vector control 1:200
	Speed control accuracy	Without PGV/f control $\pm 2\%$
Vector control without PG $\pm 0.2\%$		
Acceleration and deceleration time	0-3 2 00.0 seconds	
On-off level	1.5 kHz ~ 12kHz, can automatically reduce the switching frequency according to the junction temperature	
<b>Self-contained control power supply</b>	The output voltage	10 VDC $\pm 5\%$ (1 channel) 24VDC $\pm 20\%$ (1 channel)
	Maximum load	10V: Maximum current 10mA, used for reference potentiometer 24V: Maximum current 100mA, used for logic input port
<b>Analog Input</b>	quantity	2 channels: AI1, AI2
	type	DC voltage or DC current
	Maximum input range	AI1: 0-5VDC, or 0-10VDC, or 0/4-20mADC AI2: 0-10VDC, or PTC probe input
<b>Analog Output</b>	quantity	S2 AI1 & T3 -(0R4G -1R5G) : 1-way, AO1; T3 others : 2 channels , AO1 , AO2
	type	DC voltage or DC current
	Maximum output range	0-10VDC, or 0/4-20mADC
	Feature Selection	Output frequency, output current, speed setting, serial output data and other functions
<b>Logic Input</b>	LI1~LI8	S2 AI1 & T3-(0R4G -1R5G): LI1~LI6/P; T3 others : LI1~LI8; 0-24VDC power supply It has multiple functions such as forward, reverse, running, fault reset, multi-speed, etc.
	Enforce valid input	f309、 f310 It is a mandatory valid input, and its configuration function is always valid during power-on.
<b>Logic Output</b>	LO , CLO	Positive logic and negative logic are optional, the factory default is negative logic

ITEM		SPECIFICATIONS
		Logic output or pulse output is optional, the factory default setting is logic output
<b>Relay output</b>	TA , TB , TC T1A , T1B , T1C T2A, T2B, T2C	S2 All & T3-(0R4G -1R5G): TA, TB, TC; T3 others: T1A-T1B-T1C, T2A-T2B-T2C; T x A is normally open, T x B is normally closed, T x C is a common point Contact capacity: T x AT x C: 5A@250VAC , 5A@30VDC T x BT x C: 3A@250VAC , 3A@30VCD Function selection: fault, alarm, set frequency reaching and other functions.
<b>Communication Interface</b>	Hardware interface protocol	RS-485
	Software communication protocol	Modbus
<b>structure</b>	Protection level	IP20
	cooling method	Forced air cooling
<b>environment</b>	Installation location	indoor
	Operating temperature	-10 ~ 40°C
	Storage temperature	-20 ~ 60°C
	humidity	Below 95RH% (no condensation)
	Altitude	Below 1000m

### 3.4. Nameplate

Fujian Raynen Technology Co.,Ltd.	———— Company name
Model : RVE32-T3-5R5G/7R5P	———— VFD model
Max Appli Motor: 5.5kW/7.5kW	———— Max Motor Power
Input: AC3PH 380-480V 50/60Hz 20.7/26A	———— Input specification
Output: AC3PH 0-480V 0-400Hz 12.6/18.5A	———— Output specification
Operating Temperature: -10°C~40°C	———— Ambient temperature
IP Protection: IP20    Mass:	———— IP level/weight
S/N:	———— Ex-Factory Series NO.
	
TEL: 0591-88267288 ADD: No.26,ZoneC,Software Park, No.89 Software Avenue, Gulou District, Fuzhou	———— Hotline /Address

Figure 3.2 Nameplate example

### 3.3.1 External installation dimensions

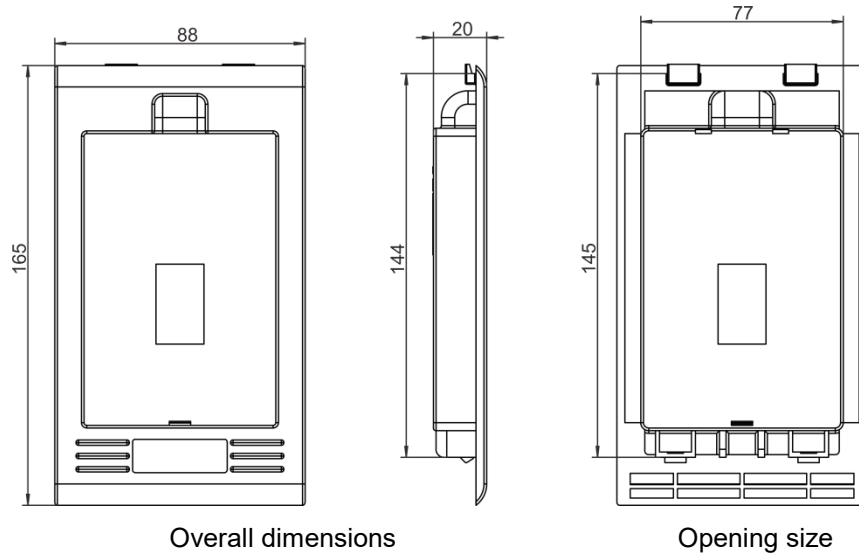

Figure 3.3 Operation panel dimensions

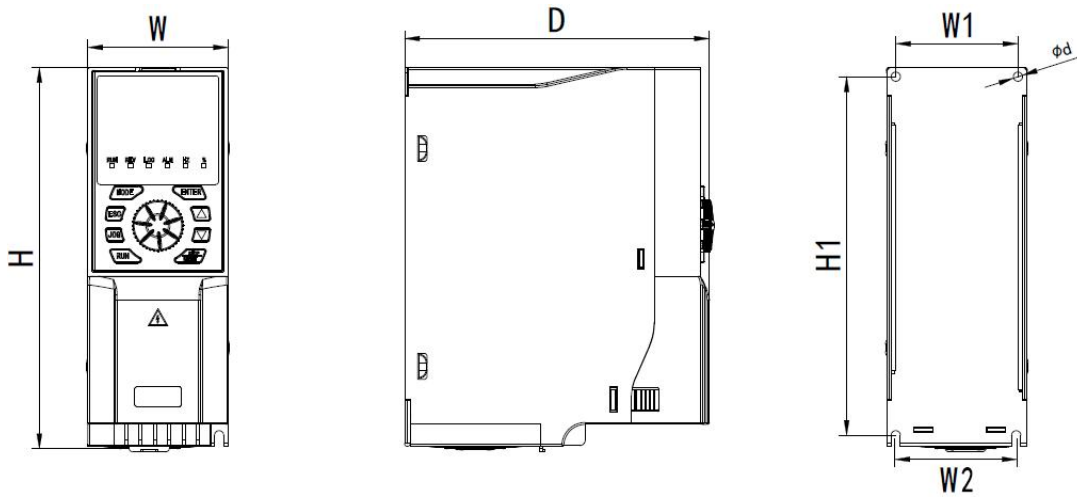

Figure 3.4 Appearance and installation dimensions (three-phase 15kW (inclusive) and below)

Table 3.4 Appearance and installation dimensions (three-phase 15kW (inclusive) and below)

Model	Outline Dimension (mm)			Installation Dimension (mm)			
	H	W	D	H1	W1	W2	Aperture
RVE32-T3-0R7G/1R5P	206	76.5	168.5	195	66.5	-	Φ5
RVE32-T3-1R5G/2R2P							
RVE32-T3-2R2G/3P							
RVE32-T3-3G/4P							
RVE32-T3-4G/5R5P	262	100	171	251	90	-	Φ5
RVE32-T3-5R5G/7R5P							
RVE32-T3-7R5G/11P							
RVE32-T3-11G/15P	353	120	222	341	108	90	Φ7
RVE32-T3-15G/18P							

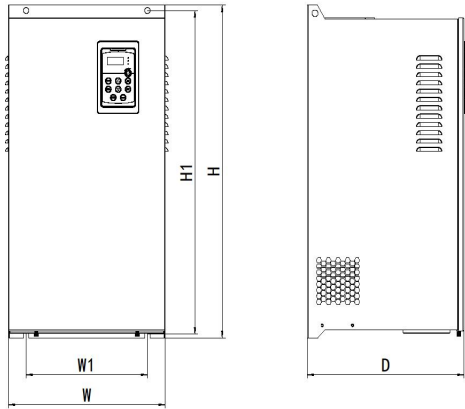

Figure 3.5 Appearance and installation dimensions  
(Three-phase including 18.5kW-315kW)

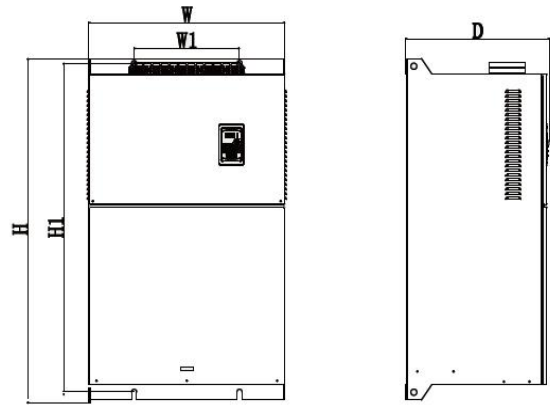

Figure 3.6 Appearance and installation dimensions  
(Three-phase including 355kW-500kW)

Table 3.5 Appearance and installation dimensions (three-phase including 18.5kW-500kW)

Model	Outline Dimension (mm)			Installation Dimension (mm)		
	H	W	D	H1	W1	Aperture
RVE32-T3-18G/22P	327	168	185.6	313	120	Φ9
RVE32-T3-22G/30P	335	200	195	321	140	Φ9
RVE32-T3-30G/37P	410	260	214	396	180	Φ9
RVE32-T3-37G/45P						
RVE32-T3-45G/55P	520	288	236	500	200	Φ11
RVE32-T3-55G/75P	560	305	300	543	200	Φ11
RVE32-T3-75G/90P	600	310	310	583	240	Φ11
RVE32-T3-90G/110P						
RVE32-T3-110G/132P						
RVE32-T3-132G/160P	720	355	345	698	240	Φ13
RVE32-T3-160G/185P						
RVE32-T3-185G/200P						
RVE32-T3-200G/220P	920	480	390	898	320	Φ13
RVE32-T3-220G/250P						
RVE32-T3-250G/280P	1100	480	405	1078	320	Φ13
RVE32-T3-280G/315P						
RVE32-T3-315G/355P						
RVE32-T3-355G	1100	650	465	1060	350	Φ17
RVE32-T3-400G						
RVE32-T3-500G						

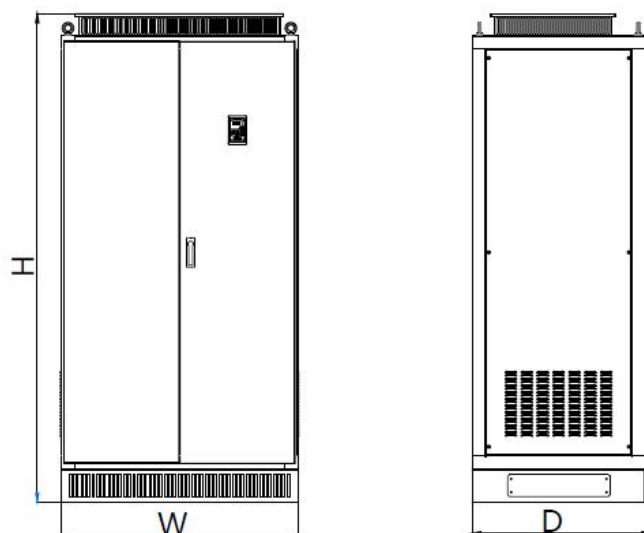

Figure 3.7 Appearance and installation dimensions (three-phase 560kW (inclusive) and above)

Table 3.6 (End) Dimensions (three-phase 560kW (inclusive) and above)

Model	Outline Dimension (mm)			Installation Dimension (mm)		
	H	W	D	H1	W1	Aperture
RVE32-T3-560G	2200	1100	800	943	665	Φ16
RVE32-T3-630G						
RVE32-T3-710G	2200	1400	800	1100	665	Φ16
RVE32-T3-800G						

### 3.5. Care and maintenance

Affected by ambient temperature, humidity, dust and vibration, the components inside the inverter will gradually age, causing inverter failure or reducing the service life of the inverter. Therefore, daily maintenance and regular maintenance of the inverter are required.

#### 3.5.1 Daily inspection

Table 3.7 Daily inspection items

Project	Content
temperature humidity	Confirm that the ambient temperature and humidity are within the specified range and there is no condensation;
Oil mist and dust	Confirm that there is no oil mist, dust, or condensed water inside the inverter;
Frequency Converter	Check whether the inverter has abnormal heating or vibration;
fan	Confirm that the fan is operating normally and there is no debris stuck;
Input Power	Confirm that the voltage and frequency of the input power supply are within the allowable range;
Motor	Check whether the motor has abnormal vibration, heating, abnormal noise, phase loss, etc.



### 3.5.2 Regular inspection

According to the actual working conditions, regular inspections should be carried out every 3 to 6 months, mainly including the following items:

Table 3.8 Regular inspection items

Project	Content
PCB, air duct	Is there any dust or dirt. If so, please use dry air to remove it.
Electrolytic Capacitors	Check for leakage, discoloration, or cracking. If so, replace the electrolytic capacitor.
cable	Check whether the surface of power cables and control cables is damaged, and whether the insulation tape has fallen off.
Control Terminals	Check if the screws are loose. If so, tighten them with a screwdriver.
Main circuit terminal	Is there any poor contact. Is there any overheating or arcing at the copper busbar connection.
Insulation test	After short-circuiting all input and output terminals of the main circuit, use a megohmmeter (DC 500V) to perform insulation test on the main circuit terminals to ground. The insulation resistance is required to be no less than 5 megohms. It is strictly forbidden to test a single terminal to ground, otherwise there is a risk of damaging the inverter.

### 3.5.3 Replacement of wearing parts

The fan in the inverter and the filter electrolytic capacitor of the main circuit are easily damaged parts. In order to ensure the long-term, safe and trouble-free operation of the inverter, the wearing parts should be replaced regularly. Usually, the replacement time of wearing parts is shown in Table 3.9.

Table 3.9 Reference life of wearing parts

Devices	Life
fan	30,000 to 40,000 hours
Electrolytic Capacitors	40,000 to 50,000 hours

As the working environment, load conditions and operating time change, the replacement time can be determined by yourself. The judgment criteria are shown in Table 3.10.

Table 3.10 Criteria for replacement of wearing parts

Devices	Cause of damage	Criteria
fan	Bearing wear and blade aging;	Check whether there are cracks on the fan blades, and whether there is abnormal vibration sound when the machine is turned on;
Electrolytic Capacitors	The ambient temperature is high; Electrolyte aging; Frequent load changes cause the pulsating current to increase.	Check whether there is any liquid leakage, whether the safety valve is protruding, measure the electrostatic capacitance, and measure the insulation resistance.

### 3.5.4 Storage

temporarily keeping or storing the inverter for a long time , pay attention to the following points:

- (1) Store in a dust-free , well-ventilated place within the specified temperature and humidity range.
- (2) power-on test must be performed every 6 months . When powered on, use a voltage regulator to slowly increase the input voltage to the rated value and run it for at least 5 hours with or without load.

### **3.6. Warranty**

- (1) The warranty scope only refers to the inverter body;
- (2) Under normal use, if a malfunction or damage occurs, the manufacturer will be responsible for a 12 -month warranty (from the date of manufacture). If it exceeds 12 months, a reasonable repair fee will be charged;
- (3) Within 12 months, if the following situations occur, a certain maintenance fee will be charged:
  - Failure to operate according to the instructions may cause damage to the machine;
  - Damage caused by fire, flood, abnormal voltage, etc.;
  - Damage caused by using the inverter for non-normal functions;
- (4) The relevant service fees will be calculated according to the manufacturer's unified standards. If there is a contract, the principle of contract priority will prevail.

### **3.7. Scrapping**

When scrapping the inverter, please dispose of it as industrial waste.

## 4. INSTALLATION AND WIRING

### 4.1. Mechanical Installation

#### 4.1.1 Installation environment

Table 4.1 Installation environment of the VFD

Environment	Condition
Installation location	indoor
Temperature	-10 °C ~ + 40 °C ; Avoid installing in places where the temperature changes rapidly; the temperature exceeds the allowable temperature , external forced heat dissipation or derating is required;
Humidity	≤ 95%RH, no condensation;
Altitude	1000m or less
Vibration resistance	≤ 5.9 m/s <sup>2</sup>
Other	Avoid installing in places with a lot of dust or metal powder; Avoid installing in places with corrosive or explosive gases and substances; Avoid places exposed to direct sunlight;

#### 4.1.2 Installation direction and spacing

In order to give full play to the heat dissipation effect of the inverter, it must be installed strictly in accordance with the specified direction and spacing.

(1) The inverter must be installed vertically and not upside down to facilitate heat dissipation upwards, as shown in Figure 4.1;

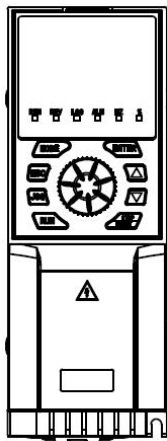

(A) Vertical installation  
(Correct installation method)

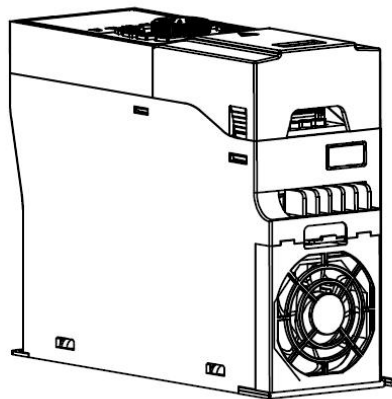

(B) Horizontal direction  
(Incorrect installation method)

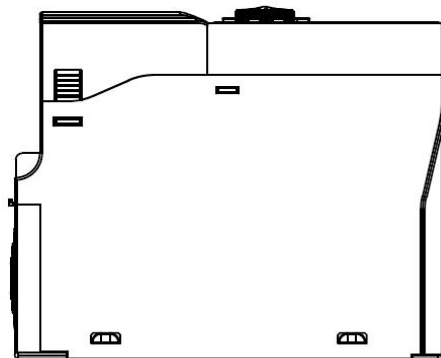

(C) Horizontal installation  
(Incorrect installation method)

Figure 4.1 Installation direction diagram

(2) When installing a single unit, the installation spacing requirements are as shown in Figure 4.2;

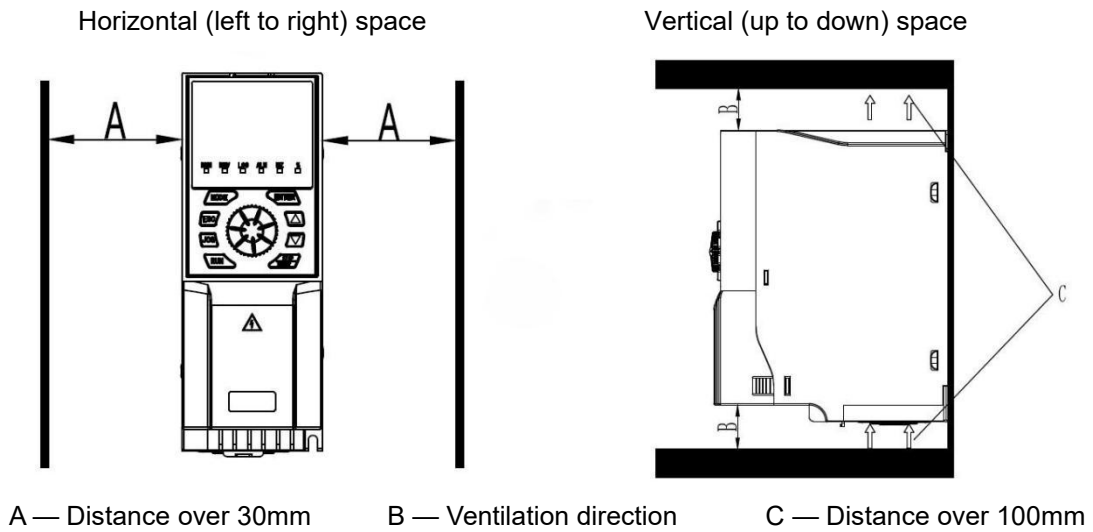

Figure 4.2 Single installation spacing requirements

(3) When multiple units are installed, they are usually installed side by side. The installation spacing requirements are shown in Figure 4.3;

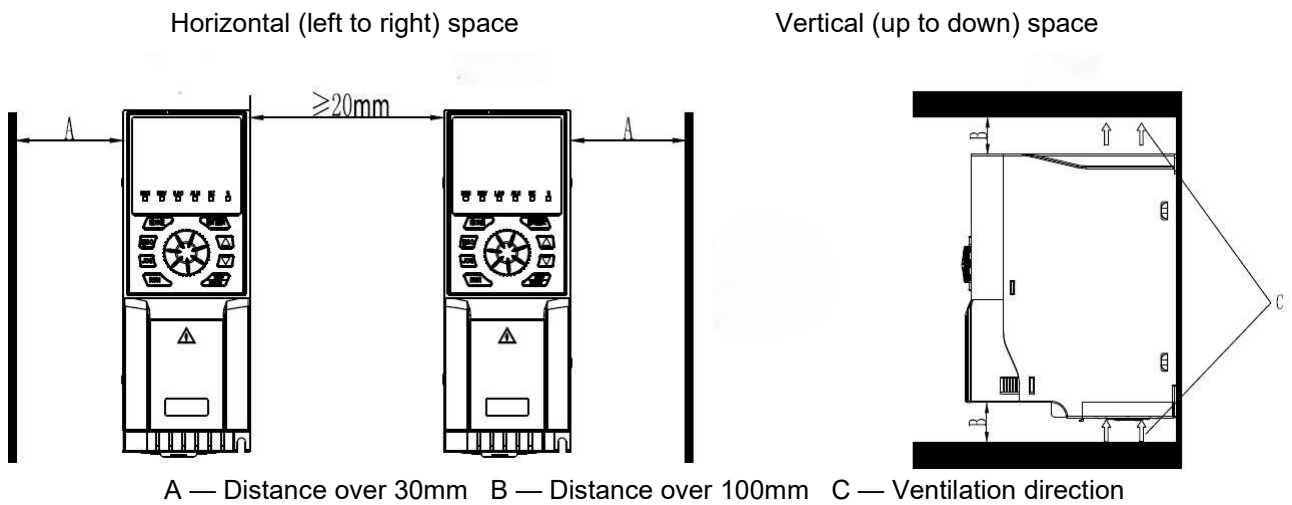

Figure 4.3 Spacing requirements for multiple installations

(4) When multiple units are installed up and down, guide baffles should be added between them to ensure the heat dissipation effect.

### 4.1.3 Installation Method

- (1) Determine the position of each screw hole;
- (2) Install the lower screws, but do not tighten them completely, leaving an appropriate gap ;
- (3) Insert the U-shaped hole at the bottom of the inverter into the screw installed in (2);
- (4) Install the upper screws, being careful not to tighten them completely, leaving an appropriate gap;
- (5) Tighten each screw in turn until they are fully tightened.

#### 4.1.4 Installation and removal of cover

Installation and removal of cover plates and outlet plates below 15kW (inclusive): Remove the cover plate fastening screws, hold the middle of the vertical surface of the right step of the cover plate with your thumb, push to the left, and then lift it up to remove the cover plate; then remove the outlet plate as shown in Figure 4.4 and install the cable.

After the wiring is completed, install the outlet plate first and then the cover plate, and finally tighten the screws.

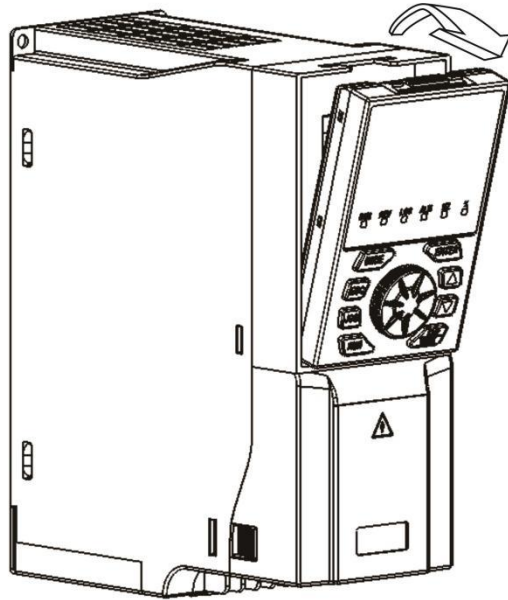

Figure 4.4 Diagram of disassembly of control panel

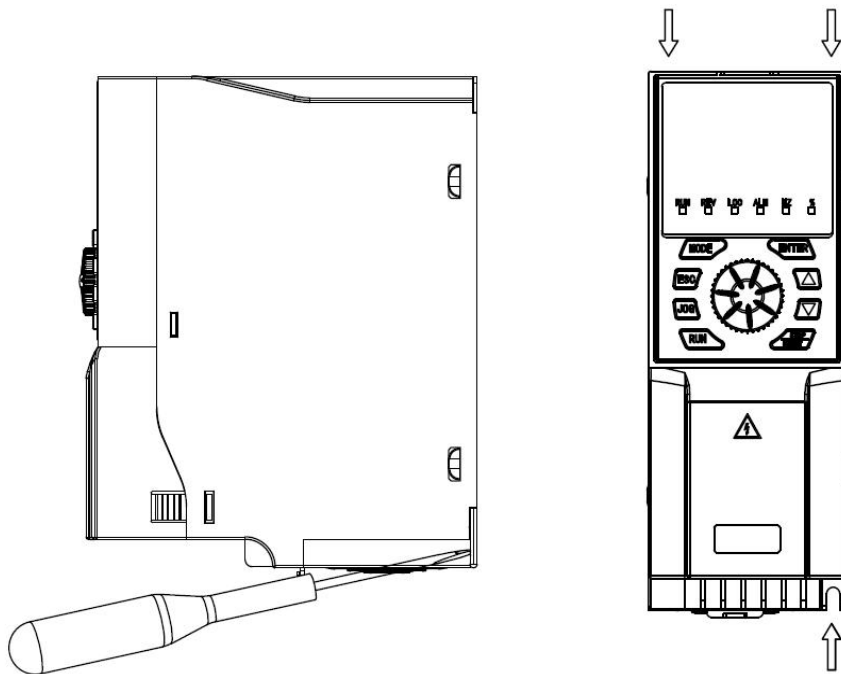
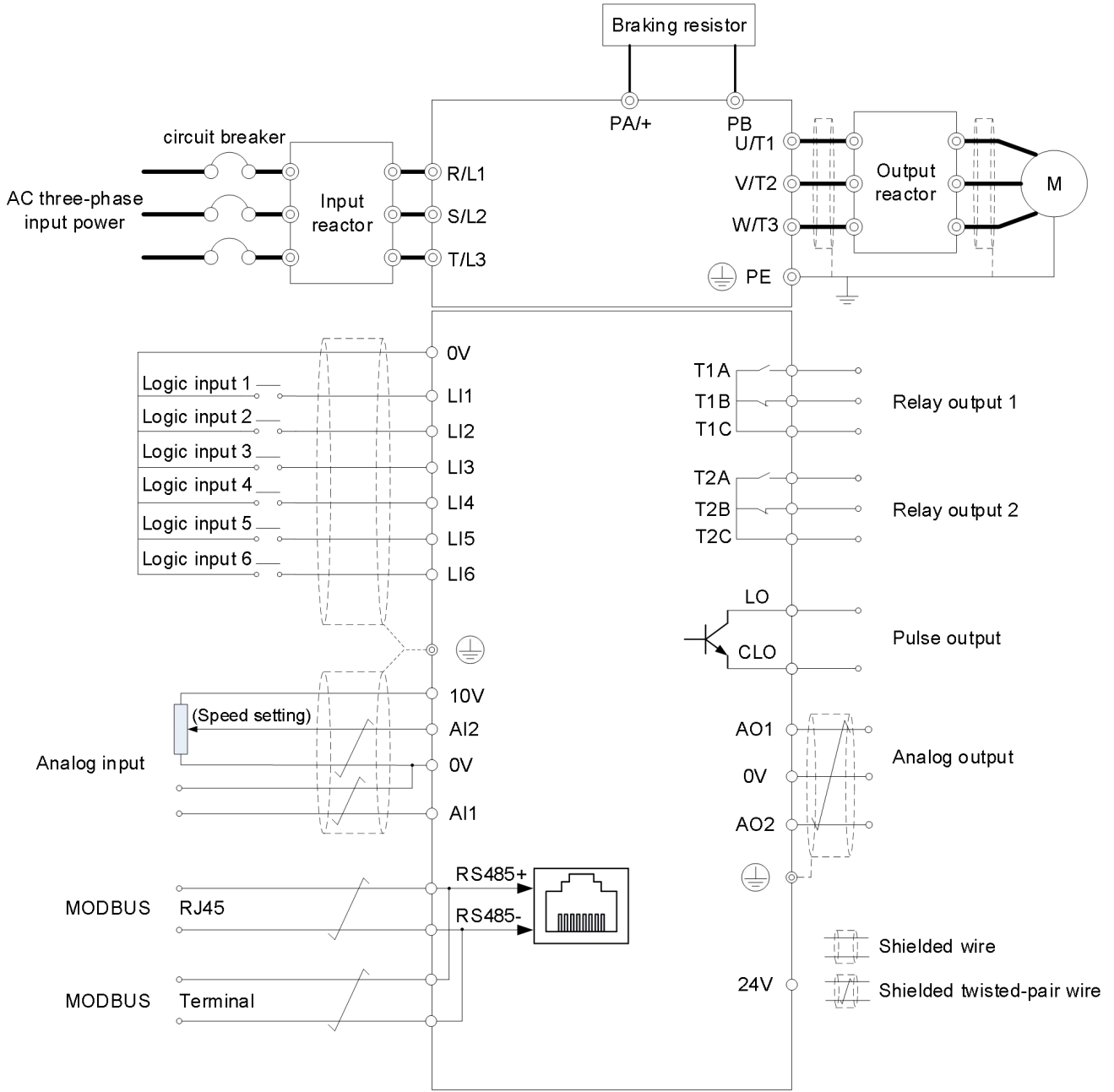

Figure 4.5 Diagram of disassembly of cover plate and outlet board

## 4.2. Electrical wiring

### 4.2.1 Standard wiring diagram



(a) Standard wiring diagram for 15kW (inclusive) and below

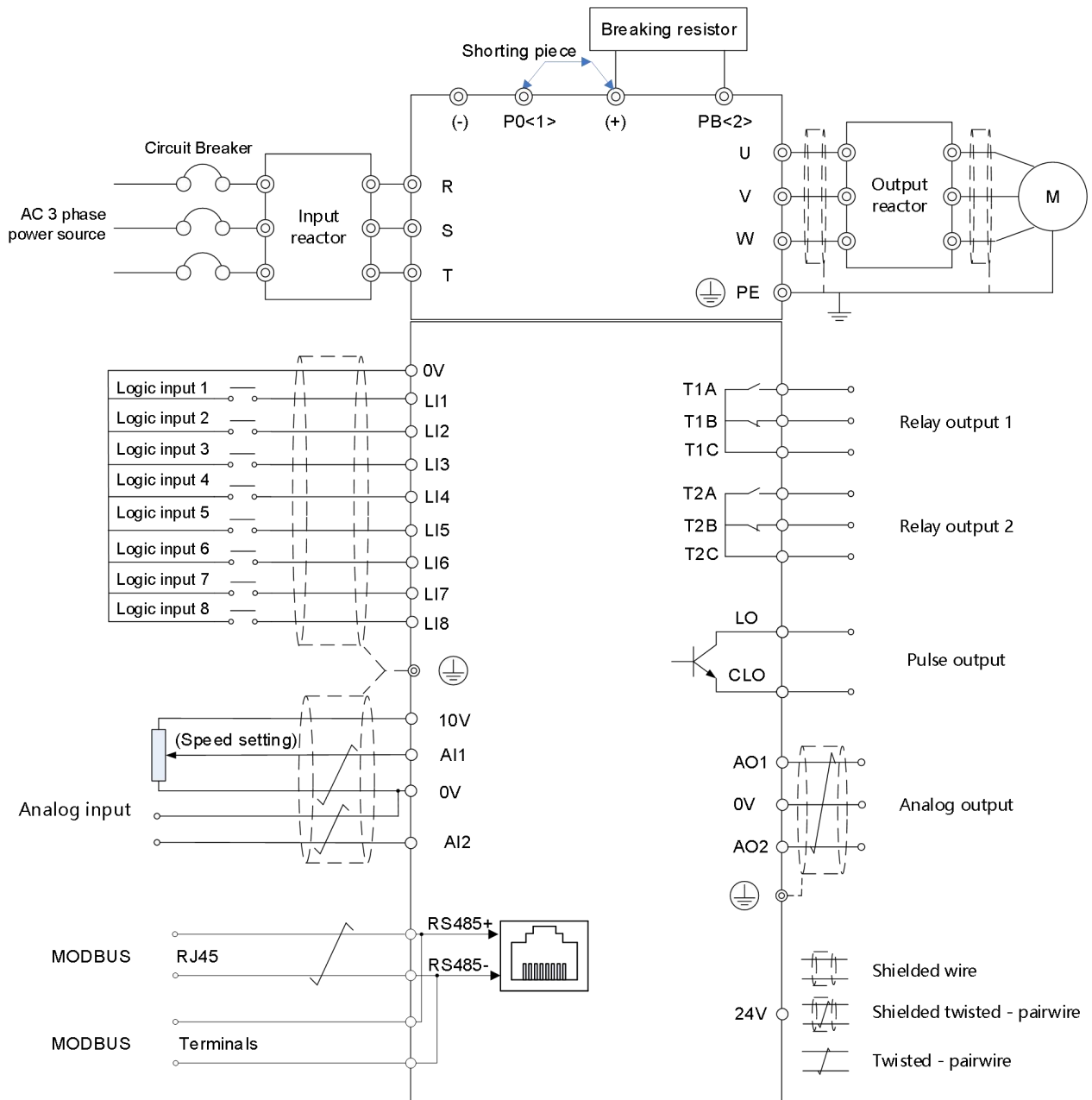

<1> 18.5-37kW inverters do not have P0 terminals; for inverters above 45kW (inclusive), be sure to remove the short-circuit between P0 and (+) when installing the DC reactor (optional).

<2> 18.5-37kW inverters have PB terminals, and a brake resistor can be connected between PB and (+).

(b) Standard wiring diagram for inverters above 18.5kW (inclusive)

Figure 4.6 Standard wiring diagram for operation

## 4.2.2 Main circuit power terminals

The structure of the product's main circuit power terminals is shown in Figure 4.7, and the functional description is shown in Table 4.2.

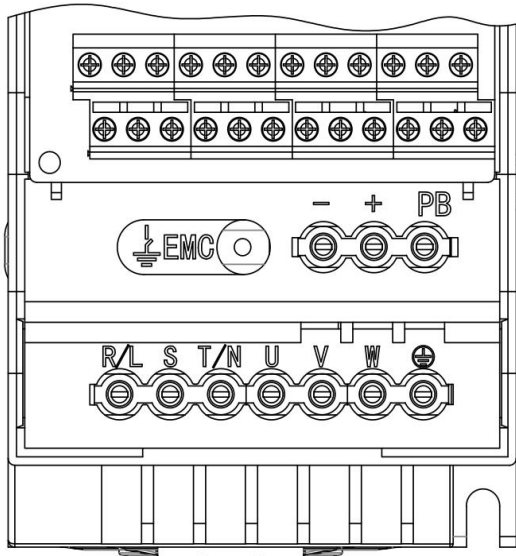

(a) Main circuit power terminal (0.75-2.2kW)

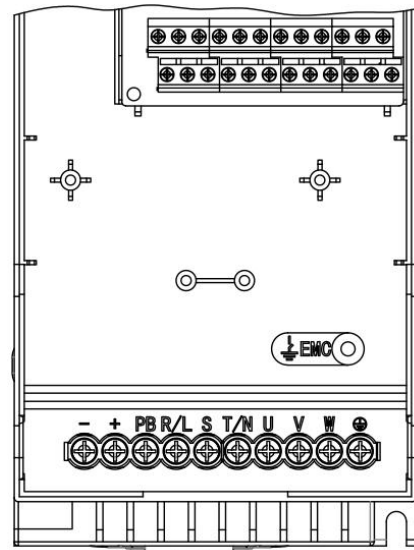

(b) Main circuit power terminal (4-7.5kW)

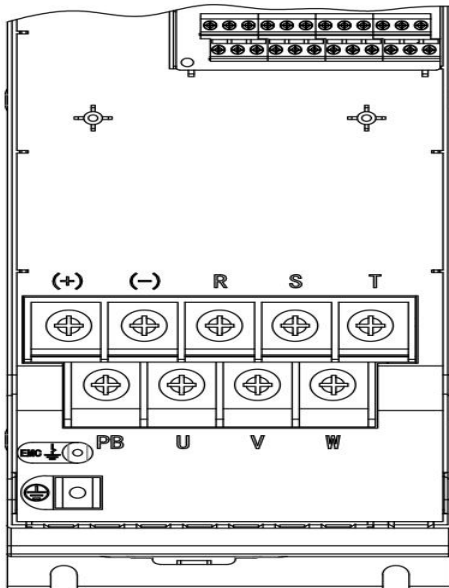

(c) Main circuit power terminal (11-15kW)

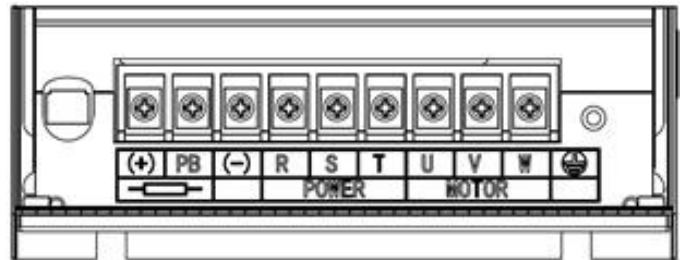

(d) Main circuit power terminal (18.5-22kW)

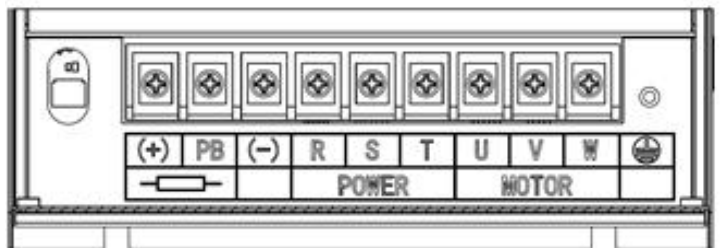

(e) Main circuit power terminal (30-37kW)

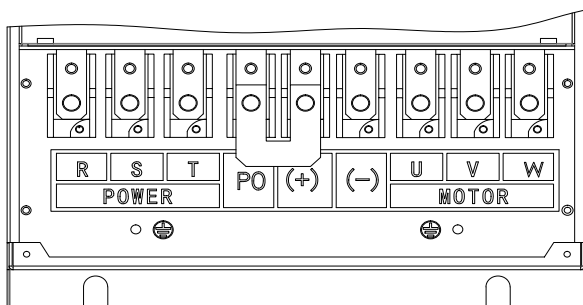

(f) Main circuit power terminal (45kW)

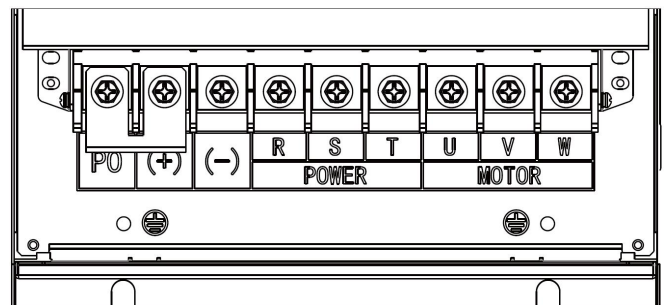

(g) Main circuit power terminal (55kW)



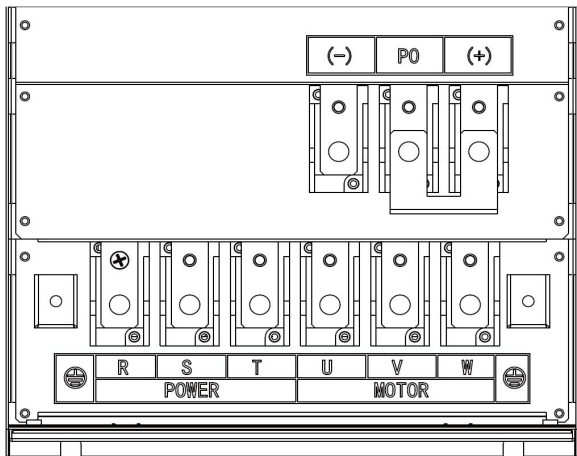

(h) Main circuit power terminal (75-100kW)

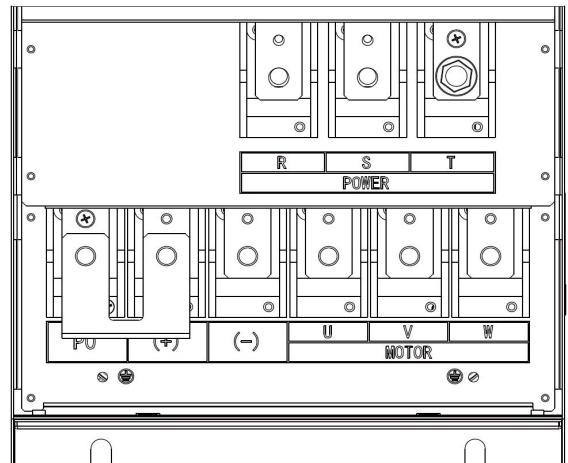

(i) Main circuit power terminal (132-185kW)

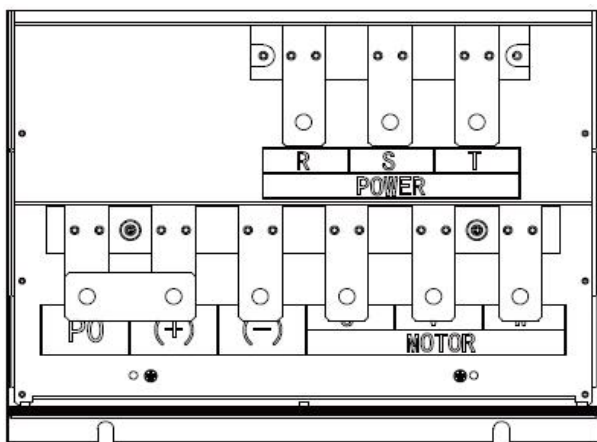

(j) Main circuit power terminal (200-220kW)

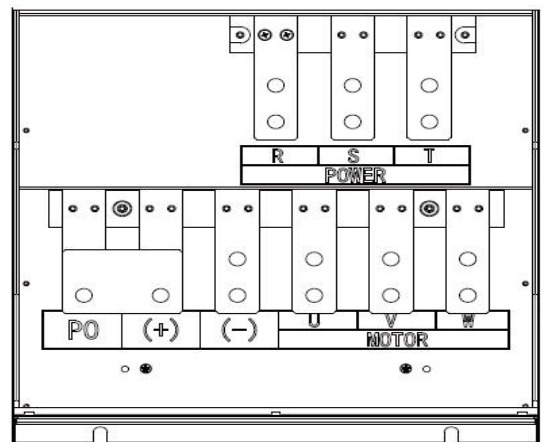

(k) Main circuit power terminal (250-315kW)

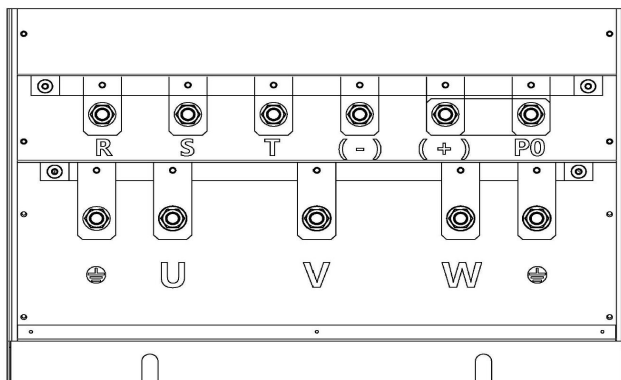

(l) Main circuit power terminal (355-500kW)

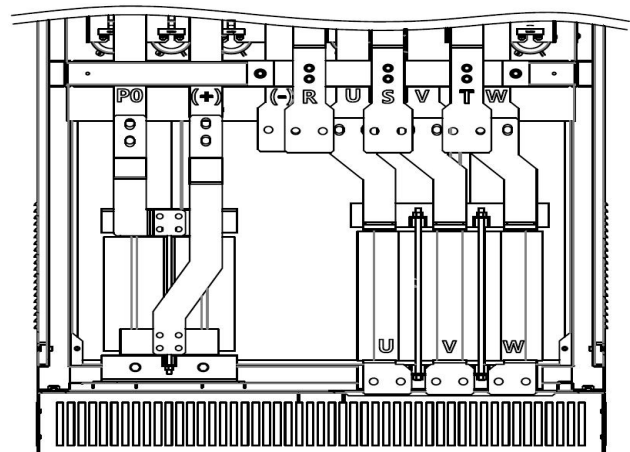

(m) Main circuit power terminal (560-800kW)

Figure 4.7 Diagram of the main circuit terminals of the VFD

Table 4.2 Description of main circuit terminals

Symbol	Function
R/L1、S/L2、T/L3	Three-phase AC power input terminal, connect to three-phase AC power: 380V, 50 Hz /60Hz
U/T1、V/T2、W/T3	The inverter output terminal is connected to the three-phase induction motor
+、-	DC bus connection terminal, external brake unit, etc. (+)——DC bus positive pole, (-)——DC bus negative pole
PA/+、PB +、PB	Braking resistor connection terminal, connect the braking resistor PA/+, + —— DC bus positive pole
P0、+	DC reactor connection terminal, external DC reactor
	Grounding terminal, connected to the protective ground. The grounding resistance cannot be greater than 4 Ω at 400V level.

### 4.2.3 Wiring of the control circuit

The control terminal structure is shown in Figure 4.8 and the functional description is shown in Table 4.3.

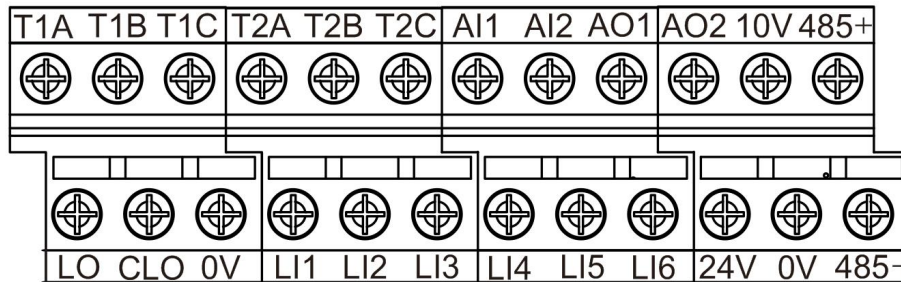

(a) Control terminals (15kW and below)

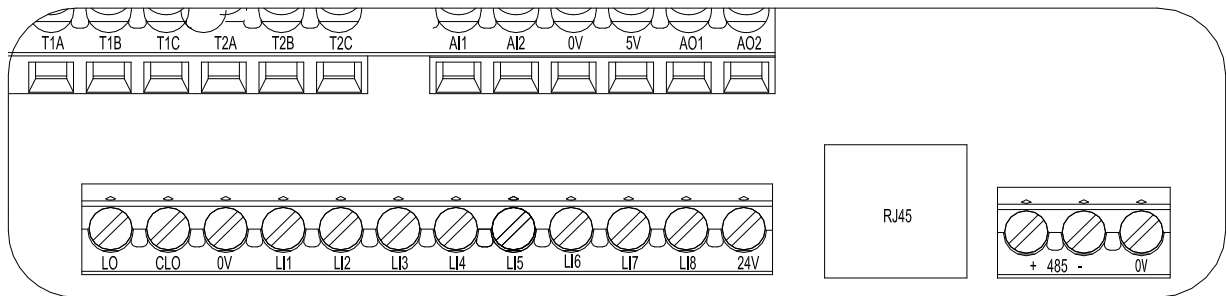

(b) Control terminals (18.5kW and above)

Figure 4.8 Control terminal structure diagram

Table 4.3 Description of Control terminals function

Symbol	Item	Function
0V		public terminal of the control circuit
5V/10V	5V/10V output voltage	15kW (inclusive) and below: 10V; 18.5kW (inclusive) and above 5V is generally used as the working power supply of the external potentiometer; Maximum current: 10mA Accuracy: $\pm 5\%$
24V	24V output voltage	Generally used as the working power supply for logic input terminals; Maximum current: 100mA Accuracy: $\pm 20\%$

Symbol	Item	Function
AI1	Voltage/current analog input or programmable logic input	Voltage or current analog input: Resolution: 10 bits Analog voltage input: 0 ~ +5 V or 0 ~ +10 V, input impedance 30k; Analog current input: maximum 20 mA, input impedance 250 Ω .
		By changing the parameter settings, AI1 can also be used as a programmable logic input terminal. When used as a logic input, a resistor (4.7k Ω ~10 k Ω , 1/2W) must be added between 24V-AI1, as shown in Figure 4.9; at the same time, AI1 is set to 10V analog voltage input.
AI2	Voltage Analog input Or programmable logic input	Voltage analog input: Resolution: 10 bits Maximum range: 0 ~ +10 V, input impedance 30k
		By changing the parameter settings, AI2 can also be used as a programmable logic input terminal. When used as a logic input, a resistor (4.7k Ω ~10 k Ω , 1/2W) must be added between 24V-AI2. The wiring method refers to AI1.
LI1 to LI8 (including LI6/P)	programmable logic input	+24 V power supply
		Positive logic ( source): Port voltage is < 5 V, the input is invalid (OFF). Port voltage is > 11 V, the input is valid (ON).
		Negative logic (sink): Port voltage > 16 V, the input is invalid (OFF). Port voltage is < 10 V, the input is valid (ON).
		Figure 4.10 for the logic input connection diagram .
	LI6 /P can be configured as high-speed pulse input, frequency range: 0.00kHz~20kHz	
AO1 AO2	Voltage/current analog output	Analog voltage output: 0 ~ +10 V, minimum load impedance is 470 Ω ; Analog current output: x ~ 20 mA, maximum load impedance is 700 Ω ;
LO	Pulse output collector	Maximum current:100mA
CLO	Pulse output emitter	Maximum voltage:30V
T1A	Relay 1 Normally Open Contact	Maximum switching capacity : T1A-T1C: 5A @ 250VAC, 5A @ 30VDC T1B-T1C: 3A @ 250VAC, 3A @ 30VDC
T1B	Relay 1 Normally Closed Contact	
T1C	Relay 1 common contact	
T2A	Relay 2 Normally Open Contact	Maximum switching capacity : T2A-T2C: 5A @ 250VAC, 5A @ 30VDC T2B-T2C: 3A @ 250VAC, 3A @ 30VDC
T2B	Relay 2 Normally Closed Contact	
T2C	Relay 2 common contact	

Symbol	Item	Function
T5	RS485 communication port	4nd feet is positive port of RS485 differential signa, 5nd feet is the negative port of RS485 difference signal.
SW700	RS485 impedance matching	SW700 is only for inverters above 18.5kW (inclusive). SW700 has 3 switches, from left to right: SW700-1: ON — connect the pull-up resistor of RS485+ signal; SW700-2: ON — connect the pull-down resistor of RS485- signal; SW700-3: ON — connect the matching resistor between RS485+ 、 - signals.

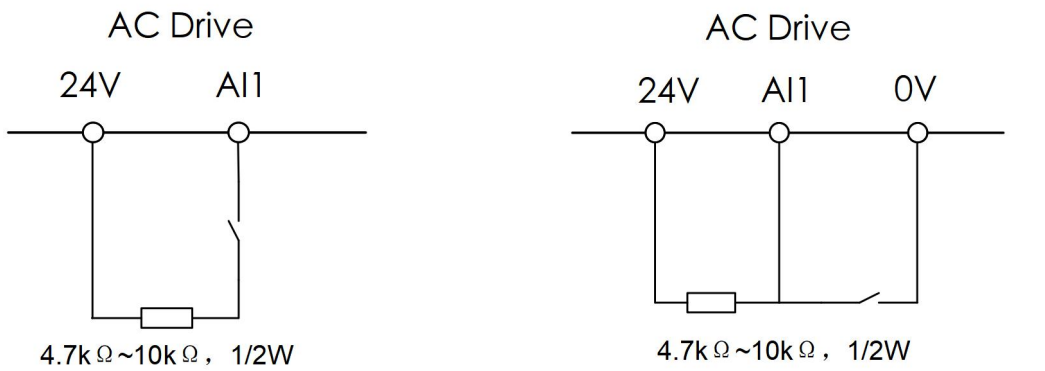

(a) Positive Logic – source

(b) Negative Logic – sink

Figure 4.8 Wiring diagram when AI1 is configured as a logic input terminal

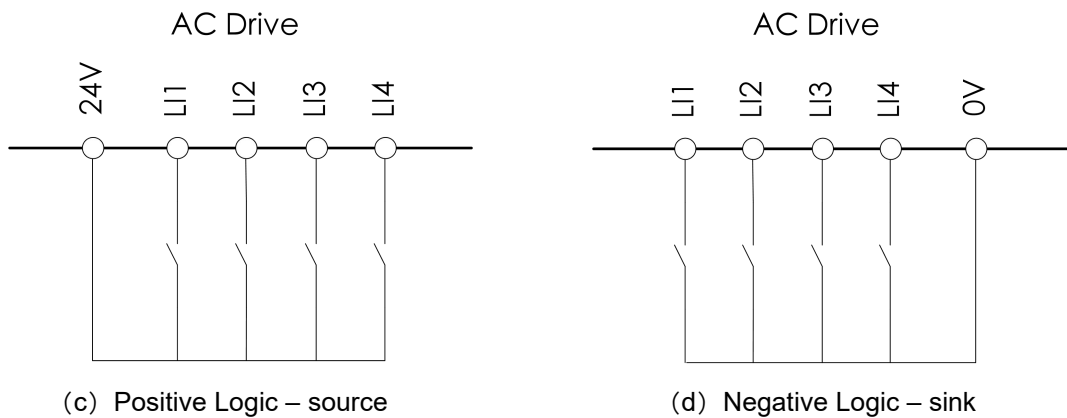

(c) Positive Logic – source

(d) Negative Logic – sink

Figure 4.9 Logic input terminal wiring diagram

## 5. BASIC OPERATION AND TRIAL RUNNING

### 5.1. Appearance of keyboard panel

The operation panel is the human-machine interactive interface of the inverter. Through the operation panel, the user can modify the function parameters, control the operation (start, stop) and monitor the working status of the inverter. For its appearance and functions, please refer to Figure 5.1 and Table 5.1.

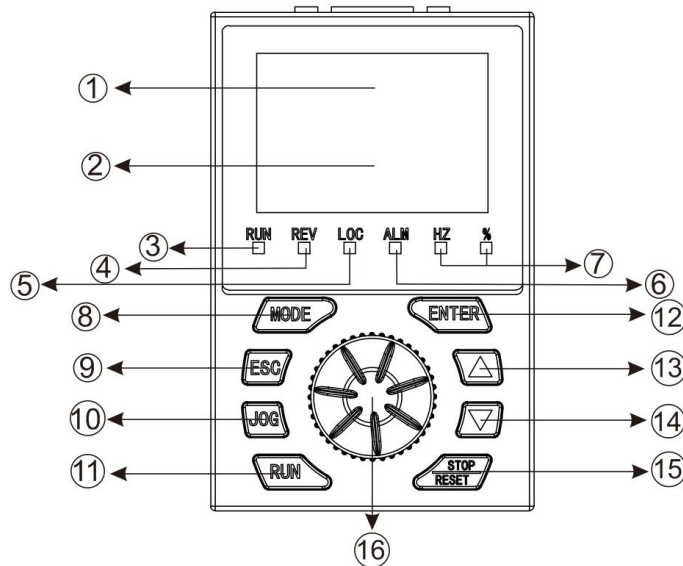

Figure 5.1 Operation panel appearance

Table 5.1 Names and functions of the various parts of the operation panel

NO.	Designation	Sign	Functional performance
1	Display area 1	—	LED digital display for showing function parameters and set values, etc.
2	Display area 2	—	LED digital display for monitoring values.
3	Running status indicator	RUN	On: The operation command and frequency setting are valid, and the output of the VFD is normal; Flash: The running command is valid, but the frequency setting is invalid. The VFD has no output; Off: Currently no running command, no output of the VFD, in standby state.
4	Reverse status indicator light	REV	On: Reverse Off: Forward
5	Local status indicator	LOC	On: Local Off: Remote
6	Failure status indicator	ALM	On: Failure Off: No failure
7	Unit light	%	The current display data is a percentage.
		Hz	The unit of data currently displayed is Hz.

NO.	Designation	Sign	Functional performance
8	Mode	MODE	Select the operating mode of the VFD or go back to mode from the sub-menu.
9	Escape)	ESC	Exits the current state and returns to the previous state.
10	Jog reset	JOG	Default is shortcut menu 3. See parameter f700 for Settings.
11	Run	RUN	Turn on VFD output.
12	Enter	ENTER	Enter mode, view parameters, or confirm set values.
13	Up	▲	Add parameter number and parameter setting value.
14	Down	▼	Reduce parameter number and parameter setting value.
15	Stop/reset	STOP/ RESET	Stop the output of the converter and change to the reset button when fault is detected.
16	Speed control knob	—	Adjust the speed.

## 5.2. Basic operation of panel

### 5.2.1 Running model selection

Variable Frequency Drive include four running models: Powering-on default mode、Parameter setting mode、Status monitoring mode and Parameter verifying mode. Any mode can be realized by the MODE Key, showed as Figure 5.2:

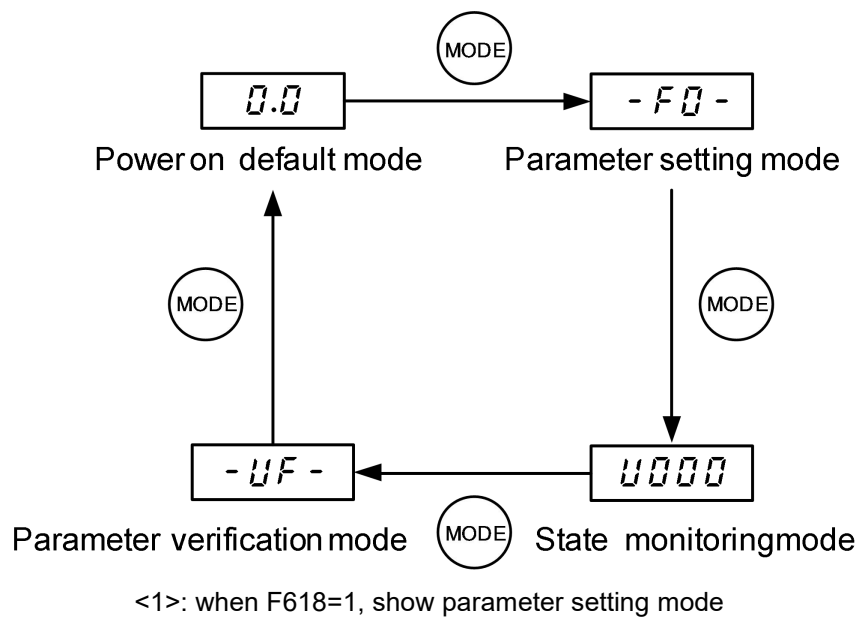

Figure 5.2 Structure of VFD Mode switch

### 5.2.2 Powering-on default mode

The displayed data in the power-on default mode is the current output frequency. You can directly use ▲ or ▼ to modify the digital frequency setting, and then press the ENT key to save the modified data and return to the power-on default mode, or press the ESC key to abandon the modification and return to the power-on default mode, as shown in Figure 5.3.

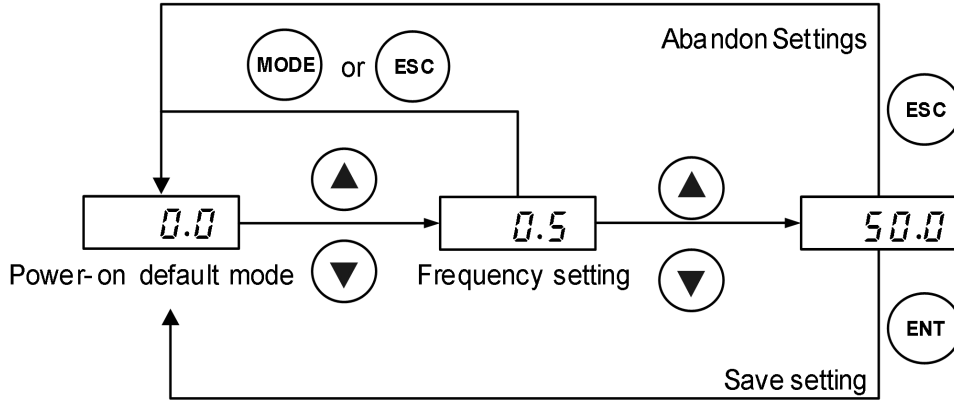

Figure 5.3 Power-on default mode navigation

Type in the power-on default mode can be freely set, see parameter f610 for details.

### 5.2.3. Parameter setting Mode

10 groups of function parameters in parameter setting mode, namely group f0, group f1 ... group f9. Each group contains different numbers of function parameters. The set value of each parameter can be modified by ▲, ▼ and ENT keys, or the modification can be abandoned by ESC key, as shown in Figure 5.4.

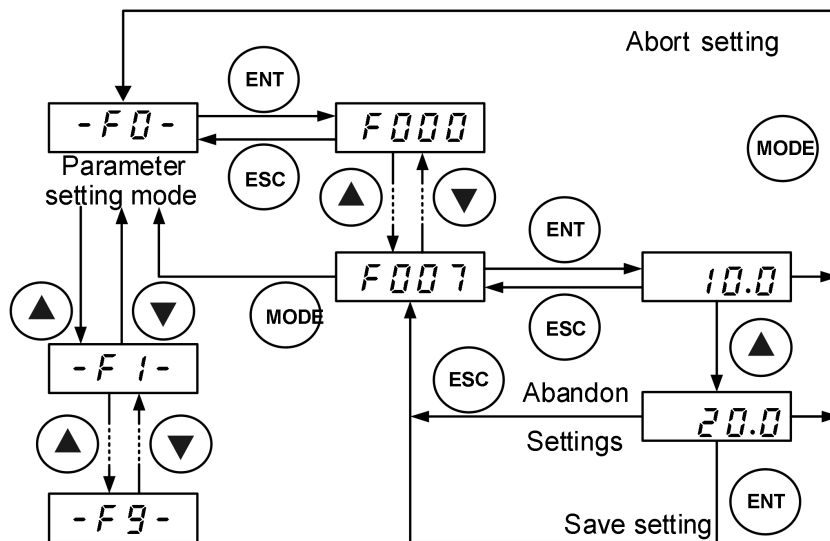
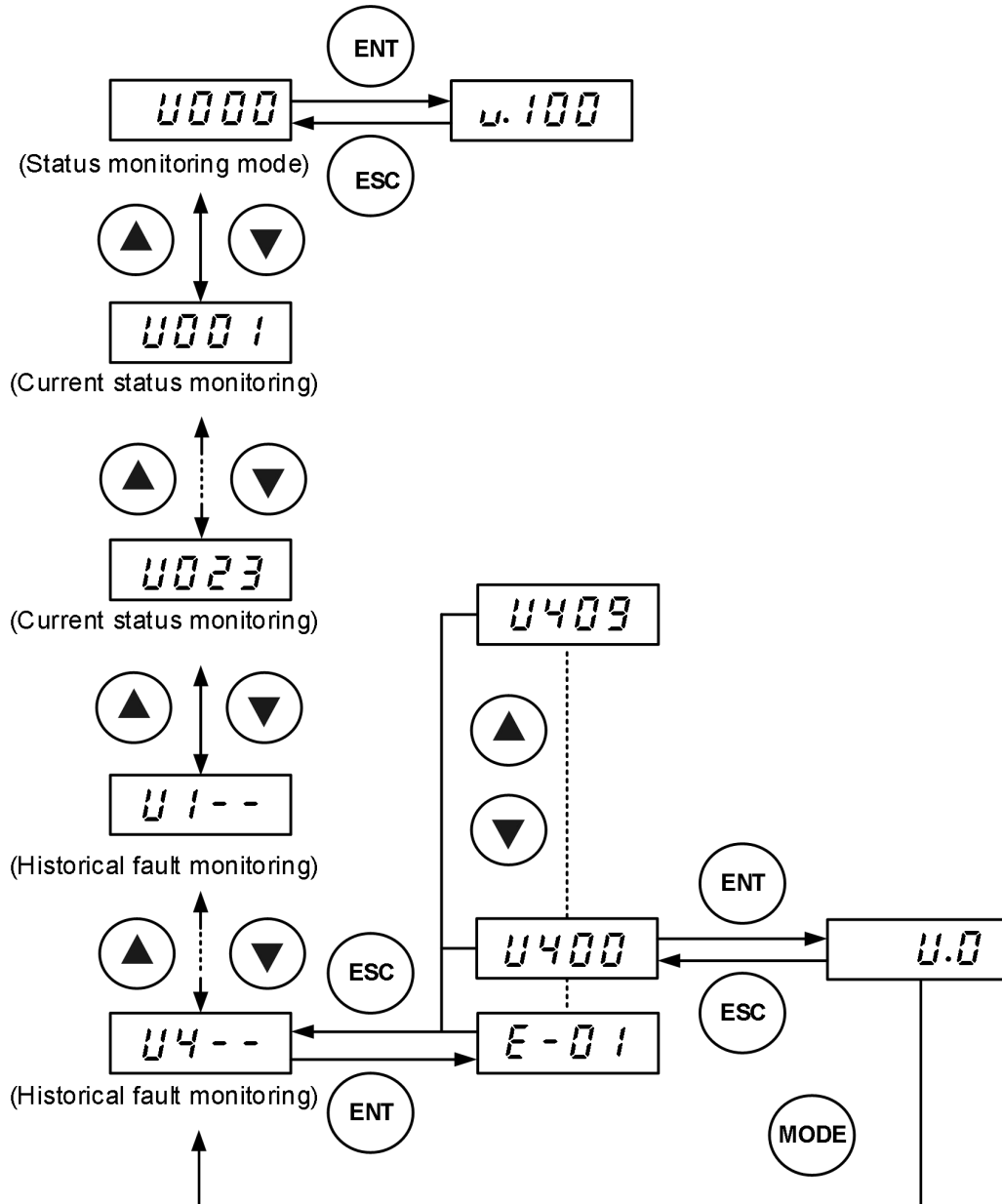

Figure 5.4 Parameter Setting Mode navigation

### 5.2.4 Status monitoring mode

The status monitoring mode is mainly used to monitor the current operating status of the inverter or view fault history records. The specific operation is shown in Figure 5.5.



Note: Monitoring parameters can only be viewed, not modified or set.

Figure 5.5 Status monitoring mode navigation



### 5.2.5 Parameter verifying mode

When f618 = 1 , press the MODE key to switch to parameter calibration mode.

In parameter verification mode, you can see all parameters that are different from the factory default settings. The setting methods of these parameters are the same as in parameter setting mode, as shown in Figure 5.6.

Note: When no parameters are changed, "-uf-" will not be displayed after pressing the ENT key.

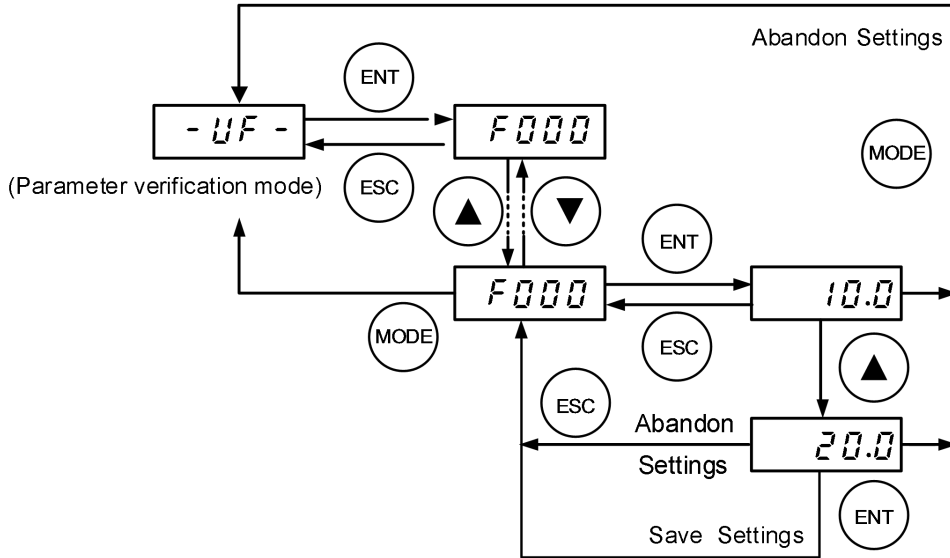

Figure 5.6 Parameter verifying mode navigation

### 5.2.6 JOG

In power-on mode, when f700=1, press the JOG key to enter the jog state directly.

After entering the jog state, the displayed data changes to JOG or -JOG, indicating forward jog and reverse jog respectively. In local mode, the jog direction can be switched by ▲ or ▼ on the operation panel. For details on the setting of jog frequency and jog stop mode, please refer to the introduction of f701 and f702.

## 5.3. Power on

Before powering on, be sure to check and confirm each item in Table 5.2 , otherwise it may be dangerous.

Table 5.2 Check items before power on

Item	Description
Input power voltage	Check whether the power supply voltage is connected correctly (three-phase AC380V~ 480V, 50/60Hz); The power input terminals R/L1, S/L2, T/L3 are connected correctly and reliably; The inverter and motor are grounded correctly.
Main circuit output terminal	The inverter output terminals U, V, W and the motor three-phase input terminals are connected correctly and reliably.
Control circuit terminals	The connection between the control circuit terminals and other control devices is reliable; All control circuit terminals are in the OFF state, and the inverter does not run when powered on.
Load status	Motor load status (connection status with mechanical system).

After the VFD is switched on, the keyboard panel enters into Powering-on mode. The displayed value type at Powering-on mode is determined by the setting value of parameter f610.

## 5.4 Running

### 5.4.1. Local control mode

VFD provide two control modes: local and remote. The mode is set with parameter f601.

At local control mode, both the command source and frequency setting source of the VFD are set through the keyboard panel:

(1) Command source is given through RUN and STOP keys in order to run or stop the motor.

(2) Frequency is given by ▲ and ▼ keys.

(3) Motor rotation direction: ENTER+ ▲——Setting motor rotation as Forward;

ENTER+ ▼——Setting motor rotation as Reverse (confirm the setting of f522) ;

Parameter f522 is used to limit the ability of the motor to rotate only in a single direction.

(4) Fault reset: When fault occurred, press STOP key, if show as A-00, Press STOP key again, finish fault reset function, Please see parameter f600.

### 5.4.2 Remote control mode

In remote mode, the command source and frequency setting source of the inverter need to be set through parameters f002 and f003 respectively. The two can be combined in any way. For details, see parameters f002 and f003.

The following mainly introduces the wiring methods and parameter settings of six remote control modes, namely:

- (1) 2-wire control (including deceleration stop and free stop);
- (2) 3-wire control (deceleration stop and free stop);
- (3) UP/DOWN acceleration and deceleration control;
- (4) Multi-speed control;
- (5) Jog control.

#### (1) Remote mode example 1: 2-wire control

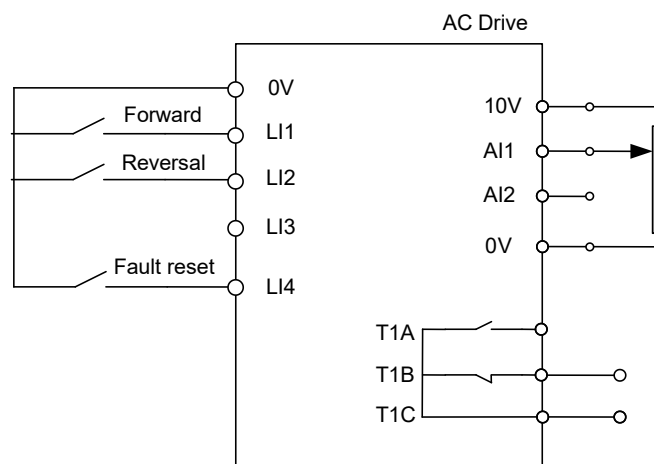

Figure 5.7 Example of 2-wire control wiring diagram

Table 5.3 2 - wire control parameter configuration (negative logic)

Code	Parameter	Settings (Deceleration stop)	Settings (Free stop)
f002	Selection of run command	0	0
f003	Selection of frequency command selection	1	1
f300	AI1 input function (analog or logic selection)	0	0
f301	LI1 logic input function	2	2
f302	LI2 logic input function	3	3
f304	LI4 logic input function	10	10
f305	Analog input mode setting	0	0
f306	Logic Input Type Selection *	1	1
f309	Forced valid logic input function	1	1
f310	Forced valid logic input function 2	0	0
f522	Motor reverse prohibition	0	0
f523	Motor stop type	0	2

**(2) Remote mode example 2: 3-wire control (negative logic)**

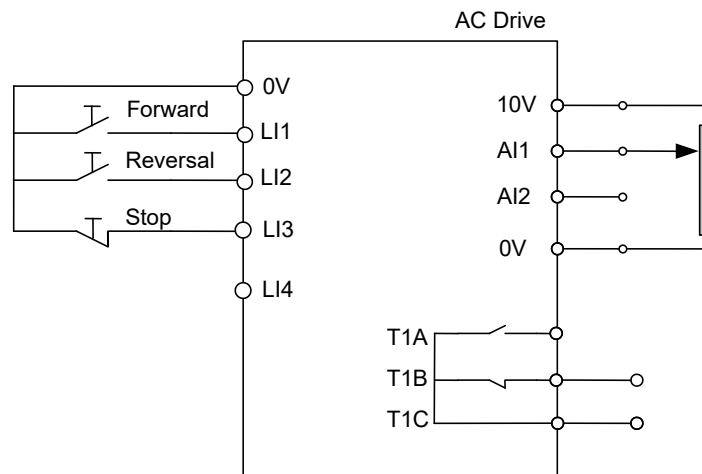

Figure 5.8 Example of 3-wire control (negative logic) wiring diagram

Table 5.4 3 - wire control parameter configuration (negative logic)

Code	Parameter	Settings (Deceleration stop)	Settings (Free stop)
f002	Run command selection	0	0
f003	Frequency command selection	1	1
f300	AI1 input function (analog or logic selection)	0	0
f301	LI1 logic input function	2	2
f302	LI2 logic input function	3	3
f303	LI3 logic input function	30	30

Code	Parameter	Settings (Deceleration stop)	Settings (Free stop)
f305	Analog input mode setting	0	0
f306	Logic Input Type Selection *	1	1
f309	Force valid logic input	1	1
f310	Force valid logic input 2	0	0
f522	Motor reverse prohibition	0	0
f523	Motor stop type	0	3

**(3) Remote mode example 3: UP/DOWN acceleration/deceleration (negative logic)**

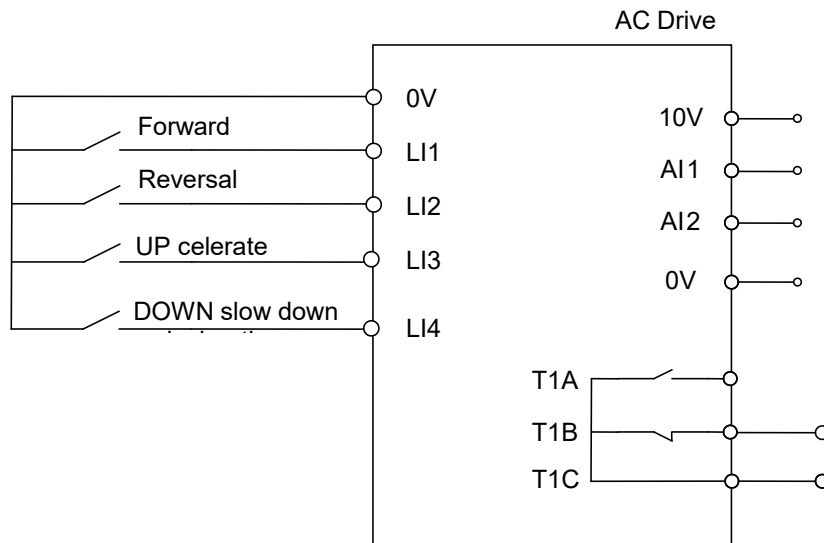

Figure 5.9 Example of UP/DOWN acceleration/deceleration wiring diagram

Table 5.5 UP/DOWN acceleration/deceleration parameter configuration

Code	Parameter	Setting
f002	Selection of run command	0
f003	Selection of frequency command selection	5
f301	LI1 logic input function	2
f302	LI2 logic input function	3
f303	LI3 logic input function	23
f304	LI4 logic input function	24
f306	Logic Input Type Selection *	1
f309	Force valid logic input	1
f310	Force valid logic input 2	0
f522	Motor reverse prohibition	0

**(4) Remote mode example 4: Multi-speed control (negative logic)**

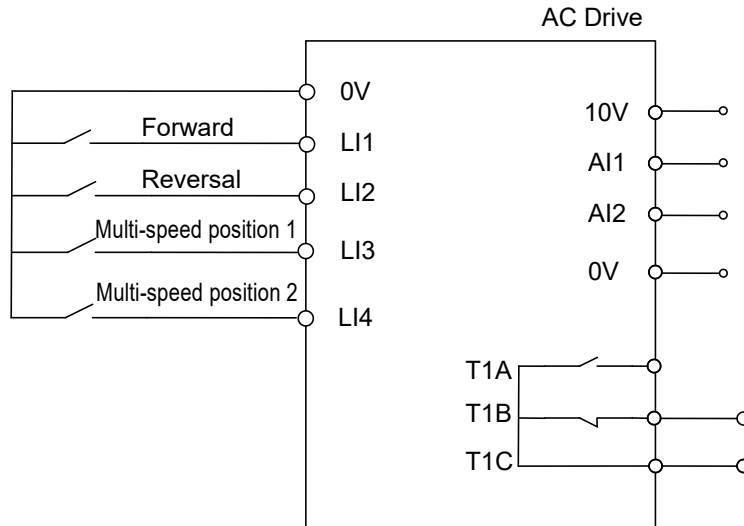

Figure 5.10 Example of Multi-speed control wiring diagram

Table 5.6 Multi-speed control parameter configuration (negative logic)

Code	Parameter	Setting
f002	Selection of run command	0
f003	Selection of frequency command selection	5
f301	LI1 logic input function	2
f302	LI2 logic input function	3
f303	LI3 logic input function	6
f304	LI4 logic input function	7
f306	Logic Input Type Selection	1
f309	Force valid logic input	1
f310	Force valid logic input 2	0
f522	Motor reverse prohibition	0
f000	Frequency digital setting of inverter	Equivalent to ultra-speed 0
f716	Multi-speed 1	Multi-speed 1
f717	Multi-speed 2	Multi-speed 2
f718	Multi-speed 3	Multi-speed 3

Note: How to set f000: After the inverter is powered on, it displays 0.0. Press ▲ or ▼ to edit the number f000 and press ENT to save.

**(5) Remote mode example 5: Jog control (negative logic)**

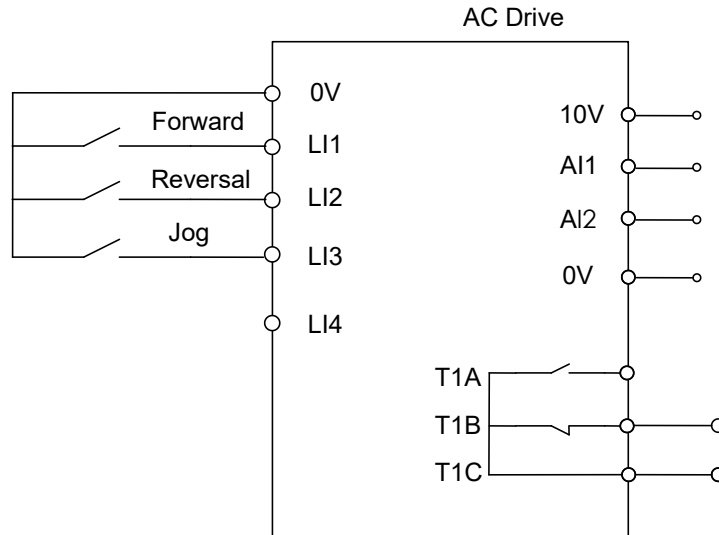

Figure 5.11 Example of wiring for JOG control

Table 5.7 Parameter configuration of JOG control (Negative logic)

Code	Parameter	Set Value
f002	Selection of run command	0
f301	LI1 logic input function	2
f302	LI2 logic input function	3
f303	LI3 logic input function	4
f306	Logic Input Type Selection *	1
f309	Force valid logic input	1
f310	Force valid logic input 2	0
f522	Motor reverse prohibition	0
f701	Jog frequency	Customize
f702	Inching stop mode	Customize

## 6. DETAILED PARAMETER DESCRIPTION

### 6.1. Basic parameter group

NO.	Parameter Name	Setting Range	Default
f000	Operation frequency of keypad	f009~f008	0.0

When power on, the VFD displays the operation frequency (when operation stopped, "0.0" is displayed, see f610. Then press the ▲ key or the ▼ key to change the operation frequency (even during operation).

Press ▲ move the frequency up. Press ▼ move the frequency down, Press the ENT key to save the operation frequency f000, and the set frequency are displayed alternately.

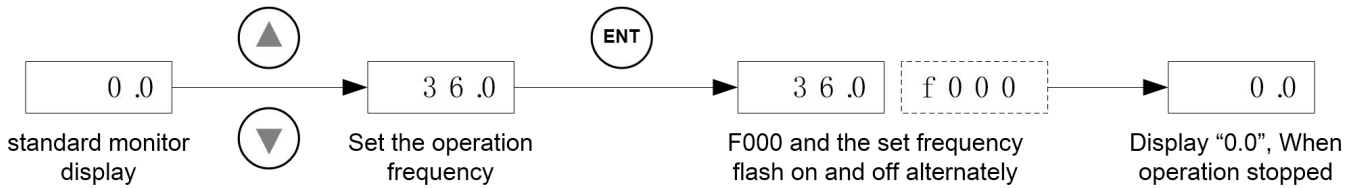

Figure 6.1 Procedure of setting f000

Note1: when set f003=3, f000 is effective as the frequency command.

Note2: Pressing the ▲ key or the ▼ key will change the operation frequency even during operation.

NO.	Parameter Name	Setting Range	Default
f001	V/F control mode selection	0~3	0

0: V/F constant. When one single VFD is required to drive more than one motor, please select V/f control mode if motor automatic tuning can not be correctly performed or there is no other access to acquire parameters of controlled motor. To increase the torque further, increase the setting value of the manual torque boost.

1: Variable torque. This is appropriate for load characteristics of such things as fans, pumps and blowers in which the torque in relation to load rotation speed is proportional to its square.

2: Sensor-less vector control. Using sensor-less vector control with a standard motor will provide the highest torque at the low speed ranges.

(1) Provides large starting torque.

(2) Effective when stable operation is required to move smoothly up from the low speeds.

(3) Effective in elimination of load fluctuations caused by motor slippage.

3: Energy saving mode. Energy can be saved in all speed areas by detecting load current and flowing the optimum current that fits the load.

Note: To use vector control and automatic energy saving, motor constant setting (motor tuning) is required.

NO.	Parameter Name	Setting Range	Default
f002	Command mode selection 1	0~2	1

0: Terminal board. ON and OFF of an external signal Runs and stops operation.

1: Keypad. Press the <RUN> and <STOP> keys on the keypad to start and stop.

2: Serial communication. Run and stop through serial communication.

Note: When under local control (f601=0), f002 setting is ignored, Keypad is always effective.

NO.	Parameter Name	Setting Range	Default
f003	Frequency setting mode selection 1	0~8	3

0: Built-in potentiometer.

1: AI1 input. Frequency command is set by means of a signal from an external input device (AI1 terminal: 0-5V, 0-10Vdc or 4-20mAdc).

2: AI2 input. An external signal (AI2 terminal: 0-10Vdc) is used to specify a frequency command.

3: Keypad (f000). Press the <▲> key or the <▼> key on either the keypad or the expansion panel (optional) to set frequency.

4: Serial communication. Frequency command is set by commands from an external control unit.

5: UP/DOWN setting from external contact. Terminals are used to specify an up/down frequency command.

6: AI1+AI2.

7: PID setting of keypad.

8: Simple PLC running option

Note 1: When under local control(f601=0), f003 setting is ignored, and f000 is always effective.

Note 2: In the case when there is no valid frequency command (e.g, frequency command is under starting frequency setting f503), the motor does not run even if the VFD receives the run command. At this time the RUN led on the keypad blinks.

Note 3: When f003 = 7, use f830 or f916 as the main PID setting.

NO.	Parameter Name	Setting Range	Default
f004	Command mode selection 2	0~2	0

Setting method is the same as f002.

Note: Switching operation between f002and f004 can be set input terminal function 67 (or 68) beforehand to an input contact terminal. When switching the terminal operation mode to panel operation mode:

If f502 = 1, the motor will keep the running status before switch operation.

If f502 = 0, the motor stops regardless the running status before the switch operation.

NO.	Parameter Name	Setting Range	Default
f005	Frequency setting mode selection 2	0~8	2

Setting method is the same as f003.

Note: About switching between f003 and F005operation, see f006.

NO.	Parameter Name	Setting Range	Default
f006	Frequency priority selection	0~3	0

0: Switch between f003 and f005

When f006 =0, switch between two frequency /PID given source f003 or f005 with a logical input;

1: Switch is disabled

When f006=1, the switch is disabled



At this point, if f021 =0, take f003 as the frequency /PID given channel; otherwise, determine the frequency /PID given source according to the setting of f021

2: Switch between f003 and f021 selected frequency /PID source

When f021 =0, frequency /PID given source is determined by f003.

When f021≠0, switch between f003 and the given source of f021 selected frequency /PID with a logical input

3: Switch between f005 and f021 selected frequency /PID source

When f021 =0, frequency /PID given source is determined by f003.

When f021≠0, switch between f005 and the given source of f021's selected frequency /PID with a logical input

Note: To use this feature, a logical input must be defined as function 20, given the frequency /PID source switch

When the defined logic input is OFF, the frequency /PID given source is determined by f003

When the defined logical input is ON, the frequency converter determines the frequency /PID given source by f005 or f021

NO.	Parameter Name	Setting Range	Default
f007	Maximum frequency	30.0 ~ 400.0 Hz	50.0
f008	Upper limit frequency	0.5 Hz ~F007	50.0
f009	Lower limit frequency	0.0 Hz ~F008	0.0

f007 sets the range of frequencies output by the VFD (maximum output values). This frequency is used as the reference for acceleration/deceleration time.

f008 and f009 set the upper and lower limit frequency that determines motor rotation speed range.

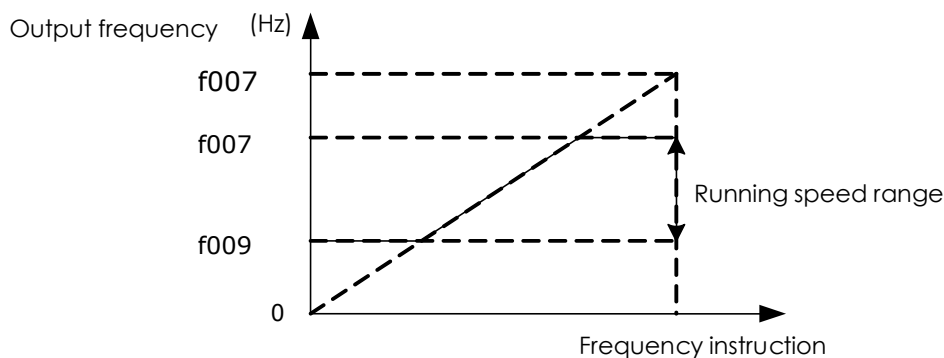

Figure 6.2 Relation of f007, f008, f009 and running speed

Note1: Set f007, f008, f009 carefully. The motor output frequency is affected not only by these three parameters, but also by start frequency, DC braking initial frequency and skip frequency.

Note 2: The following condition must be true when setting up these parameters:  $f009 \leq f008 \leq f007$ .

NO.	Parameter Name	Setting Range	Default
f010	Acceleration time 1	0.0 ~ 3200 s	varies by model
f011	Deceleration time 1	0.0 ~ 3200 s	varies by model

f010 sets the time that it takes for the VFD output frequency to go from 0Hz to maximum frequency f007.

f011 programs the time that it takes for the VFD output frequency to get from maximum frequency f007 to 0Hz.

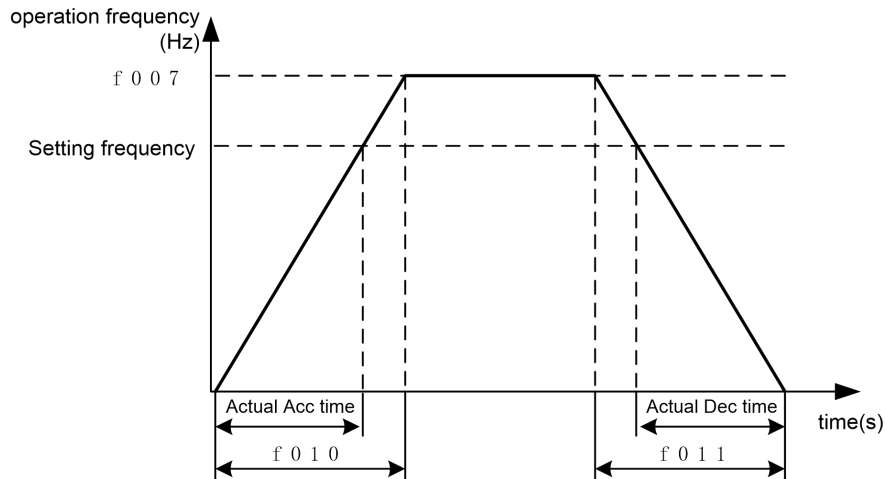

Figure 6.3 Definition of acceleration/deceleration time

When the acceleration/deceleration time is set at 0.0 seconds, the VFD speed increases or reduces within 0.1 seconds.

If the programmed value is shorter than the optimum acceleration/deceleration time determined by load conditions, overcurrent stall or overvoltage stall function may make the acceleration/deceleration time longer than the programmed time. If an even shorter acceleration/deceleration time is setted, there may be an over current trip or overvoltage trip for VFD protection.

Note: See f518, f520, f519 and f521.

NO.	Parameter Name	Setting Range	Default
f012	PWM carrier frequency	1.5 ~ 12.0 kHz	varies by model

Increase of the switching frequency may reduce the magnetic noise of the motor. However, enhancement of switching frequency will increase heat dissipation. In the event of increase of switching frequency, the capacity of the VFD may require corresponding derating. Normally it is unnecessary to change the parameter because we have done the reasonable setup when ex-factory.

PWM carrier frequency	motor's magnetic noise	Leakage Current	Inverter heat dissipation
2kHz	increase	decrease	decrease
4kHz	↑	↑	↑
12kHz	decrease	increase	increase

Figure 6.4 Impact on VFD performance by changing carrier frequency

Table 6.1 default carrier frequency value of different model capacity

Model	Max. of F300 (kHz)	Min. of F300 (kHz)	default of F300 (kHz)
0.4 ~ 11 kW	12.0	1.5	4.0
15 ~ 30 kW	8.0	1.5	4.0
37 ~ 500 kW	4.0	1.5	4.0

Note: Although the electromagnetic noise level is reduced, the motor acoustic noise may be increased.

NO.	Parameter Name	Setting Range	Default
f013	Carrier frequency control mode selection	0~1	1

0: Carrier frequency not reduced automatically

1: Carrier frequency reduced automatically.

Reduction of rated current will be required if the PWM carrier frequency is set high.

When the PWM carrier frequency is set high, selecting “Carrier frequency not reduced automatically” may causes the VFD to be tripped (overheat) more easily than selecting “Carrier frequency reduced automatically “.

Switching frequency level will be automatically controlled in case of overheat trip in the VFD. If the VFD detects upcoming overheat fault, it will lower the switching frequency to reduce the heat dissipation from the drive. With the temperature tending to normal, the switching frequency will return to the level selected by f012.

NO.	Parameter Name	Setting Range	Default
f014	Random PWM mode	0~1	0

0: Disable.

1: Enable. The random mode reduces motor electromagnetic noise by changing the PWM pattern.

NO.	Parameter Name	Setting Range	Default
f015	Automatic acceleration/deceleration	0~2	0

0: Disabled (manual).

1: Automatic (at acceleration & deceleration)

2: Automatic (only at acceleration)

Adjusts the acceleration/deceleration time automatically within the range of 1/8 to 8 times as long as the time set with the (f010 or f011), depending on the current rating of the VFD.

When automatically setting acceleration/deceleration time, always change the acceleration /deceleration time so that it conforms to the load. The acceleration/deceleration time changes constantly with load fluctuations. For VFD that requires a fixed acceleration/deceleration time, use the manual settings (f010 and f011), and set f015 = 0.

Setting acceleration/deceleration time (f010 and f011) in conformance with mean load allows optimum setting that conforms to further changes in load.

Use this parameter after actually connecting the motor.

When the VFD is used with a load that fluctuates considerably, it may fail to adjust the acceleration or deceleration time in time, and therefore may be tripped.

Note: Manual acceleration and deceleration time may still be restrained by motor current amplitude limit (See f107) and overvoltage fault protection (See f415) and overvoltage fault operation level. function (See f416).

NO.	Parameter Name	Setting Range	Default
f016	Factory reserved		

NO.	Parameter Name	Setting Range	Default
f017	Parameter setting macro function	0~19	0

0: Default value.

1: 2-wire control (Negative logic mode, ramp stop).

2: 3-wire control (Negative logic mode, ramp stop).

3: External input UP/DOWN setting (Negative logic mode, slowdown stop).

4 ~ 16: Factory reserved

17: PID sleep & Wake Control (f003 =7 f910 =0.1s f911 =75.0% f915 =5.0s f919 =38.0Hz)

18: PID basic control (f002 =1 f003=7 f367=1 f523=2 f900 =1 f917=100 f918 =20)

19: Factory reserved

Note 1: All the setup is available only under remote control mode (f601=1) or it cannot recover to the default value even you setup f017=0. After setting f601=1, f017 will recover to 0. If we request 2-wire control mode, we just set f017=1 and confirm the VFD is under remote control mode.

Note 2: Negative logic means the common point of all input terminal is connected to "0V" terminal on VFD, while positive logic mode connected to "24V" terminal, see f306.

Note 3: 1<sup>ST</sup> LED Display on the left is the value for f017 last setting

NO.	Parameter Name	Setting Range	Default
f018	Factory reserved		
f020	Factory reserved		

NO.	Parameter Name	Setting Range	Default
f021	Primary and secondary frequencies /PID are given	0 ~ 4	0

0: Single channel given

When f006 =0, switch between two frequency /PID given source f003or f005 with a logical input;

When f006 ≠0, frequency /PID given source is determined by f003.

1: f003 + f005

When f006 =0/1, take the sum of frequency /PID given by f003 and f005 as the final given, and its value is limited by upper and lower limits.

When f006=2, switch between f003 and (f003+ f005) with a logical input;

When f006=3, switch between f005 and (f003+f005) with a logical input.

2: f003-f005

When f006 =0/1, the difference between the frequency /PID given by f003 and f005 is taken as the final given value, and its value is limited by the upper and lower limits.

When f006=2, switch between f003 and (f003-f005) with a logical input;

When f006=3, switch between f005 and (f003-f005) with a logical input.

3: MAX (f003, f005)

Whenf006 =0/1, the maximum value of frequency /PID given by f003 and f005 is taken as the final given value, which is limited by upper and lower limits.

When f006=2, switch between f003 and MAX (f003, f005) with a logical input;

When f006=3, switch between f005 and MAX (f003, f005) with a logical input.

4: MIN (f003, f005)

When f006 =0/1, the minimum value of frequency /PID given by f003 and f005 is taken as the final given value, which is limited by upper and lower limits.

When f006=2, switch between f003 and MIN (f003, f005) with a logical input;

When f006=3, switch between f005 and MIN (f003, f005) with a logical input.

NO.	f021	f006	Final frequency setting
1	0	0	Switch between f003 and f005 with logical input
2	0	1/2/3	f003
3	1/2/3/4	0/1	f021 The selected given source
4	1/2/3/4	2	Switch between f003 and the given source selected by f021 with logical input
5	1/2/3/4	3	Switch between f005 and the given source selected by f021 with logical input

Example 1: when f003+ f005 operation and f005=3/7, press ▲▼ button to adjust the frequency /PID of f003 channel, and can increase or decrease.

- The set remains unchanged when the machine stops; When the power is off, it is not saved. After the power is on, it is the original set of f003 channel. Set to:

Frequency given: f900 =0, f003 = any, f005 =3, f021 =1, f024 =1 or 4.

PID given: f900 ≠0, f003= any, f005 =7, f021 =1, f024=1 or 4.

- When the machine stops or power is switched off, the set is not saved, and the original set of f003 channel is restored. Set to:

Frequency given: f900 =0, f003 = any, f005 =3, f021 =1, f024 =2 or 5.

PID given: f900 ≠0, f003= any, f005 =7, f021 =1, f024 =2 or 5.

Example 2: when f003± f005 is calculated and f005 =5, the frequency /PID of f003 channel can be adjusted directly through UP/DOWN function, and can be increased or decreased. ( Applicable to both frequency setting and PID setting)

- The set remains unchanged when the machine stops;

Set as: f003= any, f005 =5, f021 =1 or 2, f023 =25, f303 =23, f304 =24, f323 =25;

It is suggested to set f324 =4 to decide whether to save after power off.

- Do not save when shutdown and power down, restore to the original f003 channel.

Set to: f003= any, f005 =5, f021 =1 or 2, f023 =25, f303 =23, f304 =24, f323 =25 (must be f323= f023 based on f324 =6), f324 =4, f310 =75.

NO.	Parameter Name	Setting Range	Default
f022	f005 frequency given coefficient	0.0~ 100.0%	100.0 %
f023	f005 frequency bias given	0.0Hz~400.0Hz	0.0Hz

When f021 =1 (f003+ f005) or 2 (f003-f005) and f005 =0 (keyboard panel potentiometer), or 1 (AI1), or 2 (AI2), or 5 (UP/DOWN), f022 and f023 are used to adjust the given amount of f005.

Example 1: Processing with a given frequency

The final frequency of f005 channel is given = (the original frequency of f005 channel is given - f023) \* f022.

Example 2: processing given by PID (note: consider the original f005 as a given frequency here)

The final frequency PID given for f005 channel = f022 \*f917 \* (the original frequency given for f005 channel - f023)/f007.

Note: The final frequency /PID given for f005 channel may be positive or negative.

NO.	Parameter Name	Setting Range	Default
f024	Lower limit selection and f005= 3/7 setting	0~ 5	0

f024 contains two features:

Function 1: Select the lower limit value of panel potentiometer/f000 /UP\_DOWN;

Function 2: When selecting f021 =1(f003 + f005) and f005 =3 (given frequency) or 7(PID given), press ▲▼ button to adjust the treatment method of given frequency

f024	Panel potentiometer/f000/UP_DOWN given lower limit selection	When f021 =1 (f003+ f005) and f005 = 3/7, press ▲▼ button to adjust a given treatment
0		Press button ▲▼ to adjust the value of f000 and use f000 as the given source of f005
1	(1) Frequency given: f009	Press button ▲▼ to adjust f003 channel on the given basis, give keep the same when stop; When the power is off, it is not saved. After the power is on, it is the original set of f003 channel.
	(2) PID given:f917 * f009 / f007	
2		Press button ▲▼ to adjust f003 channel on the given basis, don't save the given when stop and power off, restore to the original given of f003 channel.
3		Press button ▲▼ to adjust the value of f000 and use f000 as the given source of f005
4	0.0Hz	Press button ▲▼ to adjust f003 channel on the given basis, give keep the same when stop; When the power is off, it is not saved. After the power is on, it is the original set of f003 channel.
5		Press button ▲▼ to adjust f003 channel on the given basis, don't save the given when stop and power off, restore to the original given of f003 channel.

NO.	Parameter Name	Setting Range	Default
f099	Manufacturer reserve (same as f020)	-	-

## 6.2. Motor and its protection parameter group

NO.	Parameter Name	Setting Range	Default
f100	Auto-tuning	0~2	0

0: Auto-tuning disabled (use of internal parameters).

1: Application of individual settings of f203 (after execution: 0).

2: Auto-tuning enabled (after execution: 0).

When auto-tuning, set the following parameters at least, as specified on the nameplate of the motor: f101~f104.

Set f100 to 2 before the start of operation. Tuning is performed at the start of the motor then.

Check to be sure that the setting of the parameter f101 and that of the parameter f102 agree with the base frequency (rated rotational speed) and base frequency voltage (rated voltage) of the motor to be operated, respectively. If not, set the parameters correctly.

When using the VFD to control the operation of a motor smaller in capacity by one grade or more, be sure to set the motor rated current setting parameter (f103) properly.

Vector control may not operate properly if the motor capacity differs from the applicable rated capacity of the VFD by more than two grades.

If current waveforms oscillate during operation, increase the speed control stability factor (f208). This is effective in suppressing oscillation.

Precautions on auto-tuning:

(1) Conduct auto-tuning only after the motor has been connected and operation completely stopped. If auto-tuning is conducted immediately after operation stops, the presence of a residual voltage may result in abnormal tuning.

(2) Voltage is applied to the motor during tuning even though it barely rotates. During tuning, "tun1" is displayed on the keypad.

(3) Tuning is performed when the motor starts for the first time after f100 is set to 2.

Tuning is usually completed within three seconds. If it is aborted, the motor will trip with the display of e-46 and no constants will be set for that motor.

(4) High-speed motors, high-slip motors or other special motors cannot be auto-tuned.

(5) Provide cranes and hoists with sufficient circuit protection such as mechanical braking. Without sufficient circuit protection, the resulting insufficient motor torque during tuning could create a risk of machine stalling/falling.

(6) If auto-tuning is impossible or an "e-46" auto-tuning error is displayed.

(7) If the VFD is tripped during auto-tuning because of an output phase failure (e-42), check if the VFD is connected to the correctly. A check for output phase failures is made during auto-tuning, regardless of the setting of the output phase failure detection mode selection parameter (f406).

NO.	Parameter Name	Setting Range	Default
f101	Base frequency 1	25.0~400.0 Hz	50.0
f102	Base frequency voltage1	50~660V	varies by model
f103	Motor rated current	varies by model	varies by model
f104	Motor rated speed	100~15000 rpm	varies by model

Set f101 ~f104, as specified on the nameplate of the motor

Note 1: Please set according to the motor nameplate parameters. Excellent control performance of vector control requires accurate motor parameters.

Note 2: Frequency converter provides parameter self-learning function. Accurate parameter self-learning comes from the correct input of motor nameplate parameters. In order to ensure the control performance, please try to ensure the inverter and the motor power match, otherwise, the inverter control performance will be significantly reduced.

Note 3: When the rated power of the field frequency converter is greater than the rated power of the motor, the motor overload protection should be enabled to prevent the motor from burning out. The motor overload protection function must set the following parameters:

- 1) f106 or f110 is set as the rated current of the motor nameplate.
- 2) f401=0 or 4, set to enable overload protection of ordinary motor or forced air-cooled motor.
- 3) f402 sets motor overload time, which defaults to 300 seconds.

NO.	Parameter Name	Setting Range	Default
f105	Motor no-load current	10.0~100.0%	varies by model

Set the ratio of the no-load current of the motor to the rated current. Enter the value in % that is obtained by dividing the no-load current by the rated current.

NO.	Parameter Name	Setting Range	Default
f106	Motor electronic thermal protection level 1	varies by model	varies by model

Set the motor rated current specified on the nameplate of the motor to f106. This parameter allows selection of the appropriate electronic thermal protection characteristics according to the particular rating and characteristics of the motor.

Note: If f603=1, f106 displays in amperes/volts. If f603=0, f106 displays in % term. The 100% standard value is the rated output current indicated on the nameplate.

NO.	Parameter Name	Setting Range	Default
f107	stall prevention level 1	varies by model	varies by model

This parameter adjusts the output frequency by activating a current stall prevention function against a current exceeding the f107 specified level.

Note 1: Do not set f107 under the rated motor no-load current. Otherwise the VFD will determine that it is performing motor braking and increase the frequency applied to the motor.

Note 2: If f603=1, f107 displays in amperes/volts. If f603=0, f107 displays in % term. The 100% standard value is the rated output current indicated on the nameplate.

Note 3: When VFD current is exceeding the f107 specified level:

- Output frequency is adjusted current exceeding the f107 specified level.
- During an OC alarm status, (that is, when there is a current flow in excess of the stall prevention level), the output frequency changes. At the same time, “---c” is displayed flashing on and off.

NO.	Parameter Name	Setting Range	Default
f108	Base frequency 2	25.0~400.0 Hz	50.0
f109	Base frequency voltage 2	50~660 V	varies by model



NO.	Parameter Name	Setting Range	Default
f110	Motor electronic-thermal protection level 2	varies by model	varies by model
f111	Stall prevention level 2	varies by model	varies by model

Setting method is the same as f101、f102、f106、f107.

Use the above parameters to switch the operation of two motors with a single VFD and to select motor V/F characteristics (two types) according to the particular needs or operation mode.

The f001 (V/F control mode selection) parameter is enabled only for motor1.If motor 2 is selected, V/F control will be given constant torque characteristics.

NO.	Parameter Name	Setting Range	Default
f112~f115	Factory reserved		

NO.	Parameter Name	Setting Range	Default
f120	Default setting	0~9	0

0: -

1: Standard default setting (Initialization)

2: Save user-defined parameters

3: Call user-defined parameters

4: Trip record clear

5: Cumulative operation time clear

6: Cumulative fan operation time record clear

7: Initialization of type information

8: P-type rating. (Nomal duty, for variable torque load characteristic like pumps and fans).

9: G-type rating. (Heavy duty, for constant torque load characteristic).

Note1: This function will be displayed as 0 during reading on the right. This previous setting is displayed on the left. Example: 1 0. f120 cannot be set during the VFD operating. Always stop the VFD first and then program.

Note 2: Even set f120=1, f300, f333, f334, f335, f336, f348, f349 will not be reset to their factory default settings.

Note 3: G-type and P-type: G-type refers to applications requiring constant torque output, while P-type applications with variable torque needs. The drive allows the user to select G-type or P-type ratings for the VFD depending on the application. Fans, pumps, and blowers should use P-type (f120 = 8), and other applications generally use G-type (f120 = 9). Differences between G-type ratings and P -type ratings for the drive include rated input and output current, overload capacity, carrier frequency, and current limit.

Duty types	Stall prevention level	overload tolerance	First digit of u000 display
G-type (heavy duty)	150%	150% rated output current for 60 s	“g” (e.g. g100)
P-type(Normal duty)	120%	120% rated output current for 60 s	“p” (e.g. p100)

Note 4:when set f120=1, the default setting is for G-type rating.

### 6.3. Motor control parameter group

NO.	Parameter Name	Setting Range	Default
f201	Supply voltage correction (limitation of output voltage)	0~3	3

0: Supply voltage uncorrected, output voltage limited.

1: Supply voltage corrected, output voltage limited.

2: Supply voltage uncorrected, output voltage unlimited.

3: Supply voltage corrected, output voltage unlimited.

If f201 is set to "0" or "2", the output voltage will change in proportion to the input voltage.

Even if the base frequency voltage (f102) is set above the input voltage, the output voltage will not exceed the input voltage.

The rate of voltage to frequency can be adjusted according to the rated motor capacity. For example, setting f201 to "0" or "1" prevents the output voltage from increasing, even if the input voltage changes when operation frequency exceeds the base frequency.

When the V/F control mode selection parameter (f001) is set to any number between 2 and 3, the supply voltage is corrected regardless of the setting of f201.

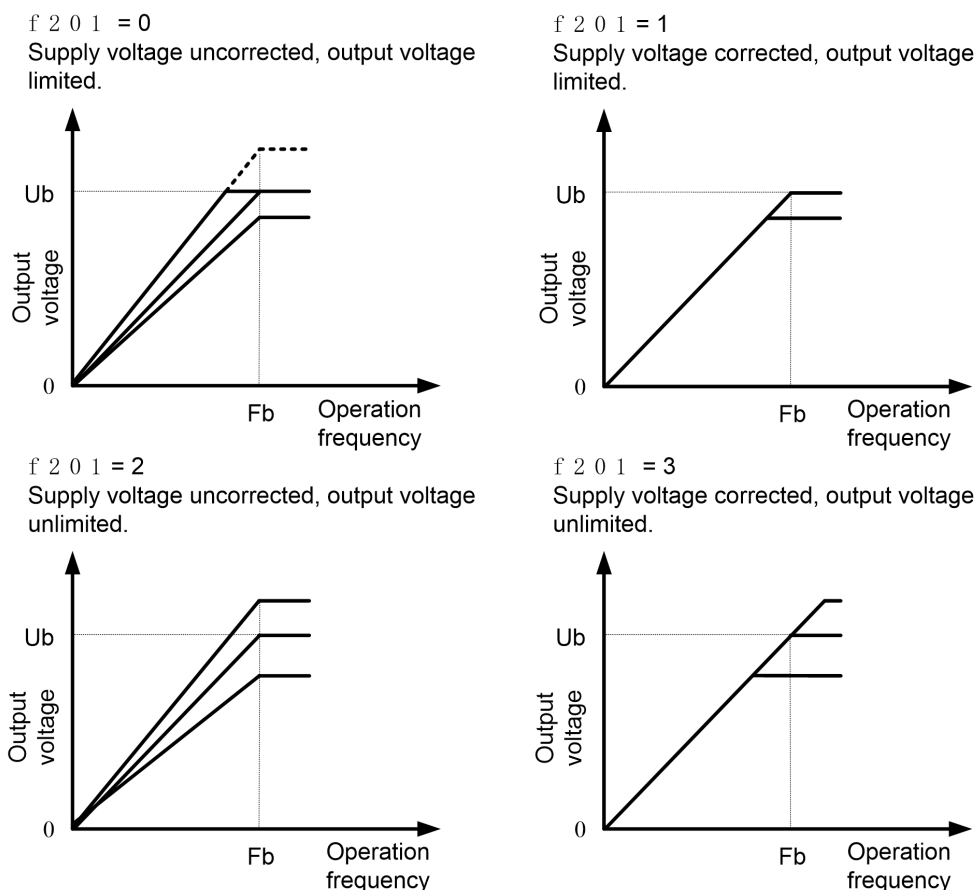

Figure 6.5 Description of voltage correct and voltage limit

NO.	Parameter Name	Setting Range	Default
f202	Voltage boost 1	0.0~30.0%	varies by model
f203	Torque boost	0.0~30.0%	varies by model

If torque is inadequate at low speeds, increase torque by raising the torque boost rate with these two parameters. Perform adjustments according to the actual operation.

f202 is effective when f001 is set to 0 (V/F constant) or 1 (square reduction).

f203 is effective when f001 is set to 2 (SVC mode).

Note: Be careful not to increase the voltage boost or torque boost rate too much because it could cause an overcurrent trip or e-45 at startup.

NO.	Parameter Name	Setting Range	Default
f204	Slip frequency gain	0~150 %	50

Set the compensation gain for the slipping of the motor. A higher slip frequency gain reduces motor slipping correspondingly.

Note1: After setting f104, set f204 to adjust in detail.

NO.	Parameter Name	Setting Range	Default
f205	Exciting current coefficient	100~130 %	100

f205 is used to fine adjust the magnetic field increase rate in low-speed range. To increase the torque in low-speed range, specify a larger value for f205.

Note: This parameter should be adjusted only when enough torque cannot be obtained, even though auto-tuning (f100 = 2) was made after the setting of the parameters f204 and f203. Note also that adjusting this parameter may cause an increase in the no-load current in low-speed range. If the no-load current exceeds the rated current, do not adjust this parameter.

NO.	Parameter Name	Setting Range	Default
f206	Voltage boost 2	0~30 %	varies by model

Setting method is the same as f202.

NO.	Parameter Name	Setting Range	Default
f207	Speed control response coefficient	1~150	40
f208	Speed control stability coefficient	1~100	20

Use these two parameters to adjust the speed of response and stability to the frequency command.

How to make adjustments according to the moment of inertia of the load:

The moment of inertia of the load (including that of the motor shaft) was set at the factory on the assumption that it would be three times as large as that of the motor shaft. If this assumption does not hold, calculate the values to be entered in f207 and f208, using the following equations.  $f207 = 40 \times \sqrt{a/3}$ ,  $f208 = 20 \times \sqrt{a/3}$ , Where 'a' is the times by which the moment of inertia of the load is larger than that of the motor. After the above adjustments, if necessary, make fine adjustments as described below.

- To increase(reduce) the response speed: Increase (reduce) the setting of f207.
- If overshooting or hunting occurs: Increase the setting of f208.
- If reduction gears or the like squeak: Increase the setting of f208.
- If an over-voltage trip occurs on completion of acceleration: Increase the setting of f208.

Note 1: When making the above adjustments, increase or decrease settings in steps of 10% or so while checking how things change.

Note 2: Depending on the settings of f207 and f208, the frequency may exceed the upper-limit frequency if the VFD is set so as to accelerate the load in the shortest possible time.

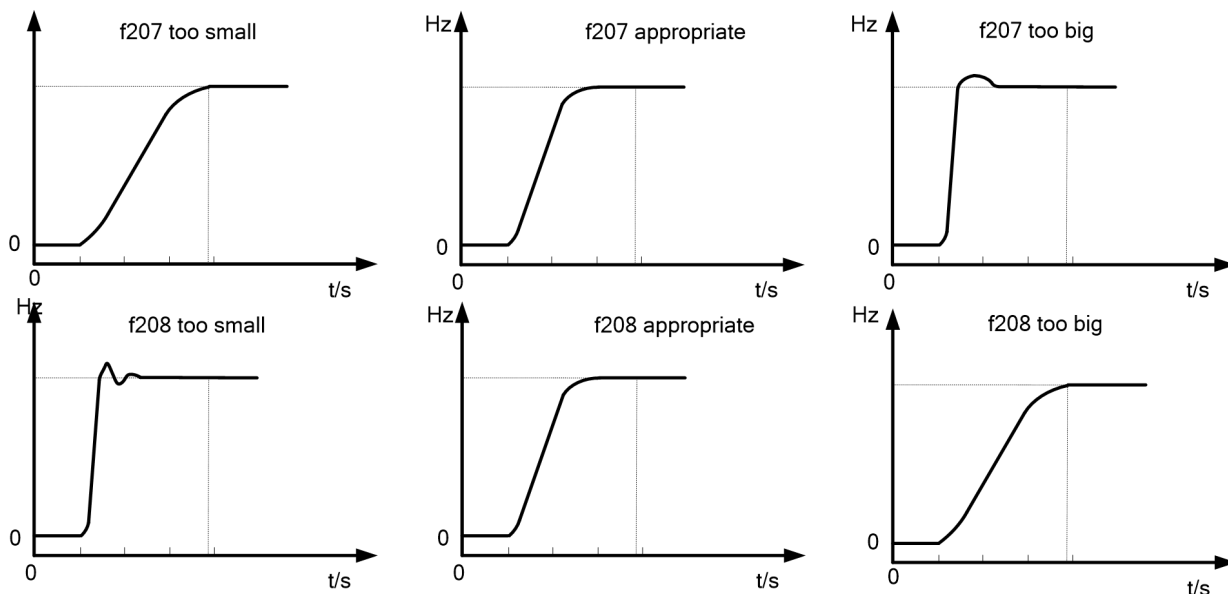

Figure 6.6 Relations of speed response and f207 , f208

NO.	Parameter Name	Setting Range	Default
f209	Stall prevention control coefficient 1	10~250%	100

Use this parameter along with f210 adjusts characteristics in a region in which the frequency is above the base frequency (region where the field is weak). If a heavy load is applied instantaneously (or transiently), the motor may stall before the load current reaches the current set with the stall prevention level 1 parameter (f107). In many cases, this kind of stall can be avoided by gradually reducing the setting of f209.

NO.	Parameter Name	Setting Range	Default
f210	Stall prevention control coefficient 2	50~150%	100

Using this parameter along with f209 adjusts characteristics in a region in which the frequency is above the base frequency (region where the field is weak).

\* How to make adjustments in a region (region where magnetic field is weak) above the base frequency:

A drop in supply voltage may cause fluctuations of the load current or vibration of the motor. In some cases, such phenomena can be eliminated by changing the setting of f210 to between 80 and 90. However, this may cause an increase in load current, so that it is also necessary to adjust the setting of the electronic thermal protective level 1 parameter (f106) properly according to the motor capacity.

NO.	Parameter Name	Setting Range	Default
f211	Maximam voltage adjustment coefficient	90~120%	104

Specify a larger value for f211 to secure as high an output voltage as possible in a region (region where magnetic field is weak) above the base frequency. Setting f211 to a larger value may cause the motor to vibrate or gears to squeak. If such a phenomenon occurs, do not adjust this parameter.

NO.	Parameter Name	Setting Range	Default
f212	Waveform switching adjustment coefficient	0.1~14.0kHz	14.0

Specify a larger value for f212 if switching from a waveform to another resulting in a considerable increase in vibration and noise in middle-speed range (region between the start frequency and the base frequency). If no improvement can be made by specifying a larger value, do not adjust this parameter.

NO.	Parameter Name	Setting Range	Default
f213- f216	Factory reserved		

NO.	Parameter Name	Setting Range	Default
f217	Multipoint profile V/F patter	0~2	0

0: factory reserved. 1: factory reserved.

2: Enable multipoint profile V/F patter.

The drive utilizes a set V/f pattern (f217 = 2) to determine the appropriate output voltage level for each relative to the frequency reference.

NO.	Parameter Name	Setting Range	Default
f218	Point 1 output frequency (F1)	0~f220	10.0
f219	Point 1 output frequency voltage (V1)	0~100%	20.0
f220	Point 2 output frequency (f2)	f218~f220	20.0
f221	Point 2 output frequency voltage (V2)	0~100%	40.0
f222	Point 3 output frequency (f3)	f220~f101	30.0
f223	Point 3 output frequency voltage (V3)	0~100%	60.0

Set up the V/f pattern with f218~f223 as shown in according to the load characteristic.

Note 1: The following condition must be true when setting up the V/f pattern :  $V1 < V2 < V3$ ,  $F1 < f2 < f3$ .

Note: Too high voltage output at low speed will cause a serious motor heat dissipation problem, or stall prevention alarm, or over current trip.

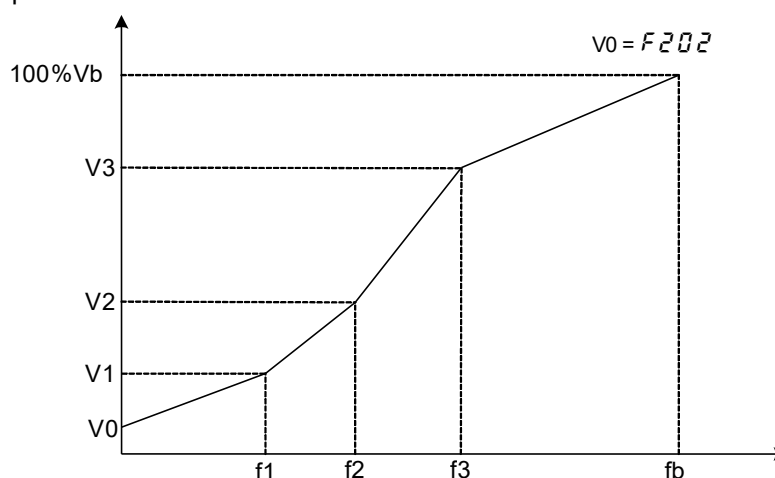

Figure 6.7 Multipoint profile V/F patter (f217 =2)

## 6.4. Process PID parameter group

NO.	Parameter Name	Setting Range	Default
f300	AI1 terminal function selection	0~2	0

0: AI1 - analog input

1: AI1 - contact input (Sink mode)

2: AI1 - contact input (Source mode)

This parameter allows you to choose between analog signal input and contact signal input for the AI1 terminal.

When using the AI1 terminal as analog input, be sure f305 is configured right (0~5VDC, 0~10VDC, or 0~20mA).

When using the AI1 terminal as contact input terminals in sink logic connection, be sure to insert a resistor between the 24V terminal and the VIA terminal. (Recommended resistance: 4.7k $\Omega$  ~10k $\Omega$  1/2W).

Note1: Not valid when capacity rating is at 15kw or above.

NO.	Parameter Name	Setting Range	Default
f301	Input terminal function for LI1	0~75	2
f302	Input terminal function for LI2	0~75	3
f303	Input terminal function for LI3	0~75	0
f304	Input terminal function for LI4	0~75	10

Use the above parameters to send signals from an external programmable controller to various control input terminals to operate and/or set the VFD. The desired contact input terminal functions can be selected from table 6.2.

Table 6.2 Description of input terminal function

Input terminal function NO.	Function name	Description
0	No function is assigned	Disabled
1	Standby terminal	ON: Ready for operation OFF: Coast stop (gate off)
2	Forward run command	2-wire operation ON: Forward run OFF: Slowdown stop
		3-wire operation OFF→ON: forward run.
3	Reverse run command	2-wire operation ON: Reverse run. OFF: Slowdown stop
		3-wire operation OFF→ON: Reverse run.
4	Jog run mode	ON: Jog run OFF: Jog run canceled
5	Acceleration/deceleration 2 pattern selection	ON: Acceleration/deceleration 2 OFF: Acceleration/deceleration 1 or 3
6	Preset-speed command 1	Selection of 15-speed with LI1 to LI4 (4 bits)
7	Preset-speed command 2	
8	Preset-speed command 3	
9	Preset-speed command 4	

Input terminal function NO.	Function name	Description
10	Reset command	ON: Acceptance of reset command ON → OFF: Trip reset
11	Trip stop command from external input device	OFF: No Trip ON: e-43 Trip stop according to the stop mode set by f403
13	DC braking command	OFF: No DC braking command ON: DC braking started. DC braking current level and DC braking time is set by f507 and f508 respectively.
14	PID control disabling	OFF: PID control enabled. ON: PID control disabled. The input terminal function of PID control disabling is used for switching between PID control and open-loop control. Clearance of PID integral value function can also be used.
15	Permission of parameter editing	ON: Parameter editing permitted OFF: Parameter editing prohibited (If f700 = 1)
16	Combination of standby and reset commands	ON: Simultaneous input from standby and reset commands
17	Frequency source switching to AI1	ON: Frequency source switched to AI1 OFF: Frequency source as per f003
18	Combination of forward run and jog run	ON: Forward jog operation
19	Combination of reverse run and jog run	ON: Reverse jog operation
20	Frequency setting source switching	ON: The VFD follows the speed setting set by f005 (when f011= 1). OFF: The VFD follows the speed setting set by f003.
21	No.2 Switching of V/F setting	ON: No.2 V/F setting (f001=0、 f108、 f109、 f110、 f206) OFF: No.1 V/F setting(f001、 f101、 f102、 f106、 f202)
22	No.2 motor switching	ON: No.2 motor(f001=0、 f108、 f109、 f110、 f111、 f206、 f518、 f519、 f511) OFF: No.1 motor (f001、 f010、 f011、 f101、 f102、 f106、 f107、 f202、 f510)
23	Frequency UP signal input from external contacts	ON: Increase in frequency
24	Frequency DOWN signal input from external contacts	ON: Reduction in frequency
25	Frequency UP/DOWN cancellation signal input from external contacts	OFF→ON: Resetting of UP/DOWN frequency by means of external contacts
26	inversion of trip stop command from external device	OFF: e-43 Trip stop according to the stop mode set by f403
27	Thermal trip stop signal input from external device	ON: e-25 Trip stop

Input terminal function NO.	Function name	Description
28	inversion of thermal trip stop signal input from external device	OFF: e-25 Trip stop
29	Forced switching from remote to local control	Enabled when remote control is exercised ON: Local control (setting of cmod, f002、 f003 和 f005) OFF: Remote control
30	Operation holding (stop of 3-wire operation)	ON: forward /reverse run held, 3-wire operation OFF: Slowdown stop
31	Forced switching of command mode and terminal board command	ON: Terminal board operation OFF: Setting of f002
32	Display cancellation of the cumulative power amount (kWh)	ON: Monitor display cancellation of the cumulative power amount (kWh)
33	Fire-speed control seef419	ON: Fire-speed operation (preset speed operation frequency f730) OFF: Normal operation
34	Coast stop (gate off)	ON: Coast stop (gate off)
35	Inversion of Reset	ON: Acceptance of reset command OFF→ ON: Trip reset
36	Forced switching of stall prevention level 2	ON: Enabled at the value of f111 OFF: Enabled at the value of f107
37	PID control integral value clear PID control integral value clear	ON: PID control integral value always zero OFF: PID control permitted
38	inversion of PID error signal	ON: PI error input = feedback – setting OFF: PI error input = setting – feedback
39	Forward running command + Acc&Dec curve 2	ON: The motor runs forward and accelerates along the ramp according to acceleration/deceleration curve 2. ON: Motor forward running, follow Acc&Dec curve 2 to do the ramp acceleration
40	Reverse running command + Acc&Dec curve 2	ON: Motor reverse running, follow Acc&Dec curve 2 to do the ramp acceleration
41	Forward running command + Multi-speed section 1	ON: Motor forward running and activate multi-speed section 1
42	Reverse running command + Multi-speed section 1	ON: Motor reverse running and activate multi-speed section 1
43	Forward running command + Multi-speed section 2	ON: Motor forward running and activate multi-speed section 2
44	Reverse running command + Multi-speed section 2	ON: Motor reverse running and activate multi-speed section 2



Input terminal function NO.	Function name	Description
45	Forward running command + Multi-speed section 3	ON: Motor forward running and activate multi-speed section 3
46	Reverse running command + Multi-speed section 3	ON: Motor reverse running and activate multi-speed section 3
47	Forward running command + Multi-speed section 4	ON: Motor forward running and activate multi-speed section 4
48	Reverse running command + Multi-speed section 4	ON: Motor reverse running and activate multi-speed section 4
49	Multi-speed section 1 + Acc&Dec curve 2	ON: activate Acc&Dec curve 2 and multi-speed section 1 at the same time
50	Multi-speed section 2 + Acc&Dec curve 2	ON: activate Acc&Dec curve 2 and multi-speed section 2 at the same time
51	Multi-speed section 3 + Acc&Dec curve 2	ON: activate Acc&Dec curve 2 and multi-speed section 3 at the same time
52	Multi-speed section 4 + Acc&Dec curve 2	ON: activate Acc&Dec curve 2 and multi-speed section 4 at the same time
53	Forward running command+Multi-speed section 1+ Acc&Dec curve 2	ON: activate Acc&Dec curve 2, forward running command and multi-speed section 1 at the same time
54	Reverse running command+Multi-speed section 1+ Acc&Dec curve 2	ON: activate Acc&Dec curve 2, reverse running command and multi-speed section 1 at the same time
55	Forward running command+Multi-speed section 2+ Acc&Dec curve 2	ON: activate Acc&Dec curve 2, forward running command and multi-speed section 2 at the same time
56	Reverse running command+Multi-speed section 2+ Acc&Dec curve 2	ON: activate Acc&Dec curve 2, reverse running command and multi-speed section 2 at the same time
57	Forward running command+Multi-speed section 3+ Acc&Dec curve 2	ON: activate Acc&Dec curve 2, forward running command and multi-speed section 3 at the same time
58	Reverse running command+Multi-speed section 3+ Acc&Dec curve 2	ON: activate Acc&Dec curve 2, reverse running command and multi-speed section 3 at the same time
59	Forward running command+Multi-speed section 4+ Acc&Dec curve 2	ON: activate Acc&Dec curve 2, forward running command and multi-speed section 4 at the same time

Input terminal function NO.	Function name	Description
60	Reverse running command+Multi-speed section 4+ Acc&Dec curve 2	ON: activate Acc&Dec curve 2, reverse running command and multi-speed section 4 at the same time
61	UP/DOWN speed clean up+ fault reset	When it is OFF to ON, clean up UP/DOWN speed input setup frequency level
62	Running permission+ Forward running command (only 2-wire control)	ON: Activate running permission and forward running command at the same time.
63	Running permission+ reverse running command (only 2-wire control)	ON: Activate running permission and reverse running command at the same time.
64	Acc&dec curve 3	ON: Motor follows acceleration curve 3
65	Acce/Dece curve 3 + Forward running command	ON: Activate forward running and acce/dece curve 3 command at the same time.
66	Acce/Dece curve 3 + Reverse running command	ON: Activate reverse running and acce/dece curve 3 command at the same time.
67	Command source switch	OFF: command source press f002 ON: command source press f002
68	Command source + frequency source switch	OFF: Command source press f002 and frequency source press f003 ON: Command source press f004 and frequency source press f005
69	Three-wire control stop reverse	OFF: Ready for running ON: decelerate along the ramp until stop
70	Reset when simple PLC stops	OFF: Command source is f002 ON : Command source is f004
71	Simple PLC time out	OFF: Invalid ON: Effective
72	Simple PLC pause	OFF: Invalid ON: Effective
73	PID control + frequency given source switch	OFF: Control disable + set f005 for the given frequency source ON: Control disable + set f003 for the given frequency source
74		OFF: Control disable + set f005 for the given frequency source ON: Control disable + set f003 for the given frequency source
75	(UP/DOWN) stop speed clearance	ON: (UP/DOWN) stop speed clear effective OFF: (UP/DOWN) stop speed clearance is invalid

Note1: AI1 and AI2 could be used as contact input terminals (see f300, f308, f313 and f314).

Note 2: The difference between 2-wire control and 3-wire operation configuration lies in whether logic input function 30 (3-wire control shutdown input) is used.

NO.	Parameter Name	Setting Range	Default
f305	AI1 voltage-current input selection	0~2	0

0:0~5V voltage signal input.

1:0~10V voltage signal input.

2: 0-20mA(4-20mA) current signal input.

Note: AI2 only accept 0~10VDC voltage signal input, setting value of f305 will not change the characteristic of AI2.

NO.	Parameter Name	Setting Range	Default
f306	sink/soruce mode selection	0~1	1

0: Source (Positive) logic terminal mode.

1: Sink (Negative) logic terminal mode

NO.	Parameter Name	Setting Range	Default
f307	AO voltage-current output selection	0~1	1

0: Current signal output.

1: Voltage signal output.

NO.	Parameter Name	Setting Range	Default
f308	Input terminal function of AI1	0~75	0

When f300 disabled, the set value of f308 cannot be read out.

When f300 set at 1 or 2, AI1 is enabled, and can be used as a contact input terminal.

NO.	Parameter Name	Setting Range	Default
f309	Always-active terminal selection 1	0~75	1
f310	Always-active terminal selection 2	0~75	0

f309 and f310 specifies an input terminal function that is always to be kept active (ON).

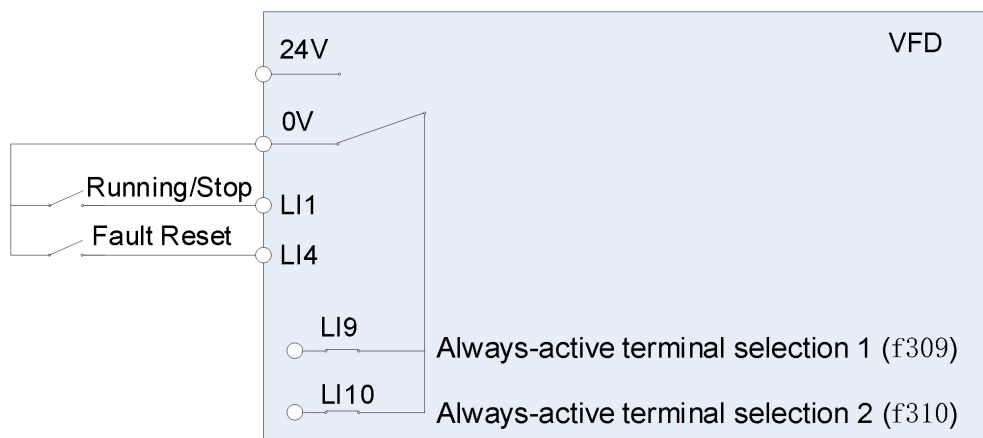

Figure 6.8 Always active terminal function

Note 1: Use f309 and f310 to assign input terminal function to LI9, LI10. LI9 and LI10 are virtual input contact terminal which are always activated. See Figure 6.8.

NO.	Parameter Name	Setting Range	Default
f311	Output terminal function A of LO1-CLO1	0~255	4
f312	Output terminal function B of LO1-CLO1	0~255	255

The set method is same as f315.

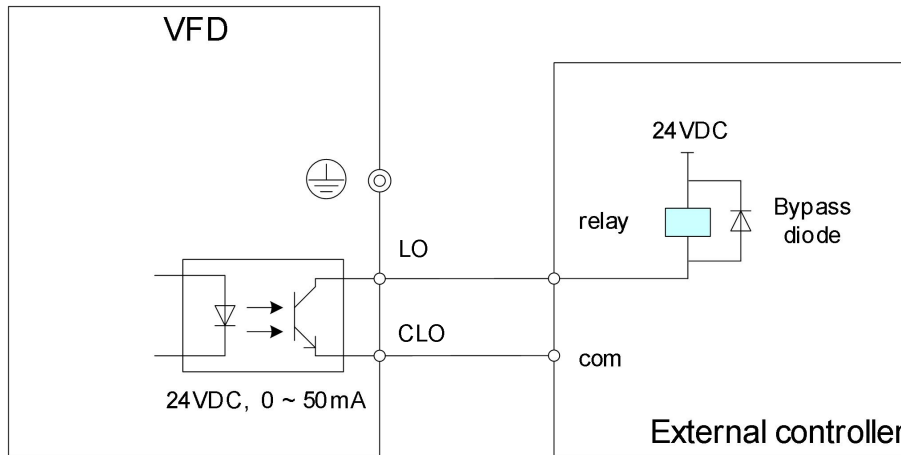

Figure 6.9 Output of LO-CLO wiring example

f312 could be used to remind of assisted status signal.

NO.	Parameter Name	Setting Range	Default
f313	AI1 terminal function selection	0	0

- 0: AI2 - analog input
- 1: AI2 - contact input (Sink)
- 2: AI2 - contact input (Source)

NO.	Parameter Name	Setting Range	Default
f314	Input terminal function of AI2	0~75	0

The set method is same as f301~f304.

NO.	Parameter Name	Setting Range	Default
f315	Output terminal function A of T1	0~255	40

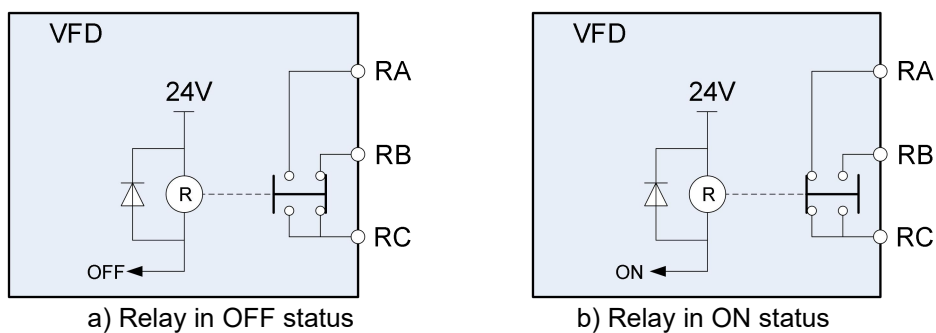

Figure 6.10 Description of relay status

Table 6.3 Description of output terminal function

Logic output Function Settings	Relay state	Operation
0	OFF	Output frequency $\leq$ lower limit frequency setting of f009
	ON	Output frequency $>$ lower limit frequency setting of f009
2	OFF	Output frequency $<$ upper limit frequency setting of f008
	ON	Output frequency = upper limit frequency setting of f008
4	OFF	Output frequency $<$ setting of f337
	ON	Output frequency $\geq$ setting of f337
6	OFF	Output frequency $>$ (set frequency + f339), or $<$ (set frequency - f339)
	ON	(frequency - f339) $<$ output frequency $<$ (set frequency + f339)
8	OFF	Output frequency $>$ (f338+f339), or $<$ (f338-f339)
	ON	(f338-f339) $<$ Output frequency $<$ (f338+f339)
10	OFF	Output frequency $\leq$ f338-f339
	ON	Output frequency $\geq$ f338+f339
12	OFF	Frequency commanded by f003or f005 $\neq$ AI1 value
	ON	Frequency commanded by f003or f005= AI1 value
14	OFF	Frequency commanded by f003or f005 $\neq$ AI2 value
	ON	Frequency commanded by f003or f005= AI2 value
16	OFF	AI1 value $\leq$ f340-f341
	ON	AI1 value $\geq$ f340+f341
18	OFF	AI2 value $\leq$ f342-f343
	ON	AI2 value $\geq$ f342+f343
20	OFF	Terminal other than AI2 selected as frequency command
	ON	AI2 selected as frequency command
22	OFF	Operation stopped
	ON	When operation frequency is output or during (a-07)
24	OFF	Not for ready for operation
	ON	Ready for operation (Input function of standby and run are not ON)
26	OFF	forward run
	ON	reverse run
28	OFF	remote control mode
	ON	local control mode
30	OFF	No Frequency converter fault (no fault output during automatic fault reset attempt)
	ON	Frequency converter fault

Logic output Function Settings	Relay state	Operation
32	OFF	Torque current is equal to or less than f412 - f413
	ON	Torque current is equal to or larger than f412 set value and longer than f414 set time.
34	OFF	The output current is equal to or larger than f408+f409
	ON	The output current is equal to or less than f408 for f410 set time
36	OFF	When VFD is not significant trip
	ON	When VFD is significant trip
38	OFF	When VFD is not insignificant trip
	ON	When VFD is insignificant trip
40	OFF	No Frequency converter fault
	ON	Frequency converter fault (out of order during automatic fault reset attempt)
42	OFF	alarm off
	ON	alarm on
44	OFF	calculated value of motor overload level < 50%
	ON	calculated value of motor overload level ≥ 50%
46	OFF	calculated value of brake resistor overload level < 50%
	ON	calculated value of brake resistor overload level ≥ 50%
48	OFF	Torque curren < (f412*70% - f413)
	ON	Torque curren ≥ f412*70%
50	OFF	Cumulative operation time < f428 setting
	ON	Cumulative operation time ≥ f428 setting
52	OFF	Calculation for parts replacement time is shorter than the preset time (internally preset)
	ON	Calculation for parts replacement time is equal to or longer than the preset time (internally preset)
54	OFF	Normal condition
	ON	PTC detected value ≥ 60% of protection level
56	OFF	Other than undervoltage detected
	ON	Undervoltage detected
58	OFF	Mechanical brake release
	ON	Mechanical brake not release
60	OFF	Motor is not in acceleration state
	ON	Motor is in acceleration state
62	OFF	Motor is not in deceleration state
	ON	Motor is in deceleration state

Logic output Function Settings	Relay state	Operation
64	OFF	Motor is not in acceleration or deceleration state
	ON	Motor is in acceleration or deceleration state
66	OFF	Heat sink temperature still not reach alarm value
	ON	Heat sink temperature reaches alarm value
68	OFF	PLC recycle is under running
	ON	After completing one PLC recycle, then export one On-pulse
70	OFF	Under running at one PLC section
	ON	After completing one PLC section, then export one On-pulse
72	OFF	The converter is not ready
	ON	The converter is ready to receive the running signal
74~79	OFF	Not used
	ON	Not used
80	OFF	L11 input is invalid
	ON	L11 input is valid
82	OFF	L12 input is invalid
	ON	L12 input is valid
84	OFF	PID feedback pressure equal to or below F627 - F628
	ON	PID feedback pressure is equal to or higher than F627 + F628
86	OFF	PID feedback pressure is equal to or below F918
	ON	PID feedback pressure is equal to or higher than F918 + F628
88~253	OFF	Not used
	ON	Not used
254	OFF	Relay Output always OFF
255	ON	Relay Output always ON

Note 1: Inversion logic can be obtained by add 1 to the output terminal function number. Example: f315=3 is the inversion logic action of f315=2.

Note 2: Output terminal function is available for LO1-CLO1、LO2-CLO2 (f311、f312、f373、f374)和 T1, T2 (f315、f359、f360).

Note 3: Significant trip including follows: e-02, e-03, e-05, e-06, e-07, e-12, e-25, e-31, e-32, e-33, e-36, e-41, e-42, e-43, e-46. Insignificant trip including follows: e-01, e-11, e-21, e-22, e-24.

NO.	Parameter Name	Setting Range	Default
f316	Output terminal logic selection of LO1-CLO1	0~1	0

0: f311 AND f312. The logical product (AND) of f311 and f312 will be output to LO1-CLO1.

1: f311 OR f312. The logical sum (OR) of f311 and f312 will be output to LO1-CLO1.

NO.	Parameter Name	Setting Range	Default
f317	LO1-CLO1 output delay	0~60.0 s	0.0

f317 specified the time of LO1-CLO1 output delay.

NO.	Parameter Name	Setting Range	Default
f318	Relay 1 closing delay time	0~60.0 s	0.0

f318 specifies the closing delay time of relay 1 normally open contact

NO.	Parameter Name	Setting Range	Default
f319	External contact input - UP response time	0.0~10.0s	0.1
f320	External contact input - UP frequency steps	0.0 Hz ~f007	0.1
f321	External contact input - DOWN response time	0.0~10.0s	0.1
f322	External contact input - DOWN frequency steps	0.0 Hz ~f007	0.1

These functions take effect when f003 or f005 is set to 5. Two input contact terminals are required to adjust the frequency command: one is used to increase the frequency command (see input terminal function 23), and the other is used to reduce the frequency command (see input terminal function 24). Use an input contact terminal to clear the frequency setting that accumulated by the UP/DOWN operation (see input terminal function 25).

Use f319~f322 set the frequency incremental/decremental gradient.

Frequency command incremental gradient =  $f320/f319$  setting time

Frequency command decremental gradient =  $f322/f321$  setting time

NO.	Parameter Name	Setting Range	Default
f323	Initial up/down frequency	0.0 Hz ~f007	0.0

To adjust the frequency starting at a specified frequency other than 0.0 Hz (default initial frequency) after turning on the VFD , specify the desired frequency using f323 (initial up/down frequency).

NO.	Parameter Name	Setting Range	Default
f324	Change of the initial up/down frequency	0~6	0

f324 Set	Whether f323 is saved when power is lost	f323 reset option
0	Do not save, f323 will not change every time the power is switched off or switched on.	f323 restores to f009 when reset with logical input function 25 (special reset) or 75 (stop reset).
1	Save, f323 is set to the last received frequency given when power is lost.	
2	Do not save, f323 will not change every time the power is switched off or switched on.	The f323 is restored to 0.0Hz when reset by the logical input function 25 (dedicated reset) or 75 (shutdown reset).
3	Save, f323 is set to the last received frequency given when power is lost.	
4	Do not save, f323 will not change every time the power is switched off or switched on.	f323 returns to its original value when it is reset by the logical input function 25



f324 Set	Whether f323 is saved when power is lost	f323 reset option
5	Save, f323 is set to the last received frequency given when power is lost.	(dedicated reset) or 75 (shutdown reset).
6	Record the initial value of f323, see note for details.	

Note: If f323 needs to return to its original value (i.e. : f324 =4 or 5) when it is reset through the logical input terminal function 25 or 75, it must set f324 =6 after setting f323, or set f323 on the basis of f324 =6 to record the original value of f323, otherwise the frequency after reset may be incorrect.

Example: when given a frequency through a single channel UP/DOWN, the frequency is not saved for each shutdown and power outage, and the frequency is restored to the original given frequency of f323.

◇ Settings are: f003=5, f021 =0, f023 =25, f303 =23, f304 =24, f310 =75,

f323 =25 (f323 must be set on f324=6 and f323=f023), f324=4.

NO.	Parameter Name	Setting Range	Default
f325	A11 input point 1 setting	0~100%	0
f326	A11 input point 1 frequency	0.0~400.0 Hz	0.0
f327	A11 input point 2 setting	0~100%	100
f328	A11 input point 2 frequency	0.0~400.0 Hz	50.0
f329	A12 input point 1 setting	0~100%	0
f330	A12 input point 1 frequency	0.0~400.0 Hz	0.0
f331	A12 input point 2 setting	0~100%	50
f332	A12 input point 2 frequency	0.0~400.0 Hz	50.0

These parameters adjust the output frequency according to the externally applied analog signal (0-5Vdc voltage, 0-10Vdc voltage, 4-20mAdc current) and the entered command for setting an external contact frequency, see figure 6.11.

Note 1: Do not set the same value to f325 and f327 (or f329 and f331), otherwise a-05 will alarmed.

Note 2: when adjust 4-20mAdc current input, set 20(%) to f325 (f327).

Note 3: analog input signal bias and slope could further adjust with the parameter between f333 and f336

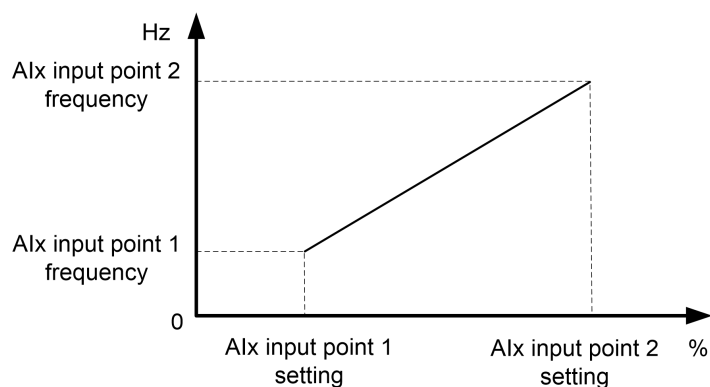

Figure 6.11 Relation between analog input and frequency setting

NO.	Parameter Name	Setting Range	Default
f333	AI1 input bias	0~255	varies by model
f334	AI1 input gain	0~255	varies by model
f335	AI2 input bias	0~255	varies by model
f336	AI2 input gain	0~255	varies by model

To fine adjust the frequency command characteristics for AI1/AI2 input, use the Parameters f333 to f336.

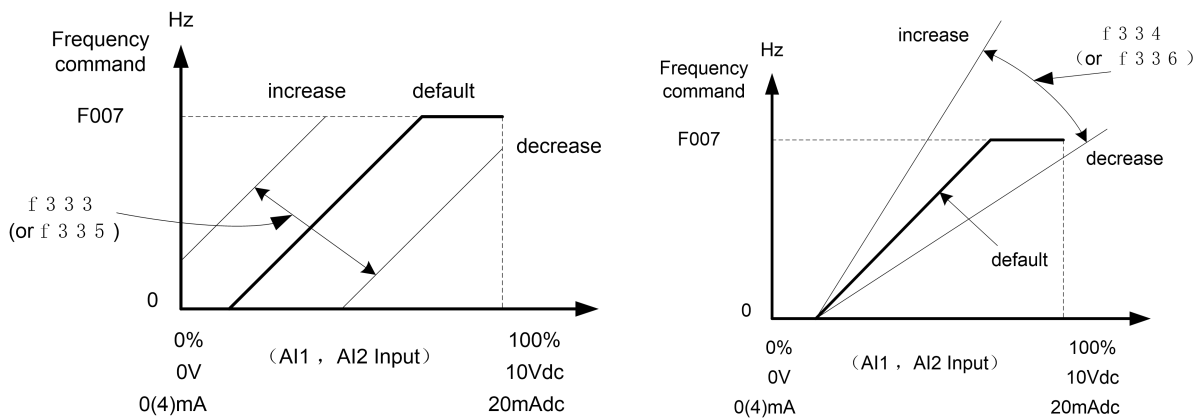

Figure 6.12 Calibration of analog input

Note 1: If you want to reduce the leeway, set f470 or f472 to a larger value. Note that specifying a too large value may cause an output frequency to be output, even though the operation frequency is 0 (zero) Hz.

Note 2: If you want to adjust the VFD so that it will output the maximum frequency at the maximum voltage and current input, set f471 or f473 to a smaller value. Note that specifying a too small value may cause the operation frequency not to reach the maximum frequency, even though the maximum voltage and current input are applied.

NO.	Parameter Name	Setting Range	Default
f337	Low-speed signal output frequency	0.0 Hz ~f007	0.0

When the output frequency exceeds the setting of f337, an ON signal will be generated. This signal can be used as an electromagnetic brake excitation/release signal.

This signal can also be used as an operation signal when f337 is set to 0.0Hz, because an ON signal is put out if the output frequency exceeds 0.0Hz.

If the VFD is so set, the signal will be put out through the open collector OUT(LO-CLO) and RELAY output terminals.

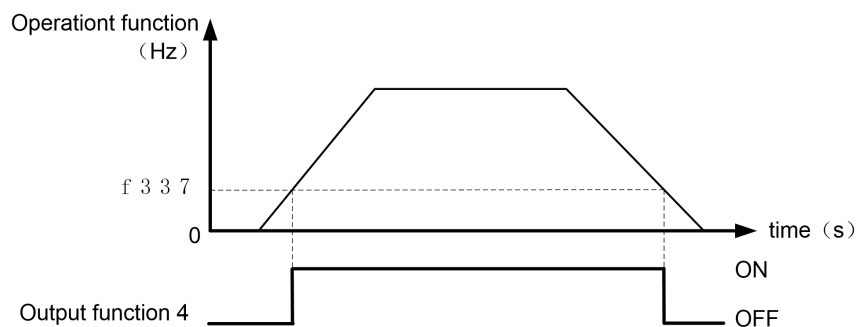

Figure 6.13 Description of Low-speed signal output frequency

NO.	Parameter Name	Setting Range	Default
f338	Speed reach detection output frequency	0.0 Hz ~f007	0.0
f339	Speed reach detection band	0.0 Hz ~f007	2.5

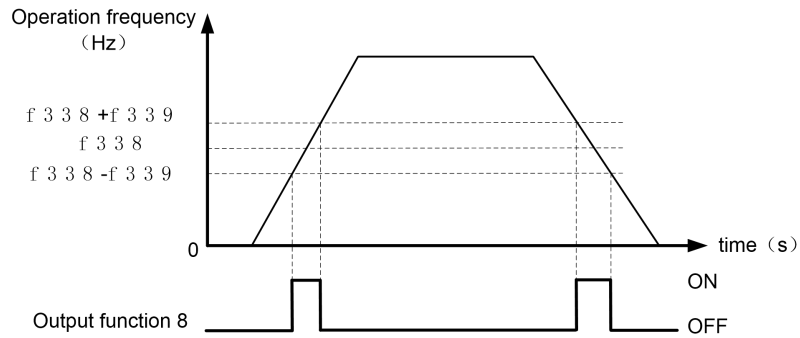

Figure 6.14 Description of Speed reach detection output frequency

NO.	Parameter Name	Setting Range	Default
f340	AI1 input reach detection level	0~100 %	0
f341	AI1 input reach detection band	0~20 %	3

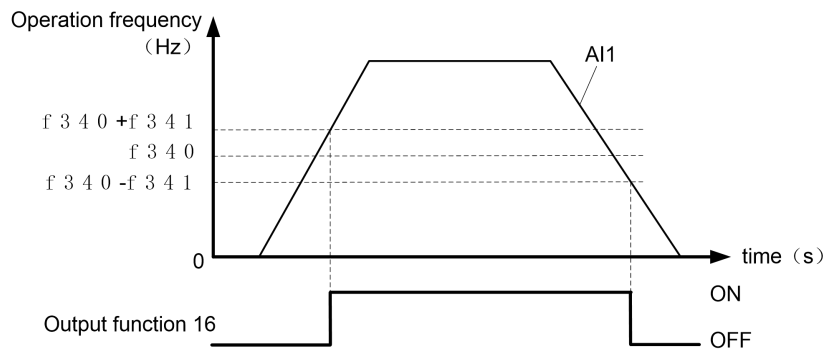

Figure 6.15 Description of AI1 input reach output

NO.	Parameter Name	Setting Range	Default
f342	AI2 input reach detection level	0~100 %	0
f343	AI2 input reach detection band	0~20 %	3

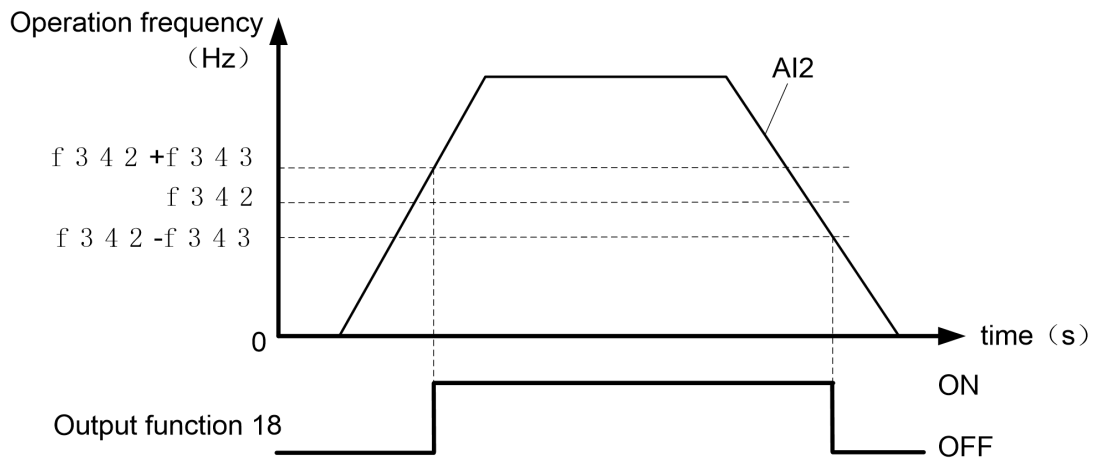

Figure 6.16 Description of AI2 input reach output

NO.	Parameter Name	Setting Range	Default
f344	Frequency command agreement detection range	0.0 Hz ~f007	2.5

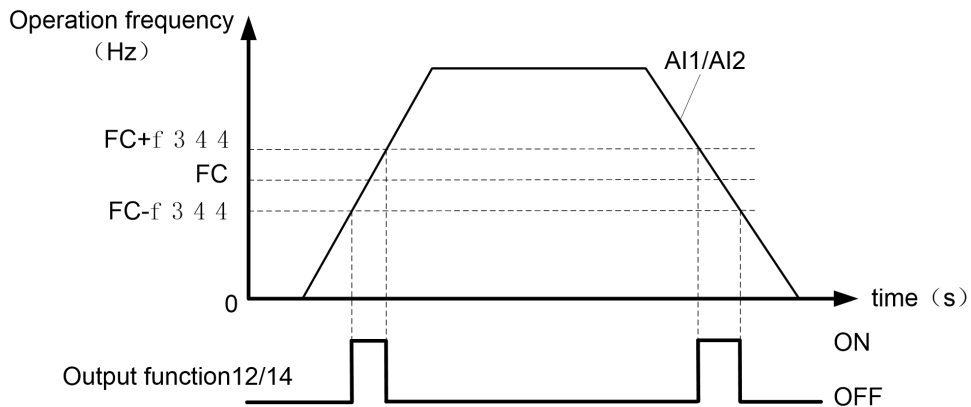

Figure 6.17 Description Frequency command agreement detection output

If the frequency command value specified using f003 (or f005) almost agrees with the frequency command value from the VA and VIB terminal with an accuracy of  $\pm f344$ , an ON or OFF signal will be sent out.

Note: This function can be used, for example, to send out a signal indicating whether the amount of processing and the amount of feedback agree with each other when the PID function is in use. For an explanation of the PID function.

NO.	Parameter Name	Setting Range	Default
f345	Logic output/pulse train output selection (LO1-CLO1)	0~1	0

0: Logic output    1: Pulse train output

NO.	Parameter Name	Setting Range	Default
f346	Pulse train output function selection (LO1 –CLO1)	0~14	0

Table6.4 Pulse train output function selection

f346	Description	Reference of max. value
0	Output frequency	f007
1	Output current	185% of VFD rated current
2	Set frequency (Before PID)	f007
3	Frequency setting value (After PID)	f007
4	DC voltage	150% of VFD rated voltage
5	Output voltage command value	150% of VFD rated voltage
6	Input power	185% of VFD capacity
7	Output power	185% of VFD capacity
8	AI1 Input value	5V /10V/20mA
9	AI2 Input value	10V
10	Torque	250% of motor rated torque
11	Torque current	250% of motor rated torque current
12	Motor cumulative load factor	100%
13	VFD cumulative load factor	100%
14	PBR (braking reactor) cumulative load factor	100%

Note : When item of f346 reaches "Reference of max. value", the number of pulse train set by f346 are sent to output terminals (LO1-CLO1).

NO.	Parameter Name	Setting Range	Default
f347	Maximum numbers of pulse train	500~1600	800

Note: The ON pulse width is maintained constant. The ON pulse width is fixed at a width that causes the duty to reach 50% at the maximum pulse number set with f347. Therefore, the duty is variable. For example, the ON pulse width is approximately 0.6 ms when f347 = 800, approximately 0.5ms when f347=1000, or approximately 0.3 ms when f347 = 1600.

NO.	Parameter Name	Setting Range	Default
f348	AO1 selection	0~18	0

The signal of internal calculated value can output from the AO1 terminal. Analog voltage output signal is default. Switching to 0-20mA<sub>dc</sub> (4-20mA<sub>dc</sub>) output current can be made by setting f307 to 0.

Table 6.5 AO selection parameters

f348	Description	maximum value
0	Output frequency	Maximum frequency f007
1	Output current	185% of invter rated current
2	Set frequency (before PID)	Maximum frequency f007
3	Frequency setting value (after PID)	Maximum frequency f007
4	DC voltage	150% of VFD rated voltage

f348	Description	maximum value
5	Output voltage command value	150% of VFD rated voltage
6	Input power	185% of VFD rated voltage
7	Output power	185% of VFD rated voltage
8	AI1 input	(1023)
9	AI2 input	(1023)
10	Torque	250% of VFD rated torque
11	Torque current	250% of VFD rated torque current
12	Motor cumulative load factor	100%
13	VFD cumulative load factor	100%
14	brake resistor cumulative load factor	100%
15	Serial communication data	—
16	f374 = 0% ~ 185% corresponds to the range of AO	—
17	f374 = 0% ~ 185% corresponds to the range of AO	—
18	f374 = 0% ~ 185% corresponds to the range of AO	—

NO.	Parameter Name	Setting Range	Default
f349	Analog output voltage scaling (AO1)	1~1280	464
f350	Inclination characteristic of analog output	0~1	1
f351	Bias of analog output	0~100%	0

The analog output characteristic can be adjusted by using the parameter f349, f350 and f351, see figure 6.18.

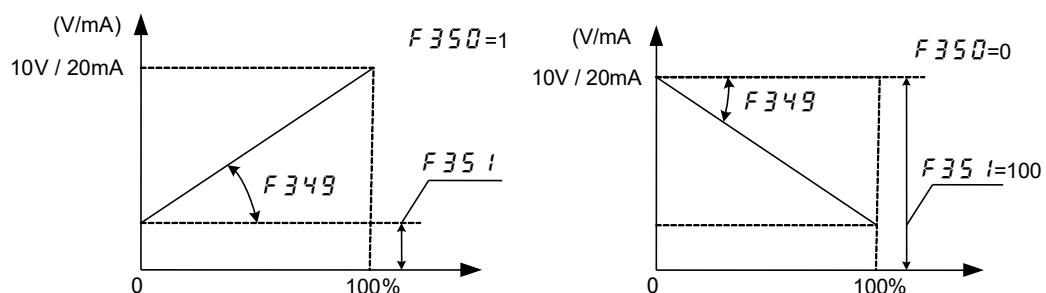

Figure 6.18 Description of f349, f350 and f351

Default output signals from AO1 terminals are analog voltage signals. Their standard setting range is from 0 to 10Vdc. Using these parameters, you can calibrate the output to 4-20mAdc or 20-4mAdc.

Note 1: To switch to 0-20mAdc (4-20mAdc) output, set f307 = 0.

Note 2: Only when f348 = 16, set value of f349 displays.

Note 3: When enters f349. operation frequency is displayed (f348 = 0), then press the ▲ key or the ▼ key to adjust f349. If a meter is connected to AO1, the meter reading will change at this time (f349 will change too) but be careful because there will be no change in the VFD 's digital LED (monitor) indication.

NO.	Parameter Name	Setting Range	Default
f352	output frequency when AO1 = 0V	0 Hz ~f007	0.0
f353	output frequency when AO1 = 10V	0 Hz ~f007	0.0

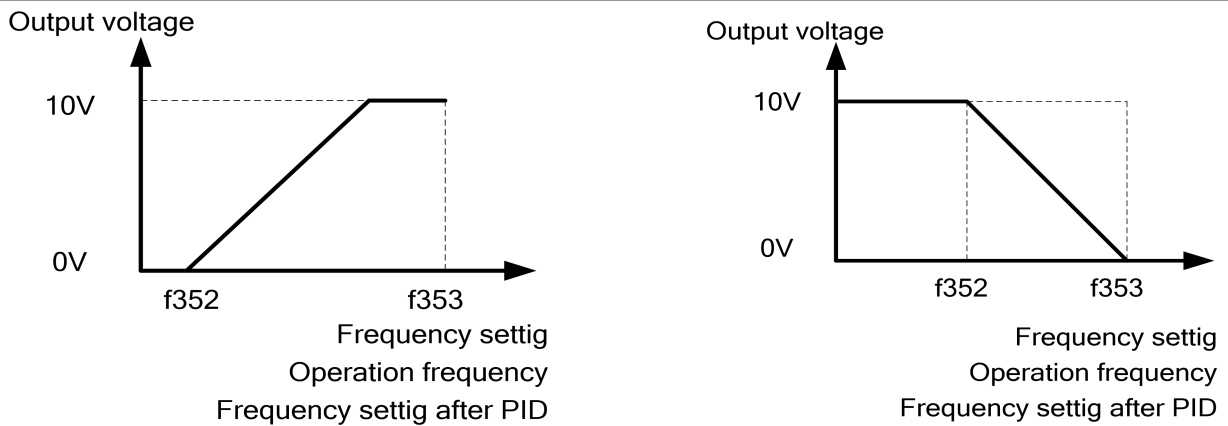

Figure 6.19 Description of f352 and f353 setting

Note: When f348 is set to 0 (or 2,3), if f352 or f353 are not set to 0 at same time, f350 and f351 will not be effective..

NO.	Parameter Name	Setting Range	Default
f354	Analog Output Voltage Bias Calibration (AO1)	0~255	126

For details of f354, see parameter f348.

Note: This parameter cannot be reset by f120 = 1.

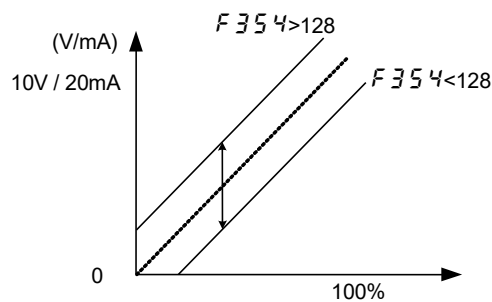

Figure 6.20 Description of f354

NO.	Parameter Name	Setting Range	Default
f355	Input terminal function for LI5	0~75	0
f356	Input terminal function for LI6	0~75	0
f357	Input terminal function for LI7	0~75	0
f358	Input terminal function for LI8	0~75	0

The set method is same as f301~f304.

Note1: Only valid when capacity rating is at 15kw or above.

NO.	Parameter Name	Setting Range	Default
f359	Main functions of Relay 2	0~255	0

NO.	Parameter Name	Setting Range	Default
f360	Relay 2 auxiliary functions	0~255	0
f361	Relay 2 main and secondary functional logic relationship	0~1	0
f362	Relay 2 closing delay time	0~60.0s	0.0

The set method is same as f315.

NO.	Parameter Name	Setting Range	Default
f363	Input terminal active mode	00~FF	00

This parameter is 8-bit binary-hexadecimal display (0x00~0xFF), and corresponds from right to left to the setting bits for LI1~LI8, with the setting options for each:

0: Input terminal function active when input terminal is OFF.

1: Input terminal function inactive when input terminal is ON.

NO.	Parameter Name	Setting Range	Default
f364	Input terminal filter time	0~200	0

A unit of filtering time constant 1 corresponds to 2ms.

NO.	Parameter Name	Setting Range	Default
f365	Output terminal function B of T1	0~ 69	0

The set method is same as f315.

NO.	Parameter Name	Setting Range	Default
f366	Output terminal logic selection of T1	0~1	0

The set method is same as f316.

0: With, f315 and f316 must satisfy the request at the same time, then relay one acts.

1: Or.f315 or 316 either satisfy the request, then relay one acts.

NO.	Parameter Name	Setting Range	Default
f367	Terminal run detection selection at power on	0~1	0

0: Disable, when power on, VFD will not supply to the motor even if the input terminal (to which forward/reverse run function is assigned) is ON, Only open the input terminal and re-close it will start the motor.

1: Enable. when power on, VFD will supply to the motor on the detection of the forward/reverse run terminal is ON.

NO.	Parameter Name	Setting Range	Default
f368	AO2 voltage-current output selection	0~1	0

0: Current signal output.

1: Voltage signal output.

NO.	Parameter Name	Setting Range	Default
f369	AO2 selection	0~16	0



NO.	Parameter Name	Setting Range	Default
f370	Analog output current scaling (AO2)	1~1280	375
f371	Inclination characteristic of analog output	0~1	1
f372	Bias of analog output	0~100%	0

The Settings of f369, f371 and f372 are shown in the corresponding parameters of AO1, f348, f350 and f351.

For detailed description of f370, see parameter f348.

Note: Parameter f370 cannot be reset by f120 = 1.

NO.	Parameter Name	Setting Range	Default
f373	Analog Output current Bias Calibration (AO2)	0~255	107
f374	Percentage of AO monitored values	0~250%	0

1) AO1-0 ~ 10V calibration is as follows:

f307 =1, f348 =18/17/16 Inverter stop state, set f374 =1%, adjust the value of f354, so that the actual output voltage is 0.1V. Then set f374 =100%/150%/185% and adjust the value of f349 to make the actual output voltage 10V.

After calibration is completed, f348 modifies back to the internal functional variables that need to be monitored.

2) Ao1-4 ~ 20mA calibration is as follows:

f307 =0, f351 =20%, f348=18/17/16 Inverter stop state, set f374 =0%, adjust the value of f432, make the actual output current is 4mA. Then set f374 =100%/150%/185% and adjust the value of f431 so that the actual output current is 20mA.

After calibration is completed, f348 modifies back to the internal functional variables that need to be monitored.

3) AO2-0 ~ 10V calibration is as follows:

f368 =1, f369 =18/17/16 Inverter stop state, set f374 =1%, adjust the value of f434, make the actual output voltage is 0.1V. Then set f374 =100%/150%/185% and adjust the value of f433 to make the actual output voltage 10V.

After calibration is completed, f369 modifies back to the internal functional variables that need to be monitored.

4) AO2-4 ~ 20mA calibration is as follows:

f368 =0, f372 =20%, f369=18/17/16 Inverter stop state, set f374 =0%, adjust the value of f373, make the actual output current is 4mA. Then set f374 =100%/150%/185% and adjust the value of f370 so that the actual output current is 20mA.

After calibration is completed, f369 modifies back to the internal functional variables that need to be monitored.

Note: Parameters f349 ~ f373 cannot be reset by f120 = 1.

NO.	Parameter Name	Setting Range	Default
f375	Output terminal logic selection of LO2-CLO2	0~1	0

0: f373 AND f374. The logical product (AND) of f373 and f374 will be output to LO2-CLO2.

1: f373 OR f374. The logical sum (OR) of f373 and f374 will be output to LO2-CLO2.

NO.	Parameter Name	Setting Range	Default
f376	LO2-CLO2 output delay	0~60.0 s	0.0

f376 specified the time of LO2-CLO2 output delay.

## 6.5. Fault protection parameter group

NO.	Parameter Name	Setting Range	Default
f400	Retry selection (Selecting the number of times)	0~10	0

0: disabled

1~10 times.

This parameter resets the VFD automatically when the VFD gives an alarm. During the retry mode, the motor speed search function operated automatically as required and thus allows smooth motor restarting.

Protective operation detection relay signals (T1A-T1B-T1C or T2A-T2B-T2C terminal signals) are not sent during use of the retry function.

To allow a signal to be sent to the protective action detection relay (TxA, B and C terminals) even during the retry process, assign the output terminal function 36 or 37 to f315.

A virtual cooling time is provided for overload tripping (e-21, e-22). In this case, the retry function will operate after the virtual cooling time and retry time.

In the event of tripping caused by an overvoltage (e-11), the retry function will not be activated until the voltage in the DC section comes down to a normal level.

In the event of tripping caused by overheating (e-24), the retry function will not be activated until the temperature in the VFD comes down low enough for it to restart operation.

Keep in mind that when f429 is set to 1 (trip retained), the retry function will not be performed, regardless of the setting of f400.

During retrying, the blinking display will alternate between a-08 and the monitor display specified by status monitor display mode selection parameter f610.

The number of retries will be cleared if the VFD is not tripped for the specified period of time after a successful retry. "A successful retry" means that the VFD output frequency reaches the command frequency without causing the VFD to re-trip.

Retry available fault including overcurrent (e-01, e-04), overvoltage (e-11), overheat (e-24), over load(e-21, e-22), and momentary power failure.

The retry function will be canceled at once if tripping is caused by an unusual event other than the retry available fault. This function will also be canceled if retrying is not successful within the specified number of times.

"Function be canceled" means VFD will be tripped and stop supply to motor.

The interval time is proportional relation with retry times. The first retry is 1sec, the second retry is 2 sec and the 10<sup>th</sup> retry is 10sec.

retry time	1	2	3	4	5	6	7	8	9	10
success time	1s	2s	3s	4s	5s	6s	7s	8s	9s	10s

Before all fault reset attempts are finished:

The output terminal to which output terminal function 40 (or 41) is assigned will not indicate the fault.

The output terminal to which output terminal function 38 (or 39) is assigned can be used to indicate the appearance of automatically retry available fault.

The output terminal to which output terminal function 30 (or 31) is assigned can be used to indicate any type of the fault in the VFD even if during the the period of retry.

NO.	Parameter Name	Setting Range	Default
f401	Electronic-thermal protection characteristic selection	0~7	0

Table 6.6 Description of f401

f401	motor type	overload tripped enable	overload stall
0	Standard motor	YES	NO
1		YES	YES
2		NO	NO
3		NO	YES
4	Special motor (forced cooling)	YES	NO
5		YES	YES
6		NO	NO
7		NO	YES

Overload stall: This is an optimum function for equipment such as fans, pumps and blowers with variable torque characteristics that the load current decreases as the operating speed decreases. When the VFD detects an overload, this function automatically lowers the output frequency before the motor overload trip e-21 is activated. This function operates a motor at frequencies that allow the load current to keep its balance so that the VFD can continue operation without being tripped.

Note: Do not use the overload stall function with loads having constant torque characteristics (such as conveyor belts in which load current is fixed with no relation to speed).

NO.	Parameter Name	Setting Range	Default
f402	Motor 150%-overload time limit	10~2400s	300

Parameter f403 is used to set the time elapsed before the motor trips under a load of 150% (overload trip e-22) within a range of 10 to 2400 seconds.

NO.	Parameter Name	Setting Range	Default
f403	Emergency stop selection	0~2	0
f404	emergency braking time	0~20.0 s	1.0

0: Free stop 1: Ramp stop

2: Emergency DC braking

These parameters allow you to specify how to stop operation using an external control device when an external trip occurs. When operation stopped, the trip e-43 displayed. When setting f403 =2 (emergency DC braking), set also f507 (DC braking rate) and f404 (emergency braking time). Assigning the trip stop function (input terminal function 11 or 27) to the contact input terminal.

Note 1: Emergency stopping via the specified terminal is possible, even during panel operation.

Note 2) If DC braking is not needed to bring the motor to a stop under normal conditions, although f403 is set to 2 (emergency DC braking), set the DC braking starting frequency (f506) at 0.0 Hz.

NO.	Parameter Name	Setting Range	Default
f405	Input phase failure detection	0~1	0

0: Disabled, No tripping.

1: Enabled, Phase failure detection is enabled during operation.

This parameter detects VFD input Phase failure. If the abnormal voltage status of main circuit capacitor persists for few minutes or more, the tripping function will be activated.

Therefore, input phase failures cannot always be detected. A trip information e-41 will be displayed. If the power capacity is larger than the VFD capacity (more than 200kVA or more than 10 times), detection errors may occur. If this actually happens, install an AC or DC reactor.

Note1: Setting f405 = 0(input phase failure detection: disabled) may result in a breakage of the capacitor in the VFD main circuit if operation is continued under a heavy load in spite of the occurrence of an input phase failure.

Note2: Parameter f405 is invalid for single-phase input model.

NO.	Parameter Name	Setting Range	Default
f406	Output phase failure detection mode selection	0~5	0

0: Disabled.

1: At start-up (Only one time after power is turned on).

2: At start-up (each time).

3: During operation.

4: At start-up and during operation.

5: Detection of cutoff on output side.

f406=0: No tripping.

f406=1: With the power on, the phase failure detection is enabled only at the start of the first operation. The VFD will trip if the Phase failure status persists for one second or more.

f406=2: The VFD checks for output phase failures each time it starts operation. The VFD will trip if the Phase failure status persists for one second or more.

f406=3: The VFD checks for output phase failures during operation. The VFD will trip if the Phase failure status persists for one second or more.

f406=4: The VFD checks for output phase failures at the start of and during operation. The VFD will trip if the Phase failure status persists for one second or more.

f406=5: If it detects an all-phase failure, it will restart on completion of reconnection. The VFD does not check for output phase failures when restarting after a momentary power failure.

Note1: A check for output phase failures is made during auto-tuning, regardless of the setting of this parameter.

Note2: Set f406=5 to open the motor-VFD connection by switching commercial power operation to VFD operation. Detection errors may occur for special motors such as high-speed motors.

NO.	Parameter Name	Setting Range	Default
f407	Small current trip/alarm selection	0~1	0

0: Alarm only. A small current alarm can be put out by setting the output terminal function selection parameter.

1: Tripping. The VFD will trip if a current below the current set with f408 flows for the period of time specified with f410. Trip information is displayed as "e-06".

NO.	Parameter Name	Setting Range	Default
f408	undercurrent detection current	0~100%	0.00
f409	under current detection current hysteresis	1~20%	10
f410	undercurrent detection time	0~255s	0

If a current smaller than the f408 specified value flows for more than the f410 specified time. When tripping is selected (see f407), enter the detection time to tripping. Trip information is displayed as "e-12". See figure 6.21.

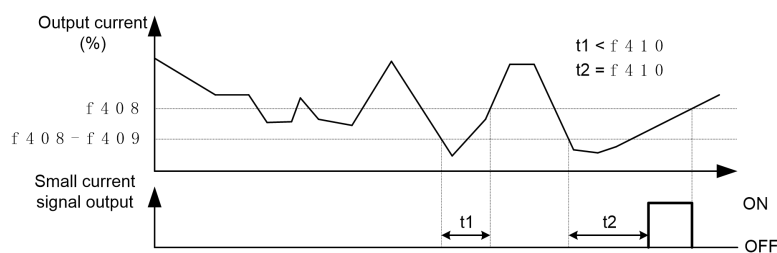

Figure 6.21 Description of small current

Note: The 100% standard value of f408 and f409 is the rated output current indicated on the motor nameplate.

NO.	Parameter Name	Setting Range	Default
f411	Over torque/over current indicator selection	0~5	0

0: Over-torque alarm: (70%)

- When the torque current reaches 70% of f412, the relay with function set as 48 will immediately operate;
- When the torque current reaches 100% of f412 and the duration reaches f414, the function is set as relay operation of 32;
- When the above relay (function is 48 or 32) operates, the panel will not operate and the converter will not stop.

1: Over-torque fault

- When the torque current reaches 70% of f412, the relay with function set as 48 will immediately operate, but the panel will not operate, and the converter will not stop;
- When the torque current reaches 100% of f412 and the duration reaches f414, the function is set as relay action of 32 and the converter reports the fault e-07;

2: Over-torque alarm: (100%)

- When the torque current reaches 100% of f412, the relay with function set as 48 will immediately operate;
- When the torque current reaches 100% of f412 and the duration reaches f414, the function is set as relay operation of 32;
- When the above relay (function is 48 or 32) operates, the panel will not operate and the converter will not stop.

3: Over-current alarm: (70%)

- When the output current reaches 70% of f412, the relay with function set as 48 will immediately operate;

- When the output current reaches 100% of f412 and the duration reaches f414, the function is set as relay operation of 32;
- When the above relay (function is 48 or 32) operates, the panel will not operate and the converter will not stop.

4: Overcurrent fault

- When the output current reaches 70% of f412, the relay with function set as 48 will immediately operate, but the panel will not operate, and the inverter will not stop;
- When the output current reaches 100% of f412 and the duration reaches f414, the function is set as relay action of 32 and the frequency converter reports the fault e-07;

5: Overcurrent alarm: (100%)

- When the output current reaches 100% of f412, the relay with function set as 48 will immediately operate;
- When the output current reaches 100% of f412 and the duration reaches f414, the function is set as relay operation of 32;
- When the above relay (function is 48 or 32) operates, the panel will not operate and the converter will not stop.

NO.	Working conditions		Operating conditions and operation of the converter
	Torque current	Output current	
1	f411=0	f411=3	No action on the panel, the inverter does not stop.
2	f411=1	f411=4	Torque/output current reached f412, and the duration reached f414, the panel reported failure e-07, the frequency converter stopped.
3	f411=2	f411=5	No action on the panel, the inverter does not stop.

NO.	Working conditions		Working conditions	
	Torque current	Torque current	Relay (Function 48)	Relay (Function 32)
1	f411=0	f411=3	When the torque/output current reaches 70% of f412, the relay operates immediately.  When the torque/output current reaches 100% of f412, the relay operates immediately.	The torque/output current reaches 100% of f412 and the duration reaches f414. The relay operates.
2	f411=1	f411=4		
3	f411=2	f411=5		

NO.	Parameter Name	Setting Range	Default
f412	Over-torque detection level	0~250%	130
f413	Over-torque detection level hysteresis	0~100%	10
f414	Over-torque detection time	0.0~10.0s	0.5

Use the f411 parameter to trip the VFD or to output the alarm if a torque current exceeding the f412-specified level flows for more than the f414-specified time. Trip information is displayed as "e-07".

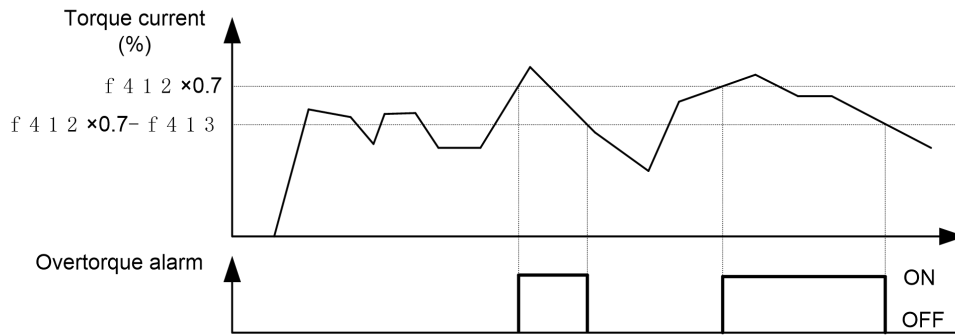

a) Over-torque detection alarm output

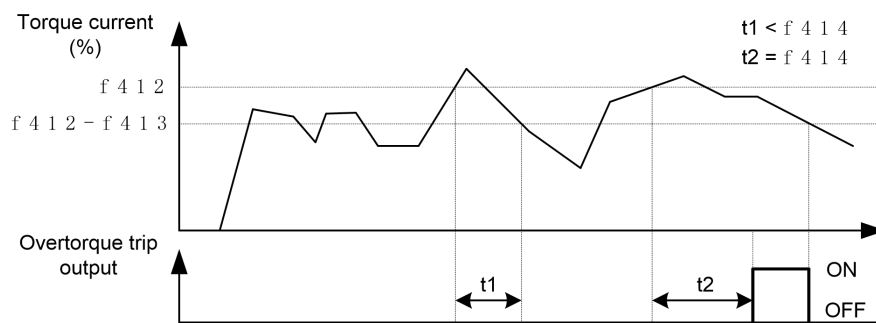

b) Over-torque detection trip output

Figure 6.22 Description of Over-torque detection

Note 1: Output over-torque detection alarm by assigning the output terminal function 48 to T1 (T2、LO1-CLO1 or LO2-CLO2). Output over-torque detection trip by assigning the output terminal function 32 to T1 (T2、LO1-CLO1 or LO2-CLO2).

Note 2: The 100% standard value of f412 and f413 is the rated output current indicated on the motor nameplate.

NO.	Parameter Name	Setting Range	Default
f415	Overvoltage limit operation	0~3	2

0: Enabled. When the VFD detects the upcoming overvoltage fault, it takes one of the following measures to avoid overvoltage: to increase deceleration time, to keep motor speed or raise motor speed.

1: Disabled

2: Enabled (Quick deceleration). The VFD will increase the voltage to the motor (over-excitation control) to increase the amount of energy consumed by the motor when the voltage reaches the overvoltage protection level, and therefore the motor can be decelerated more quickly than normal deceleration.

3: Enabled (Dynamic quick deceleration). the VFD will increase the voltage to the motor(over-excitation control) to increase the amount of energy consumed by the motor as soon as the motor begins to slow down, and therefore the motor can be decelerated still more quickly than quick deceleration.

Note: When motor speed falls, the VFD absorbs regenerative energy from the load and the motor. This often brings DC bus overvoltage fault. If f415 is set to 3, this portion of energy will not be fed back to the VFD, but converted to heat dissipation into the motor. In this case the motor intensely gives out heat.

NO.	Parameter Name	Setting Range	Default
f416	Overvoltage limit operation level	100~150%	130

f416 specifies the Overvoltage limit operation level.

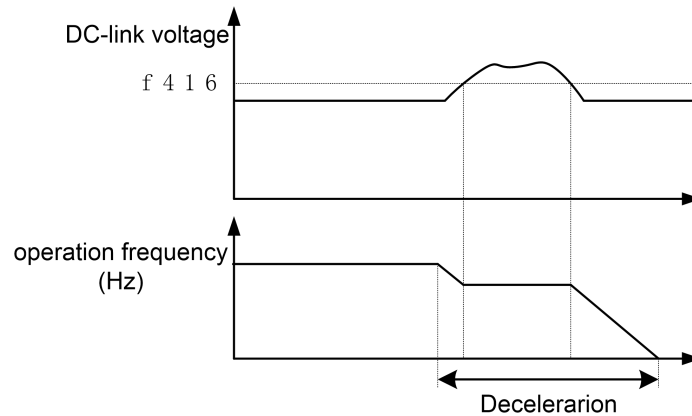

Figure6.23 Description of overvoltage limit operation level

NO.	Parameter Name	Setting Range	Default
f417	Undervoltage trip/alarm selection	0~2	0

0: Alarm only (detection level below 60%), The VFD is stopped. However, it is not tripped.

1: Tripping (detection level below 60%). VFD is stopped. It is also tripped

2: Alarm only (detection level below 50%, input reactor needed)

NO.	Parameter Name	Setting Range	Default
f418	Instantaneous power failure coast stop selection	0~2	0

0: disabled

1: factory reserved

2: Coast stop.

Coast stop in the event of momentary power failure: If a momentary power failure occurs during operation, the VFD coast stops forcibly. When operation is stopped, the message “a-06” is displayed (alternately) on the keypad. After the forced coast stop, the VFD remains static until you put off the operation command momentarily.

NO.	Parameter Name	Setting Range	Default
f419	Forced fire-speed control function	0~1	0

0: Disabled.

1: Enabled.

To enable forced speed mode, set f419 to 1, and allocate input terminal function 33 to a input contact terminal. If f419 is set to 1 and input terminal function 33 is ON, the VFD will run at the frequency set by f730. At this time, Put OFF the input terminal function 33 will not stop the VFD .

The following VFD trip will not make it stop, but automatic restart is performed.: e-01 , e-04, e-11 , e-21, e-22, e-23, e-24.

When the VFD is under local running mode, the VFD can only be stopped by powering off.

Note 1: The motor running direction is forward and the VFD runs according to the frequency command of the setpoint of f730.



Note 2: The following operations will not make the VFD or motor stop: disabling function 33, press STOP key or light trip occurs.

NO.	Parameter Name	Setting Range	Default
f420	Detection of output short-circuit during start-up	0~3	0

0: Each time (standard pulse)

1: Only one time after power is turned on (standard pulse)

2: Each time (short-time pulse)

3: Only one time after power is turned on (short-time pulse)

Note 1: when the phase resistor of the motor is small (motor capacity is large, short-time pulse is recommended).

NO.	Parameter Name	Setting Range	Default
f421	Motor electric-thermal protection retention selection	0~1	0

0: disabled. If the VFD is turned on and off, its motor thermal state memory (used for overload computation) will be cleared.

1: Enabled. Even if the frequency inverter is turned off, the motor thermal state memory of the frequency inverter is still retained. If motor overload fault e-22 occurs in the VFD, the motor can be restarted only after a period of cooling time (computed by the VFD).

NO.	Parameter Name	Setting Range	Default
f422	AI1 input loss	0~100%	0

0: Disabled. The VFD will not monitor the signal state on the analog input terminal AI1.

1~100: Fault detection level. If signal on AI1 drops below the selected fault detection level and this low signal level lasts 300 ms or more, fault occurs in the inverter. The keyboard panel will display fault code e-38.

NO.	Parameter Name	Setting Range	Default
f423	Activation of the VFD during 4-20mA signal loss	0~4	0

0: No measures.

1: Coast stop.

2: switch to Fallback speed. To switch to fallback speed f424. The duration is as long as the fault life time and the running command is still valid.

3: Speed maintaining. To maintain the speed at the time when fault occurs in the VFD. The duration is as long as the fault life time and the running command is still valid.

4: Slowdown stop.

NO.	Parameter Name	Setting Range	Default
f424	Fallback speed	0.0 Hz ~F004	0.0

See f423 = 2.

NO.	Parameter Name	Setting Range	Default
f425	PTC thermal selection	0~2	0

0: Disabled

1: Enabled (trip mode), If the PTC probe triggers the signal of fault, the VFD enters into fault state and displays “e-25”.

2: Enabled (alarm mode), if the PTC probe triggers the signal of fault, the VFD will trigger fault signal and continues running.

This function is used to protect motor from overheating using the signal of PTC built-in motor. Setting f425 to 1 or 2 can convert control terminal AI2 to a PTC motor thermal probe input. The wiring is shown in the following figure.

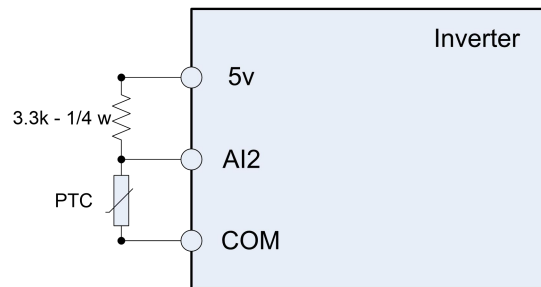

Figure 6.24 PTC wiring example

Note: PTC resistance must be connected in from AI2 terminal. One 3.3k-1/4 W resistance must be externally connected between 5 V and AI2.

NO.	Parameter Name	Setting Range	Default
f426	Resistor value for PTC detection	100~9999 Ω	3000

NO.	Parameter Name	Setting Range	Default
f428	Cumulative operation time alarm setting	0.0~999.9	610.0

This parameter allows you to set the VFD so that it will put out an alarm signal (Output terminal function = 50) after a lapse of the cumulative operation time set with f428.

Note: 0.1=10h.

NO.	Parameter Name	Setting Range	Default
f429	VFD trip retention selection	0~1	0

0: Clearing. The fault occurs and after the VFD is turned off and on,

If the fault cause has been eliminated, the inveter will be reset and can be started.

The information of just eliminated fault will be transmitted to the fault history record.

If the fault cause has not been eliminated yet, the fault will be displayed again and the running information related to the fault will be transmitted to the fault history record.

The information of the 4th from last fault will be eliminated from the fault history record.

1: Maintaining. The fault occurs and after the VFD is turned off and on,

If the fault cause has been eliminated, the inveter will be reset and can be started. The information of just eliminated fault will be transmitted to the fault history record.

If the fault cause has not been eliminated yet, original fault codes and all running data can be inquired as current fault under monitoring mode.

The information of the 4th from last fault will be reserved in the fault history record.

Automatic fault reset will be disabled.

NO.	Parameter Name	Setting Range	Default
f430	Heat sink temperature reaches the alarm value	0~100 °C	60

When the heat sink temperature reaches the setting value of f430, the VFD could output one alarm signal via logic output or relay output. Please refer to logic output function 66.

NO.	Parameter Name	Setting Range	Default
f431	Analog output current scaling (AO1)	1~1280	377

NO.	Parameter Name	Setting Range	Default
f432	Analog Output current Bias Calibration (AO1)	0~255	108

NO.	Parameter Name	Setting Range	Default
f432	Analog output voltage scaling (AO2)	1~1280	463

NO.	Parameter Name	Setting Range	Default
f434	Analog output voltage bias calibration (AO2)	0~255	126

See parameter f348 for detailed description of f431 ~f433.

Note: Parameters f431 ~ f433 cannot be reset by f120 = 1.

## 6.6. Fault protection parameter group

NO.	Parameter Name	Setting Range	Default
f500	Auto-restart control selection	0~4	0

0: Disabled

1: At auto-restart after momentary stop

2: When turning standby (input terminal function =1) on or off

3: At auto-restart or when turning standby (input terminal function =1) on or off

4: At start-up

5~7: factory reserved

8: First DC braking and then start. DC braking current level and braking time follow f507 and f508

The f500 parameter detects the rotating speed and rotational direction of the motor during coasting in the event of momentary power failure, and then after power has been restored, restarts the motor smoothly (motor speed search function).

This parameter also allows commercial power operation to be switched to VFD operation without stopping the motor. During operation, "a-08" is displayed. During the retry mode (see f400), the motor speed search function operated automatically as required and thus allows smooth motor restarting.

At restart, it takes about 300 ms for the VFD to check to see the number of revolutions of the motor. For this reason, the start-up takes more time than usual. Use this function when operating a system with one motor connected to one VFD. This function may not operate properly in a system configuration with multiple motors connected to one VFD.

Setting f500 =1, (3): This function operates after power has been restored following detection of an undervoltage by the main circuits and control power.

Setting f500 =2, (3): This function operates after the standby terminal((input terminal function =1) connection has been opened first and then connected again.

Setting f500 =4, a motor speed search is performed each time operation is started. This function is useful especially when the motor is not operated by the VFD but it is running because of external force.

Setting f500 = 0 (Disabled) and disabling the retry function (f400=0), when apply the VFD to crane or hoist. Such machines may have its load moved downward during the above waiting time from input of the operation starting command to the restart of the motor.

NO.	Parameter Name	Setting Range	Default
f501	auto-stop time limit for lower-limit frequency operation	0.0~600.0s	0.1

0: disabled (0.0) . None.

1: Enabled (0.1~600.0s) . If operation is carried out continuously at a frequency below the lower-limit frequency (f009) for the period of time set with f501, the VFD will enter into sleep mod and automatically slow down the motor to a stop. At that time, "a-10" is displayed (alternately) on the keypad. This function will be canceled if a frequency command above the lower-limit frequency (f009) +0.2Hz.

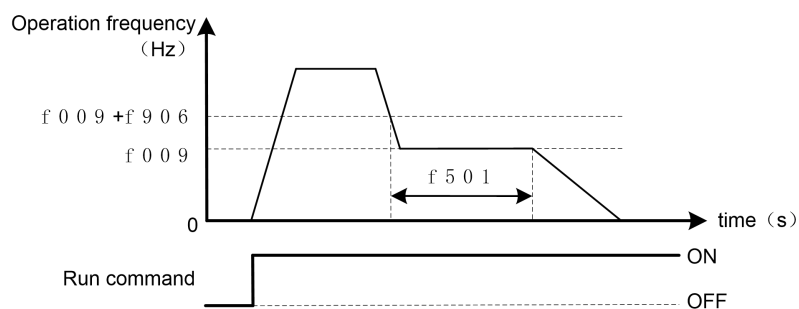

Figure 6.25 Description of sleep mode

Note: This function is enabled even at the start of operation and during switching between forward and reverse run.

NO.	Parameter Name	Setting Range	Default
f502	Bumpless operation selection	0~1	1

0: disabled.

1: enabled.

When switching from remote mode to local mode using f601, the status of start and stop, and operating frequency at remote mode are moved to local mode. By contraries, when switching from local mode to remote mode, they are not moved to remote mode.

Table 6.7 f502 description

f502 setting	switching between remote mode and local mode	description
0	Remote → Local	motor stops
	Local → Remote	run immediately with run command and frequency setting under remote control.
1	Remote → Local	motor runs continuesly with original run command and frequency setting under remote control.
	Local → Remote	run immediately with run command and frequency setting under remote control.

E.g, when f601=1, the VFD runs at 20 Hz of frequency setting under remote control mode. If switched to local mode (make f713=0), the VFD continues to run at 20 Hz under local control mode.

NO.	Parameter Name	Setting Range	Default
f503	Starting frequency setting	0.5~10.0Hz	0.5

The frequency set with f503 is put out as soon as operation is started. Use the f503 parameter when a delay in response of starting torque according to the acceleration/deceleration time is probably affecting operation. Setting the starting frequency to a value from 0.5 to 3Hz is recommended (f503 is usually set to the motor rated slip frequency). The occurrence of an overcurrent can be suppressed by setting this frequency below the rated slippage of the motor.

Rated slip frequency can be calculated with the parameters written on the nameplate of the motor:

$$f_s = f_0 - \frac{n_N * P}{60}$$

$P$  —— pole pairs.                       $n_N$  —— motor rated speed (rpm) .

$f_0$  —— base frequency (Hz) .       $f_s$  —— motor rated slip frequency (Hz) .

NO.	Parameter Name	Setting Range	Default
f504	Operation starting frequency	0.0 Hz ~f007	0.0
f505	Operation starting frequency hysteresis	0.0 Hz ~f007	0.0

The Run/stop of operation can be controlled simply with these two parameters. The VFD begins accelerating after the frequency setting signal has reached point B. Deceleration ends when the frequency setting signal decreases below point A.

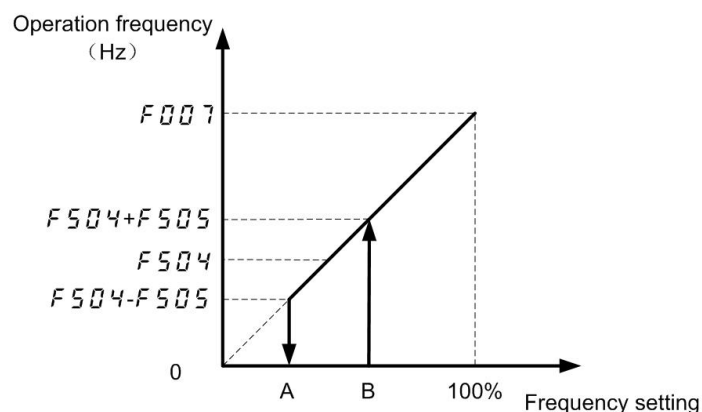

Figure 6.26 Description of Operation starting frequency

NO.	Parameter Name	Setting Range	Default
f506	DC braking starting frequency	0.0 Hz ~f007	0.0
f507	DC braking current	varies by model	varies by model
f508	DC braking time	0.0~20.0 s	1.0

A large braking torque can be obtained by applying a direct current to the motor. These parameters set the direct current to be applied to the motor, the application time and the starting frequency. During DC braking, a-07 displays.

DC braking can be activated by two methods as follows:

Auto matically DC braking: when operation frequency decreases below f506, DC braking is activated.

Input terminal signal: when the input terminal function 13 is ON, DC braking is activated.

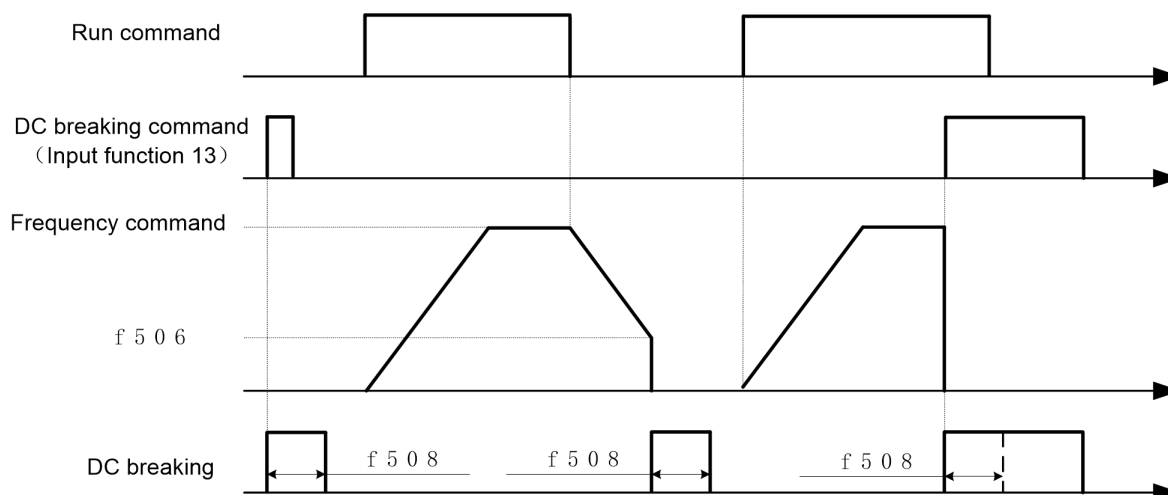

Figure 6.27 DC braking sequence

Note1: During DC braking, the overload protection sensitivity of the VFD increases. The DC braking current may be adjusted automatically to prevent tripping.

Note 2: During DC braking, the carrier frequency is 6 kHz or less irrespective of the setting of parameter f012 (PWM carrier frequency).

NO.	Parameter Name	Setting Range	Default
f510	Acceleration/deceleration 1 pattern	0~3	0

0: Linear, Linear, applied to most occasions.

- 1: S-type curve 1, for the need to minimize the slope time while minimizing the impact of the occasion.
- 2: S-curve 2, can be used for high-speed main Main axis where the acceleration needs to be reduced when the motor is running above its rated operating frequency (weak magnetic field, output electromagnetic torque decreases).
- 3: Elevator acceleration / deceleration curve.

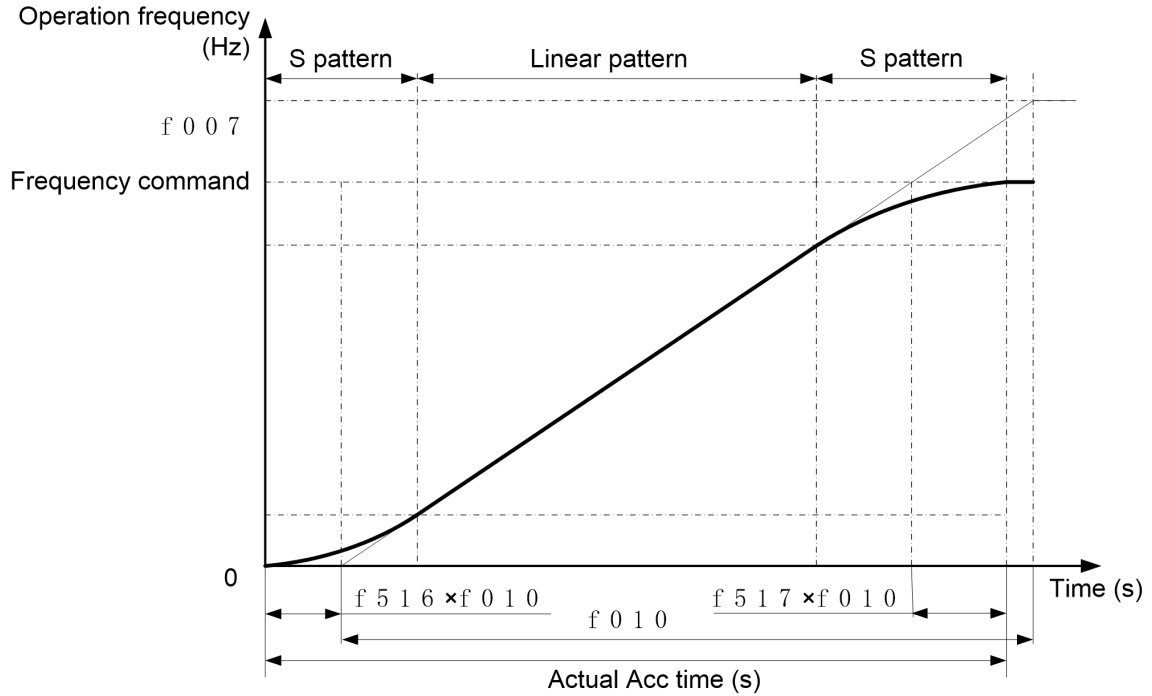

Figure 6.28 S-pattern acceleration/deceleration 1

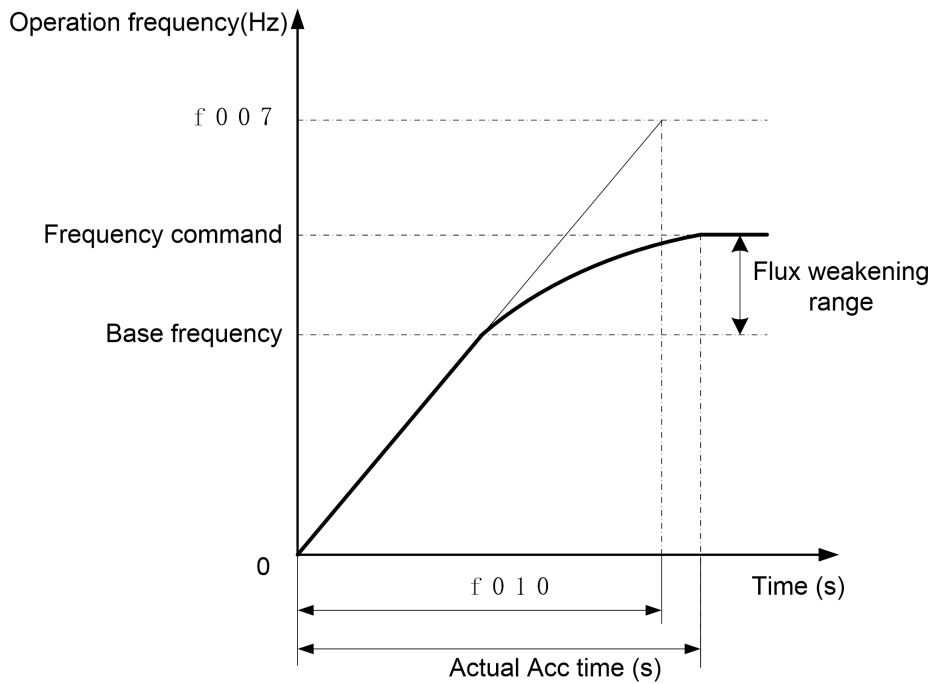

Figure 6.29 S-pattern acceleration/deceleration 2

LI1	LI4	LI3	LI2	Reference speed(frequency)selected	Acceleration/deceleration times
OFF	OFF	OFF	OFF	Speed 0 0.00Hz	f518
ON	OFF	OFF	OFF	Speed 1 (Run speed defined) defined by f003	f518
ON	OFF	OFF	ON	Speed 2 (Run speed defined) defined by f716	F010
ON	OFF	ON	OFF	Speed 3 (Maintenance speed ) defined by f717	f010/f011
ON	OFF	ON	ON	Speed 4 (Creep speed) defined by f718	f011
ON	ON	OFF	OFF	Speed 5 (Run speed defined) defined by f719	f518
ON	ON	OFF	ON	Speed 6 (Run speed defined) defined by f720	f010
ON	ON	ON	OFF	Speed 7 (Maintenance speed) defined by f721	f010/f011
ON	ON	ON	ON	Speed 8 (Creep speed) defined by f722	f011

Figure 6.30 Speed selection table

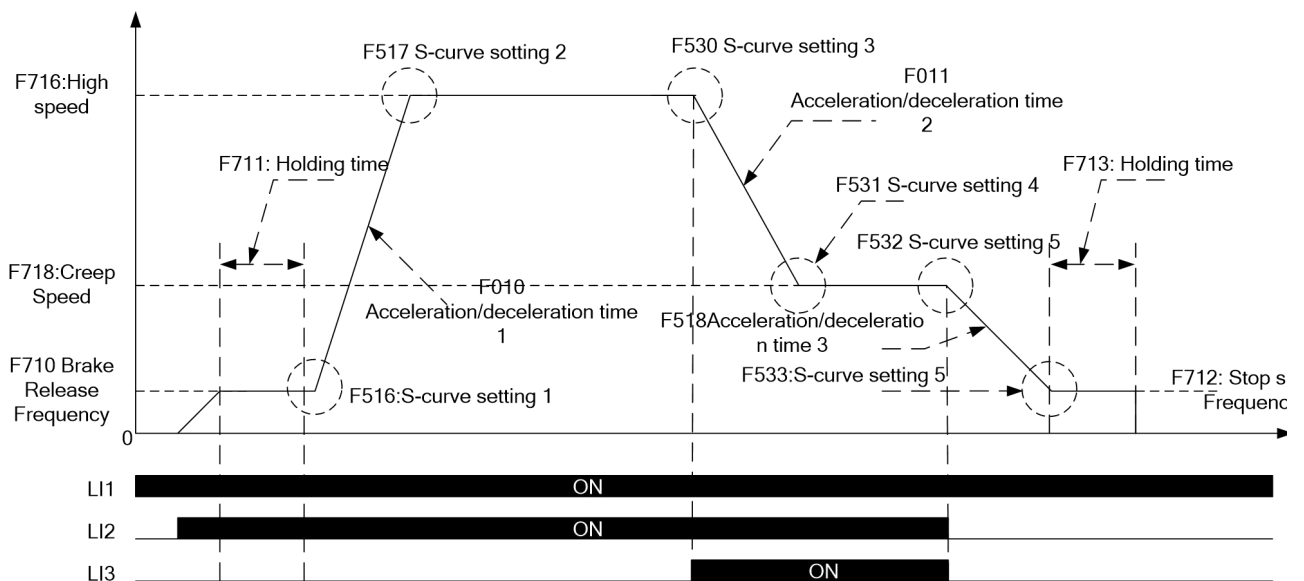

Figure 6.31 Elevator acceleration / deceleration curve

NO.	Parameter Name	Setting Range	Default
f511	Acceleration/deceleration 2 pattern	0~2	0
f512	Acceleration/deceleration 3 pattern	0~2	0
f513	Acceleration/deceleration 1 and 2 switching frequency	0.0 Hz ~f008	0.0
f514	Acceleration/deceleration 2 and 3 switching frequency	0.0 Hz ~f008	0.0



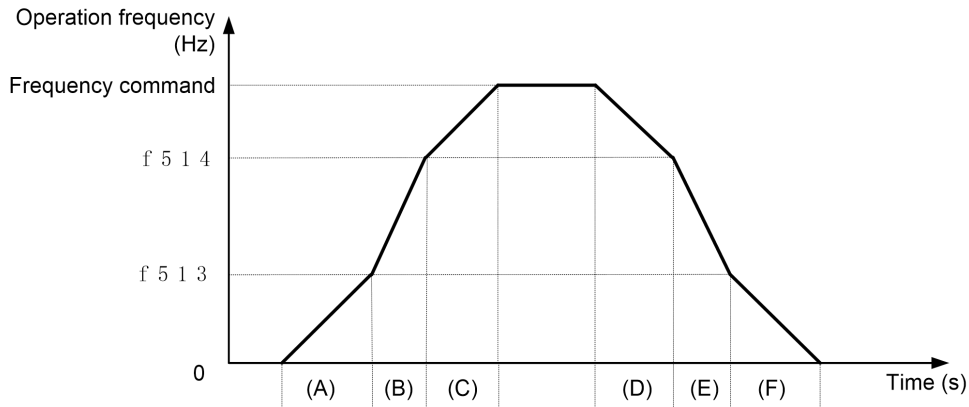

Figure 6.32 Acc/Dec parameters switching automatically

When set f513≠0 and the VFD output frequency increases above (or decreases below) f513 setting, f518(or f519) is effective.

Note:

(A) and (F) according to Acc/Dec 1; (B) and (E) according to Acc/Dec 2; (C) and (D) according to Acc/Dec 3.

NO.	Parameter Name	Setting Range	Default
f515	Selecting an acceleration/deceleration pattern	1~3	1

1: Acc/Dec 1, f010 , f011 and f510 are valid.

2: Acc/Dec 2, f518 , f519 and f511 are valid.

3: Acc/Dec 3, f520 , f521 and f012 are valid.

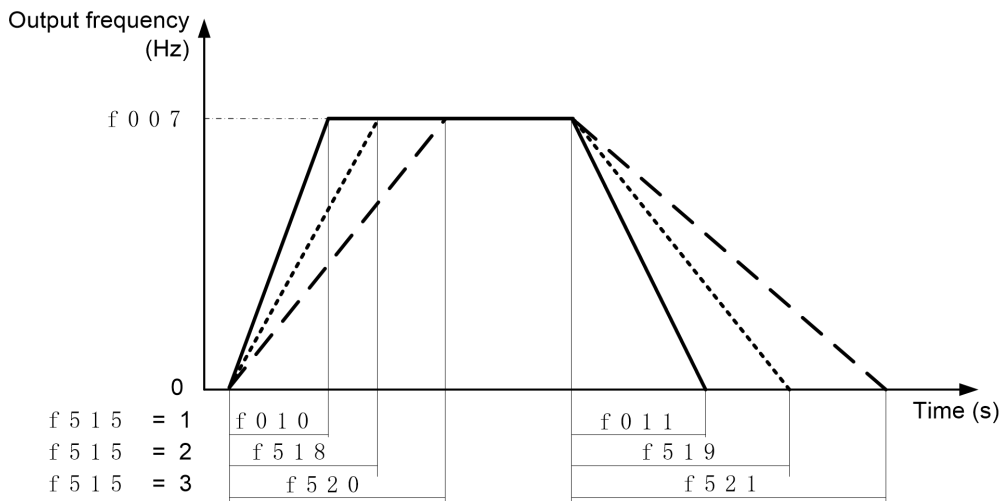

Figure 6.33 Acc/Dec parameters description

NO.	Parameter Name	Setting Range	Default
f516	S-pattern lower-limit adjustment amount	0~50 %	10
f517	S-pattern upper-limit adjustment amount	0~50 %	10

f516 and f517 are used to adjust the relative proportion of the upper arc and lower arc of the S curve against the complete acceleration/deceleration time.

NO.	Parameter Name	Setting Range	Default
f518	Acceleration time 2	0.0~3200s	20.0
f519	Deceleration time 2	0.0~3200s	20.0
f520	Acceleration time 3	0.0~3200s	20.0
f521	Deceleration time 3	0.0~3200s	20.0

Three acceleration times and three deceleration times can be specified individually. A method of selection or switching can be selected from among the following:

- 1) Selection by means of parameters, see f515
- 2) Switching by changing frequencies, see f513、f514
- 3) Switching by means of terminals, see input terminal function 5, 64.

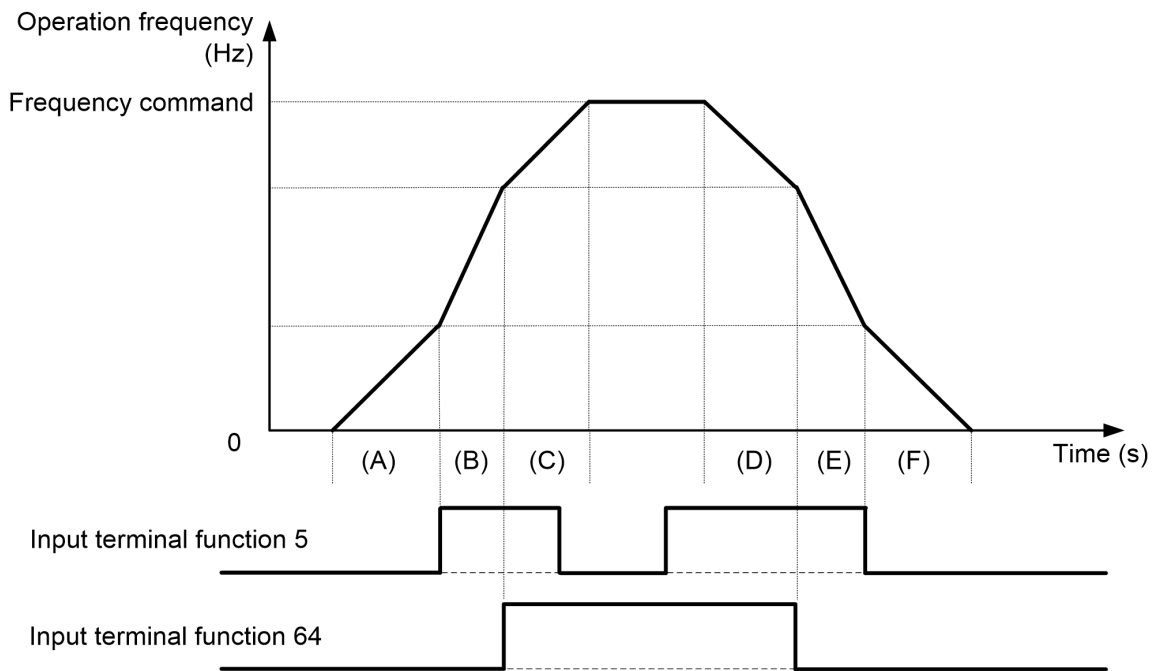

Figure 6.34 Using input contact terminal select Acc/Dec

Tabel 6.8 Using input contact terminal select Acc/Dec

input terminal function 64	input terminal function 5	Acc/Dec selection
0	0	Acc/Dec1
0	1	Acc/Dec 2
1	0	Acc/Dec 3
1	1	Acc/Dec 3

Tabel 6.9 Using input contact terminal and switching frequency select Acc/Dec

Frequency command	Input terminal function 5	Input terminal function 64	Acc/Dec selection
Fc =< f513	0	0	ACC1
	1	0	ACC2
	0	1	ACC1
	1	1	ACC2
f513 < Fc =< f514	0	0	ACC2
	1	0	ACC1
	0	1	ACC2
	1	1	ACC1
f514 < Fc	0	0	ACC3
	1	0	ACC3
	0	1	ACC3
	1	1	ACC3

Note:

(A) and (F) according to Acc/Dec 1; (B) and (E) according to Acc/Dec 2; (C) and (D) according to Acc/Dec 3.

NO.	Parameter Name	Setting Range	Default
f522	Reverse-run prohibition	0~2	0

0: Forward/reverse run permitted.

1: Reverse run prohibited.

2: Forward run prohibited.

NO.	Parameter Name	Setting Range	Default
f523	stop pattern	0~3	2

0: Ramp stops. If f506 ~ f508 is set effectively, the inverter will perform DC braking.

1: The keyboard stops freely. When the command channel is the keyboard panel, the motor stops freely.

2: Free stop is controlled by wire 2. When the operation command is controlled by wire 2 at terminal 2, the motor will be stopped freely.

3: Free stop of wire control; free stop of motor when the operation command is terminal 3 wire control.

Note 1: No matter whether the DC braking parameters are valid or not, the inverter cannot perform DC braking during free stop.

Note 2: As long as the setting of f523 is not free stop in the corresponding mode, the frequency converter will slow down and stop.

NO.	Parameter Name	Setting Range	Default
f526	Positive and negative operation is preferred	0~4	1

0: When positive and negative commands are given at the same time, the converter will run in reverse

- 1: The inverter stops when positive and negative commands are given at the same time
- 2: When the positive and negative commands are given at the same time, the inverter runs according to the commands given first.
- 3: When the positive and negative commands are given at the same time, the converter will run according to the commands given after both.
- 4: At the same time, the inverter runs as the forward and reverse rotation command.

NO.	Parameter Name	Setting Range	Default
f527	regenerative braking selection	0~2	2

0: Disabled

1: Enabled (with resistor overload protection)

2: Enabled (without resistor overload protection)

Connect an external braking resistor in the following cases to enable dynamic braking function:

- 1) When decelerating the motor abruptly or if overvoltage tripping (e-11) occurs during deceleration stop.
- 2) When a continuous regenerative status occurs during downward movement of a lift or the winding-out operation of a tension control machine.
- 3) When the load fluctuates and a continuous regenerative status results even during constant speed operation of a machine such as a press.

Note 1: To connect a dynamic braking resistor, set the overvoltage limit operation parameter f415 = 1(Disabled).

NO.	Parameter Name	Setting Range	Default
f528	regenerative braking resistance	1.0~1000.0 Ω	20.0
f529	regenerative braking resistor capacity	0.01~30.0 kw	0.12

NO.	Parameter Name	Setting Range	Default
f530	Positive and negative dead zone time	0.0~25.0s	0

f530 is only used for switching directions when running commands that are valid. The f530 setting is invalid if you first clear the run command and then change the direction of the run.

Note 1: When frequency is set by AI1 and f754 =1 (curve 2) :

(1) After the frequency converter receives the stop command and stops, if the given frequency is 0Hz, start first and then adjust the output frequency. No matter the given frequency is positive or reverse, start directly regardless of dead zone time;

(2) The direction of 0Hz is consistent forward, that is, before is positive rotation, and 0Hz is positive rotation; Before is reversal, 0Hz is reversal. Therefore, in the running process, after the given frequency changes to 0Hz and the motor stops rotating, if the frequency in the same direction is given again before the shutdown, the dead zone time is ignored and the motor starts directly. However, the final effect may be affected by the fluctuation of a given voltage when a potentiometer is used for a given frequency.

Note 2: f530 is also valid except when AI1 sets the frequency and f754 =1 (curve 2). But there are two caveats:

(1) f530 has no effect on inching at present. For example, when f002=0, f301 =2, f302 =19 and f526 =3 are set, the inverted inching is triggered by forward running of LI1, and then LI2 is closed at the same time. At this time,

the dead zone setting time of f530 is invalid, and there will be no pause at 0Hz when switching forward and backward.

(2) The direction of 0Hz is not kept consistent forward.

NO.	Parameter Name	Setting Range	Default
f531	Modbus protocol selection for HMI RS485 communication port	0~1	0

0: HMI RS485 communication port is the standard MODBUS protocol

1: HMI RS485 communication port is DisplayModBus protocol (select this protocol when using Chinese panel or Display)

NO.	Parameter Name	Setting Range	Default
f532	Acceleration / deceleration S - curve lower limit 3	0~50 %	10
f533	Acceleration / deceleration S - curve upper limit 3	0~50 %	10

f530/f532, f531/f533 similar to f516 and f517 used to modify the relative proportions of upper and lower arcs of the S-curve to the entire acceleration / deceleration time.

## 6.7. Keyboard panel parameter group

NO.	Parameter Name	Setting Range	Default
f600	Prohibition of panel reset operation	0~1	0

0: Permitted

1: Prohibited

This parameter can prohibited/ permitted the reset operation by <STOP> key.

NO.	Parameter Name	Setting Range	Default
f601	Switching between remote control and Local control	0~2	1

0: Local control mode, Start and stop, and frequency setting are effective only by keypad keys. f002~f005 is invalid.

1: remote control mode, Start and stop, and frequency setting follow the selection of f002, f003.

2. JOG key function is set in coordination with f700. See parameter f700 for details.

Note: When f700 =0, and f601 =0/2, JOG key is for local/remote switching function, setting of f601 is invalid, JOG key action shall prevail, see parameter f700 for details.

NO.	Parameter Name	Setting Range	Default
f602	Password check/input	0~9999	0

1. When f772 =0, the password protection function is invalid: no matter what f602 value is, any parameter can be modified;

2. When f772 ≠0, the password protection function takes effect:

(1) If f602 ≠f772, only the given frequency of f602 itself and the keyboard in the default state of power on can be modified;

(2) If f602 = f772, any parameter can be modified; However, after the time set by f773, f602 automatically reset to 0, and the protection parameter was modified. If you want to continue modifying the parameters, you need to enter the password again via f602.

3. When the password protection function is effective, if f602 ≠ f772, the value of f772 will be displayed as "---"; If f602 = f772, the normal password Settings are displayed when viewing the value of f772.

4. When the password protection function is effective and f602 = f772, if f773 = 0, f602 is always effective and will not reset automatically.

NO.	Parameter Name	Setting Range	Default
f603	Current/voltage display mode	0~1	1

0: %, display in percentage terms.

1: A (ampere)/V (volt), display in amperes/volts.

These parameters are used to change the unit of monitor display. Like current monitor and Voltage monitor display. (% ↔ A (ampere)/V (volt) )

Note1: f603 converts the following parameter settings: Motor electronic-thermal protection level 1 and 2 (f106, f110), DC braking current (f507), Stall prevention level 1 and 2 (f107, f111), Small current detection current (f408).

Note2: Base frequency voltage 1 and 2 (f102, f109) always displayed in the unit of V.

NO.	Parameter Name	Setting Range	Default
f604	Frequency free unit magnification	0.00~200.0	0.00

0.00: Free unit display disabled (display of frequency).

0.01-200.0: Value displayed = actual frequency [×] f604.

e.g., output frequency = 50Hz, if f604=30.0, Value displayed on the panel is 1500.

Note: This parameter displays the VFD output frequency as the value obtained by multiplying it by a positive number. This does not mean that the actual motor speed or line speed is indicated with accuracy.

NO.	Parameter Name	Setting Range	Default
f605	Factory reserved	0~1	0

NO.	Parameter Name	Setting Range	Default
f606	Inclination characteristic of free unit display	0~1	1

0: Negative inclination (downward slope)

1: Positive inclination (upward slope)

NO.	Parameter Name	Setting Range	Default
f607	Bias of free unit display	0.00Hz ~f007	0.00

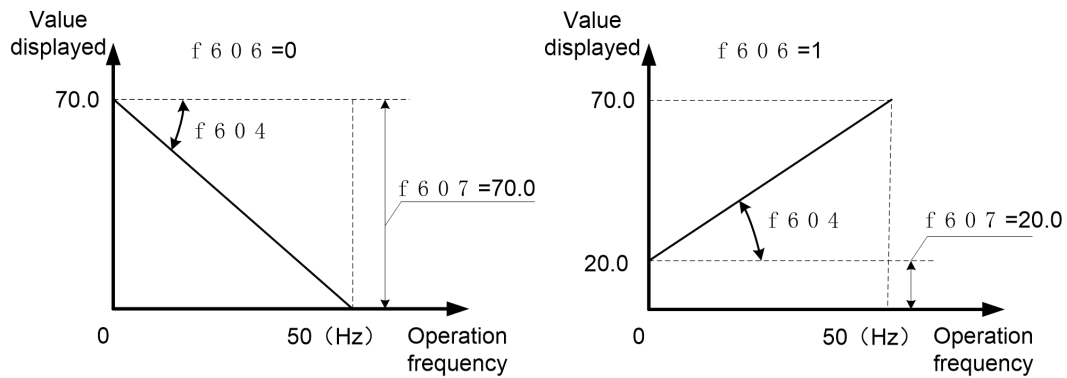

Figure 6.35 Description of freeunit

If f604 is not set as 0.00, value displayed is obtained as follows:

- When f606=0, value displayed = f604x (f607 – actual frequency value)
- When f606=1, value displayed = f604x (f607 + actual frequency value)

NO.	Parameter Name	Setting Range	Default
f608	Free step 1 (pressing a panel key once)	0.00 Hz ~f007	0.00

0.00: disabled.

0.01~f007: enabled.

Under normal conditions, the frequency command value from the keypad increases in steps of 0.1 Hz each time you press the ▲ key.

If f608 is not 0.00, the frequency command value will increase by the value with f608 each time you press the ▲ key. Similarly, it will decrease by the value set with f608 each time you press the ▼ key. In this case, the output frequency displayed in standard monitor mode changes in steps of 0.1 Hz, as usual.

The frequency (f000) set on the keypad changes in steps of 10.0 Hz: 0.0 → 20.0 → ... 50.0 (Hz), each time you press the ▲ key. This function comes in very handy when operating the load at limited frequencies that change in steps of 1Hz, 5Hz, 10Hz, and so on

NO.	Parameter Name	Setting Range	Default
f609	Free step 2 (panel display)	0~255	0

0: disabled.

1~255: enabled.

When f608 is not 0.00, and f609 is not 0 (disabled):

Output frequency displayed in standard monitor mode = Internal output frequency × f609÷f608.

Example: When f608 =1.00 (Hz), and f609 =1: Each time you press the ▲ key, the frequency setting changes in steps of 1Hz: 0→ 1 → 2 → ... → 50(Hz) and also the value displayed on the keypad changes in steps of 1. Use these settings to hide decimal fractions and also the value displayed on the keypad changes in steps of 1. Use these settings to hide decimal fractions.

The settings of f609 and f608 have no effect when the free unit selection (f604) is enabled.

NO.	Parameter Name	Setting Range	Default
f610	Standard monitor display selection	0~11	0

- 0: Output frequency (Hz(free))
- 1: Frequency command (Hz(free))
- 2: Output current(%/A)
- 3: VFD rated current (A)
- 4: VFD load (%)
- 5: Output power (kW)
- 6: Stator frequency (Hz (free))
- 7: Communication data display
- 8: Output speed
- 9: Communication counter
- 10: Normal communication counter
- 11: Stop - given frequency (f900 =0) /PID given (f900 ≠0), run - output frequency

Note: The parameter f610 determines the default value displayed on the first line of the keyboard panel when in power mode.

NO.	Parameter Name	Setting Range	Default
f611	Panel running order clear selection	0~1	1

0: Clear (when standby terminal OFF) . 1: Keep (when standby terminal OFF) .

Note 1: When f611=0, Put OFF the standby terminal (see input function 1) will stop the motor..

NO.	Parameter Name	Setting Range	Default
f612	Panel operation prohibition (F000)	0~1	0

0: Permitted 1: Prohibited

This parameter can prohibited/permitted set panel operation frequency(f000) by key ▲ and ▼.

NO.	Parameter Name	Setting Range	Default
f613	Prohibition of panel operation (RUN/STOP keys)	0~1	0

0: Permitted. 1: Prohibition.

NO.	Parameter Name	Setting Range	Default
f614	Prohibition of panel emergency stop operation	0~3	0

0: Permitted. 1: Prohibition.

2: No alarm during terminal emergency stop. In remote mode, the inverter can be stopped through the panel.

3: No alarm during terminal emergency stop. In remote mode, the inverter cannot be stopped through the panel.

NO.	Parameter Name	Setting Range	Default
f616	Integral output power retention selection	0~1	1

0: (clear), with the main power off, not retention of integral output power values.

1: (memory), with the main power off, retention of integral output power values.



NO.	Parameter Name	Setting Range	Default
f617	Integral output power display unit selection	0~3	varies by model

0: 1kWh. 1: 10kWh. 2: 100kWh. 3: 1000kWh.

NO.	Parameter Name	Setting Range	Default
f618	Search and resetting of changed parameters selection	0~1	0

0: Disable. Not display "-uf-" parameter group. 1: Enable. Display "-uf-" parameter group.

Users can automatically searches for those parameters that are programmed with values different from the standard default setting and displays them in the "-uf-" parameter group. Parameter setting can also be changed within this group.

NO.	Parameter Name	Setting Range	Default
f619	Frequency converter internal temperature monitoring		
f620	Frequency converter internal temperature monitoring		
NO.	Parameter Name	Setting Range	Default
f621	LCD contrast control	15-40	25
f622	Factory reserved		

NO.	Functional description		
f623	Additional function		
Bit	Description	0	1
0	The upper fan runs by itself	OFF	ON
1	Output positive power monitoring	OFF	ON
2-15	Factory reserved		

NO.	Parameter Name	Setting Range	Default
f624	Keyboard panel displays 2	Same as f610	2
	Quick Monitoring 1	Same as f610	
f625	Keyboard panel displays 3	Same as f610	1
	Quick Monitoring 2	1 ~ 8: see f610 9: PID is given 10: PID feedback	
f626	Keyboard panel displays 4	Same as f610	5
	Quick Monitoring 2	1 ~ 8: see f610 9: PID is given 10: PID feedback	

- Quick monitoring:

Fast monitoring is mainly used for LED panels (including: single LED, double LED).

In the default state of power-on, parameters set by f610, f624, f625 and f626 can be displayed by switching ENT button. (If it is a double LED panel, switch the display on the first row)

f624 has the same options as f610;

Options (1-8) of f625 and f626 are the same as those of f610. Option 9 is given PID and option 10 is PID feedback, as follows:

- 0: Motor working frequency (Hz or customized display).
- 1: Speed given (Hz or customized display). (marked with the letter F)
- 2: Motor current (% or A). (identified by letter C)
- 3: Rated current of frequency converter (A). (identified by letter C)
- 4: Frequency converter thermal state (%).
- 5: Output power (kW).
- 6: Internal speed given (Hz or custom display after PID function).
- 7: Serial communication data.
- 8: Output speed (RPM).
- 9: PID given pressure. (identified by letter G)
- 10: PID feedback pressure. (marked with letter B)

- Multi-line monitoring:

Multi-line monitoring is mainly used for LCD panels and double LED panels.

The parameter f624 determines the type of value displayed by default on the second line of the keyboard panel when in power-on mode.

The parameter f625 determines the type of value displayed by default on the third line of the keyboard panel when in power-on mode.

The parameter f626 determines the type of value displayed by default on the fourth row of the keyboard panel in power-on mode.

NO.	Parameter Name	Setting Range	Default
f627	Relay output -PID feedback check out	0.00~99.99	0.00
f628	Relay output -PID feedback to detect bandwidth	0.00~99.99	0.00

f627 and f628 mainly cooperate with relay function [84] to realize pressure reduction pump control;

f628 is also used in the relay function [86] to monitor the status of feedback pressure.

NO.	Parameter Name	Setting Range	Default
f629	Factory reserved	-	-

## 6.8. Additional function parameter group

NO.	Parameter Name	Setting Range	Default
f700	Panel JOG mode selection	0~1	0

JOG key for multifunctional reuse key, f700 and F601 can be set together to achieve the following functions: forward/reverse switch, local/remote switch, shortcut menu function (default), inching function.

NO.	f700	f601	JOG key function
1	0	0	Local/remote switching, power off to maintain; (Local sign: SET and MON lights on at the same time)
2	0	1	Non-function
3	0	2	Local/remote switching, power outage recovery default Settings; (Local sign: SET and MON lights on at the same time)
4	1	0 / 1 / 2	Ching function
5	2	0 / 1 / 2	Shortcut Menu 1
6	3	0 / 1 / 2	Shortcut Menu 2
7	4	0 / 1 / 2	Shortcut Menu 3
8	5	0 / 1 / 2	Same as f700=4.
9	6	0 / 1 / 2	Positive and negative switching (no LED identification)

Note: When JOG key is for local/remote switching function, the setting of f601 is invalid, and JOG key action shall prevail.

NO.	Parameter Name	Setting Range	Default
f701	jog run frequency	0.0~20.0	5.0

NO.	Parameter Name	Setting Range	Default
f702	Jog stopping pattern	0~2	0

0: Slow down stop

1: coast stop

2: DC braking.

Use the jog run parameters to operate the motor in jog mode. Input of a jog run signal fenerates a jog run frequency output at once, irrespective of the designated acceleration time.

NO.	Parameter Name	Setting Range	Default
f703	Jump frequency 1	0.0 Hz ~f007	0.0

NO.	Parameter Name	Setting Range	Default
f704	Jumping width 1	0.0~30.0 Hz	0.0
f705	Jump frequency 2	0.0 Hz ~F007	0.0
f706	Jumping width 2	0.0~30.0 Hz	0.0
f707	Jump frequency 3	0.0 Hz ~f007	0.0
f708	Jumping width 3	0.0~30.0 Hz	0.0

Resonance due to the natural frequency of the mechanical system can be avoided by jumping the resonant frequency during operation. During jumping, hysteresis characteristics with respect to the jump frequency are given to the motor.

Do not set the jump parameters, if multiple jump frequency setting width overlapped.

During acceleration or deceleration, the jumping function is disabled for the operation frequency.

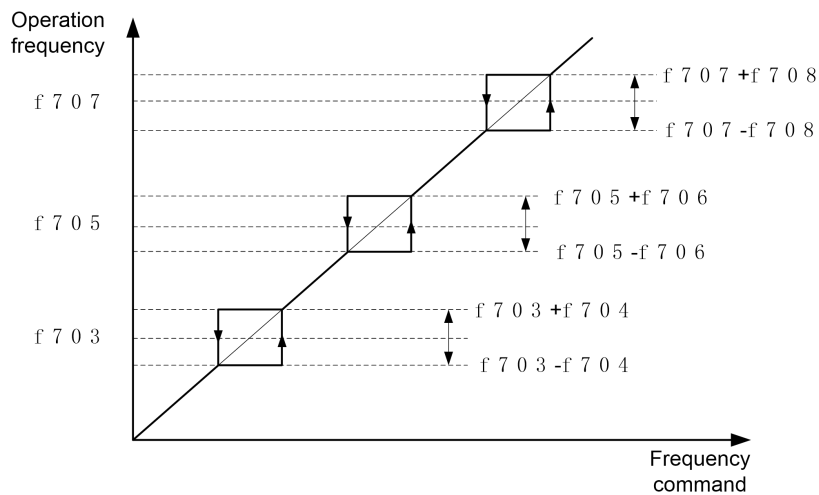

Figure 6.36 Description of jump frequency

NO.	Parameter Name	Setting Range	Default
f709	Braking mode selection	0 ~3	0

0: OFF

1: Forward direction

2: Reverse direction

3: Same set direction to f522

NO.	Parameter Name	Setting Range	Default
f710	Braking Release frequency	0.0~20.0 Hz	3.0
f711	Braking Release time	0.0 ~25.0s	0.5
f712	Braking Creeping frequency	0.0~20.0 Hz	3.0
f713	Braking Creeping time	0.0 ~25.0s	1.0

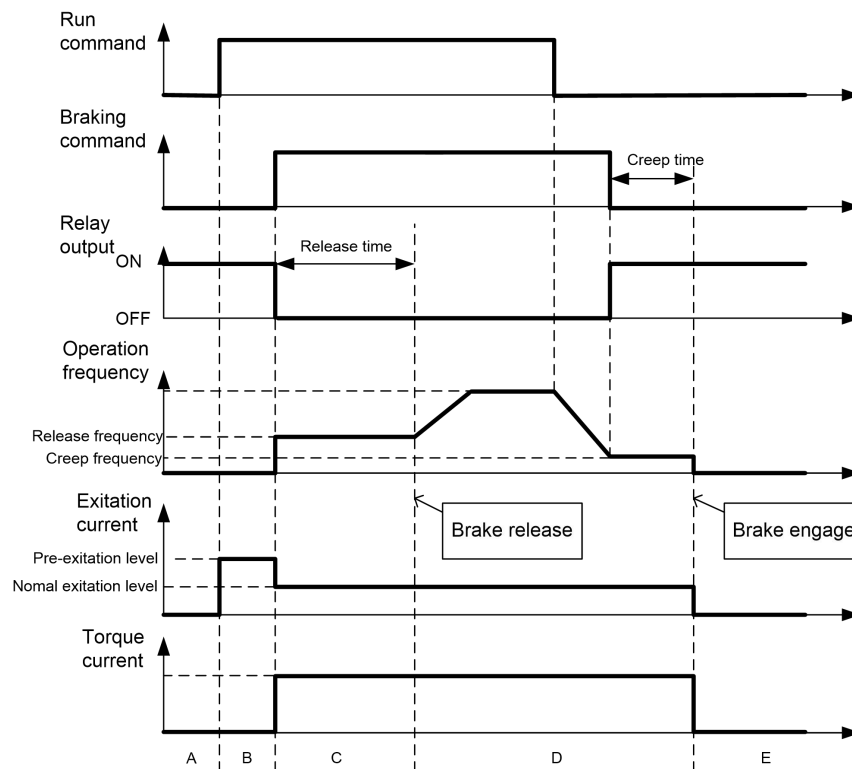

Figure 6.37 Description of braking mode sequence

NO.	Parameter Name	Setting Range	Default
f714	Droop control gain	0~100%	0
f715	Droop control insensitive torque band	0~100%	10

The droop control function refers to the function of operating the power-running motor at operating frequency F1 (Hz) that is lower than command frequency F0 (Hz) by droop frequency  $\Delta f$  (Hz) when the torque current is T1 (%). The droop frequency  $\Delta f$  can be calculated, using the following expression.

$$\text{Droop frequency } \Delta f \text{ (Hz)} = f_{101} \times f_{714} \times (\text{Torque current } T1 - f_{715})$$

When the torque current is above the specified droop insensitive torque band (f715), the frequency is reduced during power running or increased during regenerative braking.

The above figure shows an example of the operating frequency during power running. During regenerative braking, control is performed in such a way as to increase the frequency.

The droop function is activated above the torque current set with f715.

The amount of droop frequency  $\Delta f$  varies depending on the amount of torque current T1.

Note: If the base frequency exceeds 100Hz, count it as 100Hz. Control is exercised between the starting frequency (f503) and the maximum frequency (f007).

[An example of calculation]

Parameter setting: Base frequency  $f_{101}=60$  (Hz), droop gain  $f_{714}=10$  (%)

Droop insensitive torque band  $f_{715}=30$  (%)

Droop frequency  $\Delta f$  (Hz) and operating frequency F1 when command frequency F0 is 50 (Hz) and torque current T1 is 100 (%) are as follows.

Droop frequency  $\Delta f$  (Hz) =  $v_l \times f_{714} \times (T1 - f_{715})$

=  $60 \text{ (Hz)} \times 10 \text{ (%) } \times (100 \text{ (%) } - 30 \text{ (%)})$

= 4.2 (Hz)

Operation frequency  $F1$  (Hz) =  $F0 - \Delta f = 50 \text{ (Hz)} - 4.2 \text{ (Hz)} = 45.8 \text{ (Hz)}$

NO.	Parameter Name	Setting Range	Default
f716	Preset-speed 1	f009~f008	3.0
f717	Preset-speed 2	f009~f008	6.0
f718	Preset-speed 3	f009~f008	9.0
f719	Preset-speed 4	f009~f008	12.0
f720	Preset-speed 5	f009~f008	15.0
f721	Preset-speed 6	f009~f008	18.0
f722	Preset-speed 7	f009~f008	21.0
f723	Preset-speed 8	f009~f008	24.0
f724	Preset-speed 9	f009~f008	27.0
f725	Preset-speed 10	f009~f008	30.0
f726	Preset-speed 11	f009~f008	33.0
f727	Preset-speed 12	f009~f008	36.0
f728	Preset-speed 13	f009~f008	39.0
f729	Preset-speed 14	f009~f008	45.0
f730	Preset-speed 15	f009~f008	50.0

A maximum of 15 speed steps can be selected just by switching an external contact signal. Multi-speed frequencies can be programmed anywhere from the lower limit frequency f009 to the upper limit frequency f008.

Use the input terminal function selection to allocate “Preset-speed command 1” to “Preset-speed command 4” terminal. For more information, see table 6.8.

Table 6.8 Relation between Preset-speed command and Preset-speed

Setting Frequency	Preset-speed command 4	Preset-speed command 3	Preset-speed command 2	Preset-speed command 1
preset-speed commands are invalid	0	0	0	0
Preset-speed 1	0	0	0	1
Preset-speed 2	0	0	1	0
Preset-speed 3	0	0	1	1
Preset-speed 4	0	1	0	0
Preset-speed 5	0	1	0	1
Preset-speed 6	0	1	1	0

Setting Frequency	Preset-speed command 4	Preset-speed command 3	Preset-speed command 2	Preset-speed command 1
Preset-speed 7	0	1	1	1
Preset-speed 8	1	0	0	0
Preset-speed 9	1	0	0	1
Preset-speed 10	1	0	1	0
Preset-speed 11	1	0	1	1
Preset-speed 12	1	1	0	0
Preset-speed 13	1	1	0	1
Preset-speed 14	1	1	1	0
Preset-speed 15	1	1	1	1

NO.	Parameter Name	Setting Range	Default
f731	Factory reserved		
f732	Multi-speed 0 run time	0~6500.0s(min)	0.0
f733	Multi-speed 1 run time	0~6500.0s(min)	0.0
f734	Multi-speed 2 run time	0~6500.0s(min)	0.0
f735	Multi-speed 3 run time	0~6500.0s(min)	0.0
f736	Multi-speed 4 run time	0~6500.0s(min)	0.0
f737	Multi-speed 5 run time	0~6500.0s(min)	0.0
f738	Multi-speed 6 run time	0~6500.0s(min)	0.0
<i>F 739</i>	Multi-speed 7 run time	0~6500.0s(min)	0.0
<i>F 740</i>	Multi-speed 8 run time	0~6500.0s(min)	0.0
<i>F 741</i>	Multi-speed 9 run time	0~6500.0s(min)	0.0
<i>F 742</i>	Multi-speed 10 run time	0~6500.0s(min)	0.0
<i>F 743</i>	Multi-speed 11 run time	0~6500.0s(min)	0.0
<i>F 744</i>	Multi-speed 12 run time	0~6500.0s(min)	0.0
<i>F 745</i>	Multi-speed 13 run time	0~6500.0s(min)	0.0
<i>F 746</i>	Multi-speed 14 run time	0~6500.0s(min)	0.0
<i>F 747</i>	Multi-speed 15 run time	0~6500.0s(min)	0.0

Multi-step speed 0 means f000 setup value. when PLC is running

NO.	Name	Range	Default
<i>F 748</i>	PLC speed direction choice	0 ~65535	0

Setup method: Running direction follows the parameter, i.e. Turn 16bit Binary number into decimal system value.

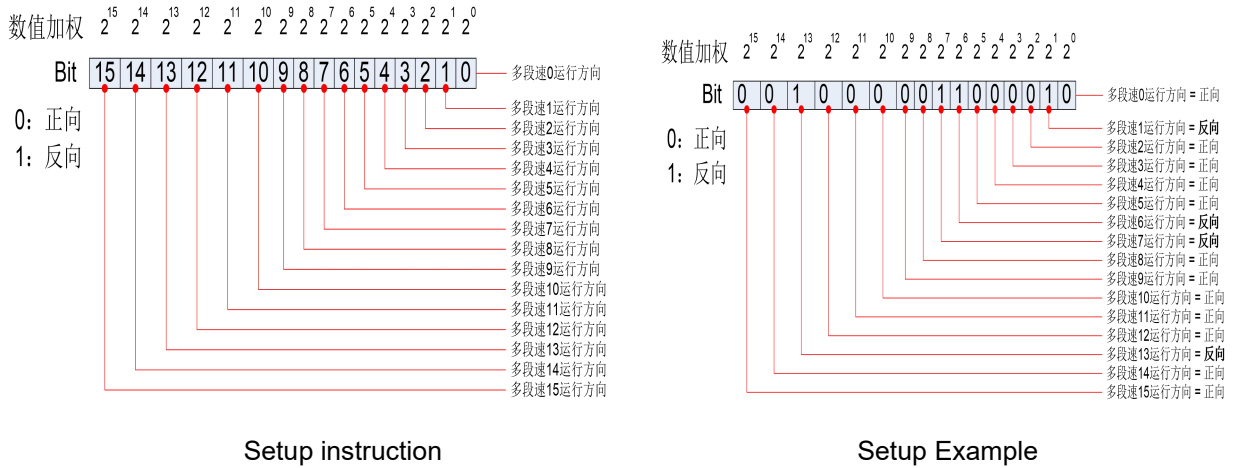

Parameter setup value

$$\begin{aligned}
 F\ 748 &= Bit15 * 2^{15} + Bit14 * 2^{14} + \dots + Bit1 * 2^1 + Bit0 * 2^0 \\
 &= 0 * 2^{15} + 0 * 2^{14} + 1 * 2^{13} + \dots + 1 * 2^7 + 1 * 2^6 + \dots + 1 * 2^1 + 0 * 2^0 \\
 &= 8192 + 128 + 64 + 2 = 8386
 \end{aligned}$$

Times square quick solution table

$$\begin{aligned}
 2^{15} &= 32768, \quad 2^{14} = 16384, \quad 2^{13} = 8192, \quad 2^{12} = 4096, \quad 2^{11} = 2048, \quad 2^{10} = 1024, \quad 2^9 = 512, \quad 2^8 = 256, \\
 2^7 &= 128, \quad 2^6 = 64, \quad 2^5 = 32, \quad 2^4 = 16, \quad 2^3 = 8, \quad 2^2 = 4, \quad 2^1 = 2, \quad 2^0 = 1
 \end{aligned}$$

NO.	Name	Range	Default
<b>F 749</b>	Simple PLC running mode choice	0 ~2	0

0: Stop after one-time running. The drive completes one cycling running and then automatically stop. Need one more running command to restart.

1: Run one time and keep final value running. The drive automatically keeps the final running frequency and direction after one single cycling running.

2: Cycling running. The drive will automatically come into next cycling after fulfilling one cycle until there is stop command.

Logic output function.

NO.	Name	Range	Default
<b>F 750</b>	Simple PLC restart mode choice	0 ~2	0

0: Run from the first paragraph. If the machine stops during operation (by stop command, fault), it will start from the first section after starting again.

1: Continue operation from the frequency of interruption time. If the machine stops during operation (by stop command, failure), the inverter will automatically record the running time of the current stage, and automatically enter this stage after starting again, and continue the operation of the remaining time at the frequency defined in this stage.



NO.	Name	Range	Default
<i>F 75 1</i>	Simple PLC power-off memory choice	0 ~1	0

0: Don't memorize power-off history. 1: Memorize power-off history.

PLC power-off memory means recording PLC running phase and running frequency before powering-off.

NO.	f750	f751	Power off state	Power up again, run time status
1	0	0	Downtime	Run from the first section of the PLC
			Running	Run from the first section of the PLC
2	1	0	Downtime	Run from the first section of the PLC
			Running	Run from the first section of the PLC
3	0	1	Downtime	Run from the first section of the PLC
			Running	Run from the time of power outage frequency
4	1	1	Downtime	Run from the down frequency
			Running	Run from the time of power outage frequency

NO.	Name	Range	Default
<i>F 75 2</i>	Simple PLC running time unit choice	0 ~1	0

0: Second (s)

1: Minute (min)

NO.	Name	Range	Default
<i>F 75 3</i>	Nonstandard function selection	0~65535	0

0: Standard features

1~65535: Non-standard functions.

Note 1: This parameter shall be effective if the frequency converter is switched on after power off.

Note 2: This parameter cannot be reset by f120 = 1.

NO.	Name	Range	Default
<i>F 75 4</i>	AI1 curve selection	0~1	0

0: Curve 1 (point 2, see f325 ~ f328)

1: Curve 2 (4 points, see f755 ~f762)

AI1 has two setting curves, which can be selected by parameter f754. Where curve 1 is a 2-point line and curve 2 is a 4-point curve (as shown in the figure below).

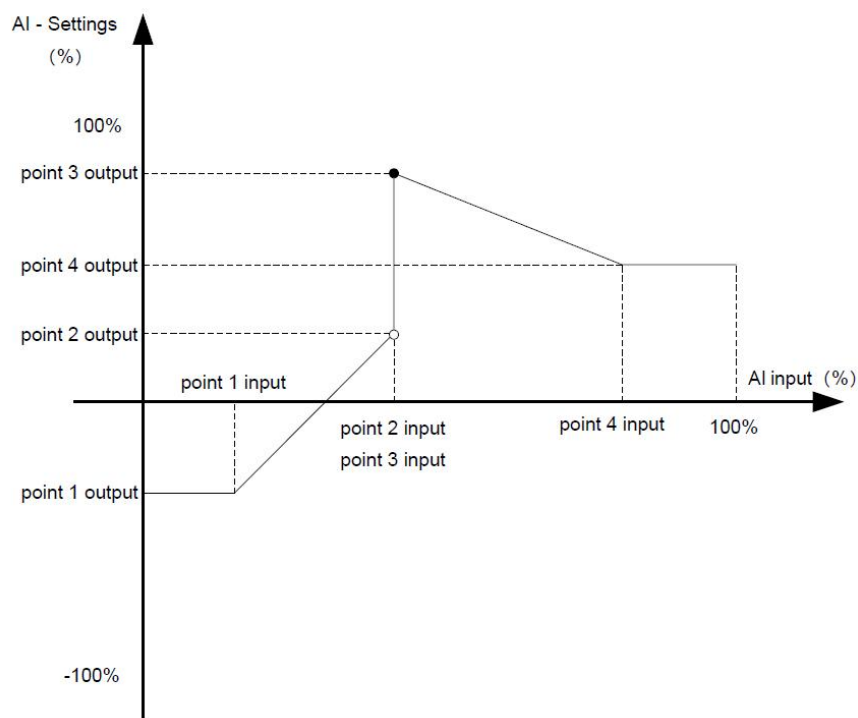

When the corresponding frequency of AI1 is set through the 4-point curve in the figure above:

(1) The frequency set by AI1 can be positive or negative. When is positive, the operation can be reversed; when is negative, the operation can be reversed. In addition, f530 can set the dead zone time during the forward reverse switch.

(2) When AI1 input < f755, the output frequency is f756;

When AI1 inputs > f761, the output frequency is f762.

(3) Step is allowed to occur at a given frequency of AI1.

NO.	Name	Range	Default
f755	AI1 curve 2 set point 1 input	0.0 ~ 100.0%	0.0%
f756	AI1 curve 2 sets point 1 output	-100% ~ 100%	0.0%
f757	AI1 curve 2 set point 2 input	0.0 ~ 100.0%	30.0%
f758	AI1 curve 2 sets point 2 output	-100% ~ 100%	30.0%
f759	AI1 curve 2 set point 3 input	0.0 ~ 100.0%	60.0%
f760	AI1 curve 2 sets point 3 output	-100% ~ 100%	60.0%
f761	AI1 curve 2 set point 4 input	0.0 ~ 100.0%	100.0%
f762	AI1 curve 2 sets point 4 output	-100% ~ 100%	100.0%
f763	LI1 effective delay	6500.0 ~ 0.0 s	0.0
f764	LI1 invalid delay	6500.0 ~ 0.0 s	0.0
f765	LI2 effective delay	6500.0 ~ 0.0 s	0.0
f766	LI2 invalid delay	6500.0 ~ 0.0 s	0.0
f767	AI1 filtering coefficient	0.00 -10.00	0.30
f768	AI2 filtering coefficient	0.00 -10.00	0.30
f769	AO1 filtering coefficient	0.00 -10.00	0.00

NO.	Name	Range	Default
f770	AO2 filtering coefficient	0.00 -10.00	0.00

Note: f767 and f768 are filtering coefficients of analog input AI1 and AI2. By increasing the value appropriately, the anti-interference ability of analog input can be enhanced, but its sensitivity will be weakened.

f769 and f770 are filter coefficients of ANALOG output AO1 and AO2. Increasing this value can enhance the stability of analog output, but weaken its sensitivity.

NO.	Name	Range	Default
<i>F 771</i>	Enable Reverse Jog frequency	0.0~20Hz	0.0

0: Reverse inching frequency is forbidden. At this time, press f701 for inching frequency, the inching acceleration time is 0.1s (not adjustable), and the deceleration time is f011.

0.1~20.0: enable reverse inching frequency. At this point, press f701 for inching frequency and f518 and f519 for inching deceleration time. For reverse inching, the inching frequency is f771, and the reverse inching acceleration and deceleration time is f520 and f521.

NO.	Name	Range	Default
<i>F 772</i>	Password Setting	0~9999	0
<i>F 773</i>	Password duration	0~9999	5

See parameter f602 for detailed description of f772 and f773.

## 6.9. Communication function parameter group

NO.	Parameter Name	Setting Range	Default
<i>F 800</i>	Modbus baud rate	0~1	1

0: 9600 bps. 1: 19200 bps. 2: 4800 bps. 3: 2400 bps. 4: 1200 bps.

Remarks: it only works after re-power on if we decide to modify *F 800*.

NO.	Parameter Name	Setting Range	Default
<i>F 801</i>	Modbus parity	1	1

0: NONE, datum format : < 8, N, 2 >. 1: EVEN, datum format : < 8, E, 2 >. 2: ODD, datum format : < 8, O, 2 >.

Remarks: it only works after re-power on if we decide to modify *F 801*.

NO.	Parameter Name	Setting Range	Default
<i>F 802</i>	Modbus address	0~247	1
<i>F 803</i>	Modbus timeout	0~100	0

0: timeout check disabled.

1-100: 1=1s.

NO.	Parameter Name	Setting Range	Default
<i>F 804</i>	Modbus transfer waiting time	0~2.00s	0.00

NO.	Parameter Name	Setting Range	Default
<i>F805</i>	Modbus behaviour on communication fault	0~4	4

0: VFD stop, communication command, frequency mode open(by *F002*, *F003*)

1: None (continued operation) 2: Deceleration stop 3: Coast stop

4: Communication error (*E - 33* trip) or Network error (*E - 35* trip)

NO.	Parameter Name	Setting Range	Default
f806	Number of motor poles for communication	1~8	2

The parameter setup will place the influence upon the display of u010.

NO.	Parameter Name	Setting Range	Default
f813	Module writes data 1	0~6	1
f814	Module writes data 2	0~6	3

0: Off

1: Communication command control (FA05)

2: Reservations

3: Communication frequency setting (FA08)

4 ~ 6: reservations

Note: (1) the setting of f813-f814 must be switched on after power off until the LED display is black.

(2) Block first address is 1813H (hexadecimal 1813).

NO.	Parameter Name	Setting Range	Default
<i>F815</i>	Module datas read 1	0~21	1
<i>F816</i>	Module datas read 2	0~21	2
<i>F817</i>	Module datas read 3	0~21	12
<i>F818</i>	Module datas read 4	0~21	18
<i>F819</i>	Module datas read 5	0~21	8

0: Off

1: Status Information (FD03)

2: Output frequency (FD12)

3: Output current (FE08)

4: Output voltage (FE10)

5: Fault information (FC39)

6: PID feedback value (FA36)

7: Input terminal information (FD01)

8: Output terminal information (FD02)

9: AI1 input (FE30)

10: AI2 input (FE31)

11: Motor speed (FE50)

- 12: Absolute value of output current (E002), unit 0.01a
- 13: Absolute value of output voltage (E006), unit V
- 14: Absolute value of input voltage of DC bus (E009), unit V
- 15: PID given value (FA35)
- 16: Output torque (FE20), 0.01% of rated torque per unit motor
- 17: Input power (FE28), 0.01kW
- 18: Output power (FE29), 0.01kW
- 19: Input power accumulation/input electric energy (FE44), the unit is determined according to the parameter f617
- 20: Output power accumulation/output electric energy (FE45), the unit is determined according to the parameter f617
- 21: Cumulative running time (FE17), unit h (hours)

Note: (1) the setting of f815-f819 must be switched on after power off until the LED display is black.

(2) Block first address 1815H (hexadecimal 1815)

(3) The range of the number of registers read is 2-5 (2-5).

NO.	Parameter Name	Setting Range	Default
f821	Factory reserved		
f822	Factory reserved		
f823	Factory reserved		
f824	Factory reserved		
f825	Factory reserved		
f826	Factory reserved		
f827	Factory reserved		
f828	Factory reserved		
f829	Factory reserved		

NO.	Parameter Name	Setting Range	Default
f830	PID setting of keypad	0~100%	0.0

f830=100% can make the sensor output the maximum value.

The 100% standard value of f830 is the measurement range of sensor. If the measurement range of pressure sensor is 0.0~1.6Mpa for example, set f830 =100% means that pressure setting is 1.6Mpa.

Note 1: When f900=0, f830 is not effective.

Note 2: f830 is completely corresponded to f916. When one has changed, the other will automatically updated.

## 6.10. Process PID parameter group

PID control is a common method used in process control. By carrying out proportional, integral and differential operations on the deviation between the feedback signal of the controlled quantity and the target quantity, the output frequency of the inverter can be adjusted to form a negative feedback system to stabilize the controlled quantity on the target quantity. Suitable for flow control, pressure control, temperature control and other process control. The control basic principle block diagram is as follows:

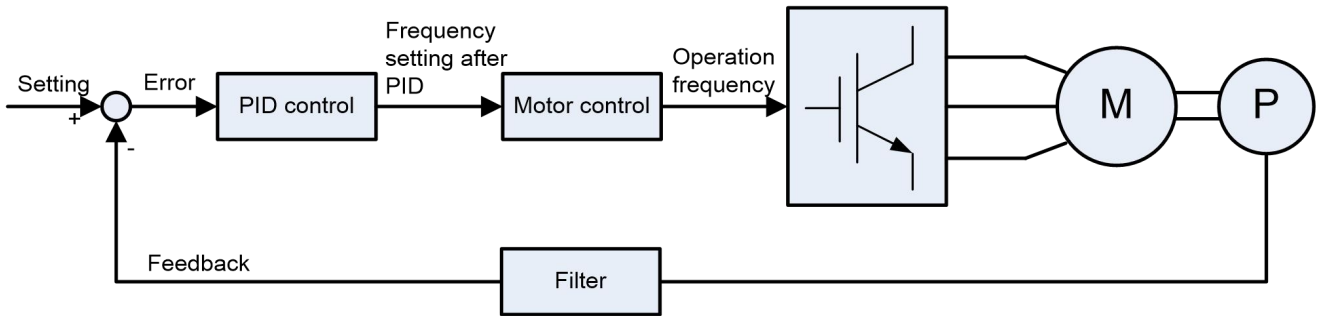

Figure 6.38 Block diagram of PID process control

f900~f916 define built-in process PID control function parameters of the VFD. The block diagram of process PID control function is shown as below:

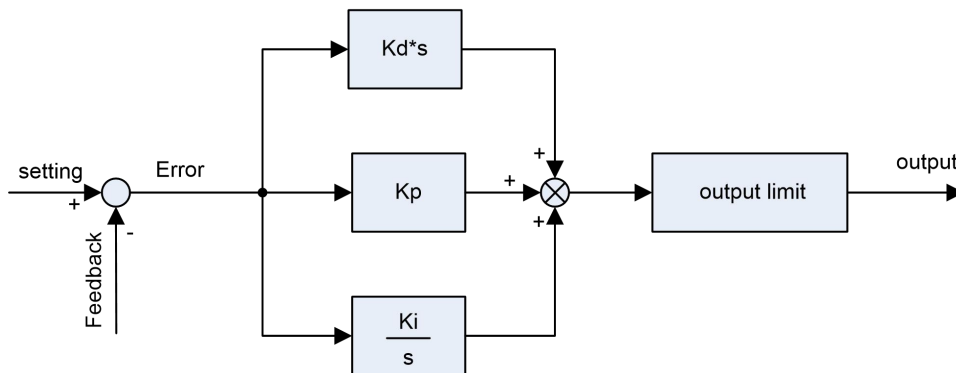

Figure 6.39 Block diagram of built-in PID controller

PID dormancy mode (the priority is reduced in order) :

- Pressure dormancy (key parameter: f912)
- Sleep at lower frequency (key parameter: f009)
- PID wake-up mode (the priority is reduced in order) :
- Deviation wake-up (key parameter: f907)
- Feedback value wake-up (key parameter: f908)
- Pressure wake-up (key parameter: f911)
- Frequency wake-up (key parameters: f009, f906)

NO.	Parameter Name	Setting Range	Default
f900	PID control enabled/disabled	0~2	0

0: Disabled

1: Enabled (Feedback: AI1)

2: Enabled (Feedback: AI2)

Note 1: The control parameter for enabling or disabling THE PID function is f900, not f003 for the given PID source selection parameter.

Note 2: PID given source (f003) and feedback source (f900) cannot be set to the same channel.

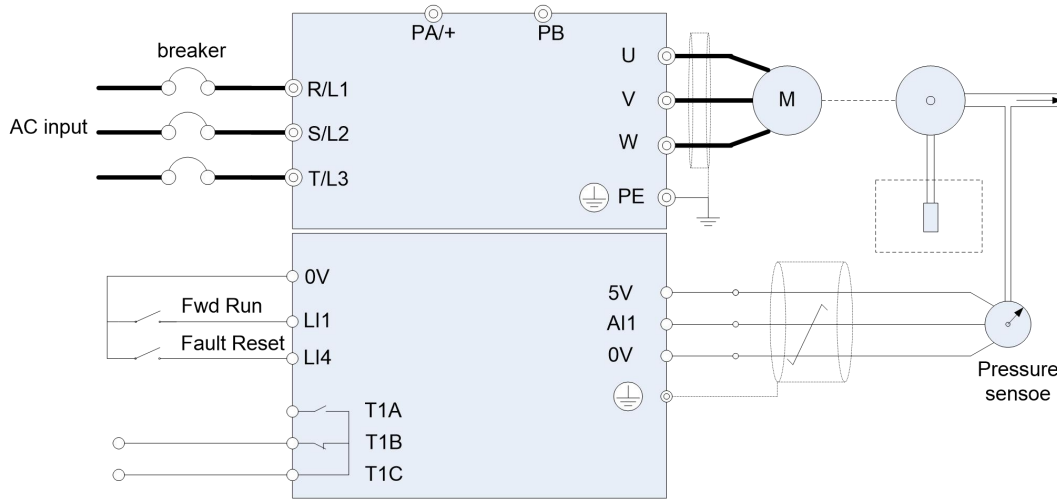

Figure 6.40 PID wiring example

Process quantity input data (frequency or percentage term) and feedback input data can be combined as follows for the PID control. See table 6.9.

Table 6.9 PID setting and PID feedback

PID given source		PID feedback source
f003 (f005) setting	Given source	f900 setting
0	built-in potentiometer	f900=1: AI1, 0~5VDC or 0~10V DC or 4~20mA DC.  f900=2: AI2, 0~10V DC.
1	AI1	
2	AI2	
3	Keyboard panel (given frequency) - not recommended	
4	Communication setting (given frequency)	
5	UP/DOWN from external contact	
6	-	
7	Keyboard panel (PID given) -f918	
- (when under remote control, f002=0)	Multistep speed setting	

Note 1: f003 is the multiplexing parameter for the given source of frequency and PID

When f900 =0 (PID is disabled), f003 is the given source of frequency;

When f900 ≠0 (PID enabled), f003 is the given source for THE PID.

Note 2: The control parameter for enabling or disabling PID functionality is f900, not f003.

Note 3: When the given PID source is f003=7, you can set THE PID by default by ▼ or by parameter f918. The two methods have the same effect.

Note 4: With the relevant parameters such as f021, the given parameters of f003 (main set) and f005 (secondary set) can be calculated as the final PID to achieve the primary and secondary operation function given by PID. For details, please see parameters f021 ~ f024 and f006.

NO.	Parameter Name	Setting Range	Default
f901	Proportional gain	0.01~100.0	varies by model
f902	Integral gain	0.01~100.0	varies by model
f903	Differential gain	0.00~2.55	0.00

The control effect of f901: The greater the setpoint is, the smaller the deviation between target value and feedback value after stability is. However, excessively large setpoint may arouse vibration in the controlled object and make it unstable. Furthermore, if the setpoint is small, the deviation between target value and feedback value after stability becomes greater.

The control effect of f902: Any residual deviation after proportional gain tuning can be cleared with time through integral gain function. Higher integral gain can realize rapid response to process deviation, but may result in instability such as oscillation.

The control effect of f903: Differential gain will tune the response time of the VFD according to the rapid change during the process. Unnecessary raise of of differential gain value may result in greater fluctuation of the motor speed and make the system unstable.

NO.	Parameter Name	Setting Range	Default
f904	PID controls wait/delay time	0~2400s	0

When f904 ≠0, the frequency converter will not enter the PID control immediately when starting, and the PID will only be enabled after the time delay set by f904.

During the time set by f904, PID is disabled, f003 is switched to select channel for the given source of frequency, and the motor is accelerated to the speed corresponding to the given source. For example, when f003 =7, the corresponding output frequency =f007\*f918/ f917.

NO.	Parameter Name	Setting Range	Default
f905	PI regulator deviates the input signal to take the reverse/direction	0~1	0

0: Disable/positive. PID feedback < timing, frequency converter output increases; On the contrary, the output frequency of the converter decreases.

1: Enable/react. PID feedback < timing, frequency converter output decreased; On the contrary, the output frequency of the converter increases.

Note: PID regulator negation is performed in two ways: Make f905=1, or define logic input function as 38 and the corresponding terminal is closed.

Note: PID regulator can be inverted in two ways. Let f905 =1, or define the logical input function as 38 and close the corresponding input terminal.

NO.	Parameter Name	Setting Range	Default
f906	Sleep mode awakening hysteresis bandwidth	0.0 Hz ~ f007	0.2



NO.	Parameter Name	Setting Range	Default
f907	Sleeping mode awakening threshold based on PI deviation	0.0 Hz ~f007	0.0
f908	Sleeping mode awakening threshold based on PI feedback	0.0 Hz ~f007	0.0
f910	wake up delay	0~600.0s	0.0
f911	Auto wake up level	0~100.0%	0.0

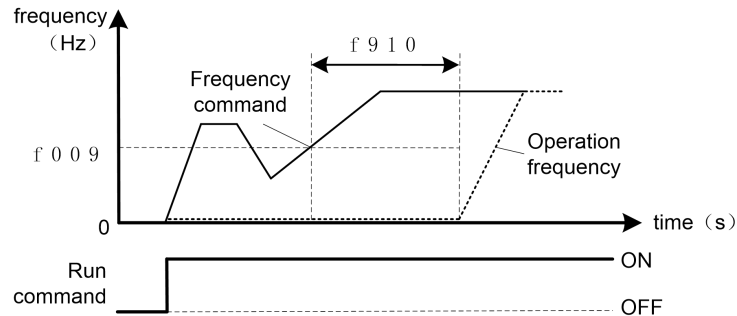

Figure 6.41 description of wake up from sleep mode

There are three types of wakeup: deviation wakeup, threshold wakeup (absolute value or percentage) and frequency wakeup. f905 =0 (deviation signal is taken to reverse/disable/positive effect) is described below.

(1) Deviation wake-up: If the following conditions are met, the frequency converter will quit the sleep state.

- (given - feedback) > wake-up bias (parameter f907);
- The state duration  $\geq$  wake control/delay time (f910).

(2) Threshold awakening: If the following conditions are met, the converter will quit the sleep state.

- feedback > wake-up threshold (parameter f908 or (f918\*f911%));
- The state duration  $\geq$  wake control/delay time (f910).

(3) Frequency awakening: If the following conditions are met, the frequency converter will enter the sleep state.

- Operating frequency  $\geq$  sleep frequency (f919) + wake frequency hysteresis bandwidth (f906);
- The duration of the two states above  $\geq$  wake control/delay time (f910).

Note 1: priority is: bias to wake up > threshold (absolute value) to wake up > threshold (percentage) to wake up > frequency, that is, only when high-priority parameter =0, will the low-priority wake-up mode be entered.

Note 2: The absolute value of f907 and f908 is adopted. When it is pressure signal, 1.00 means 1.0mpa.

Note 3: The percentage of f911 is adopted, and the reference value of 100% is PID given to f918.

Note 4: f906 cannot be 0 when sleeping through the lower frequency, otherwise there may be misoperation.

NO.	Parameter Name	Setting Range	Default
f909	sleeping mode action	0~1	0

0: Motor slowdown to a stop.

1: Motor keep running at the speed setting by f009.

NO.	Parameter Name	Setting Range	Default
f912	Dormancy threshold (percentage)	0~100%	0.0

NO.	Parameter Name	Setting Range	Default
f915	Sleep control/delay time	0~600.0s	0.1
f919	Dormancy frequency	0.0 Hz ~ f008	0.0
f920	Dormancy tolerance	0.0~25.0%	0.0

There are two ways of dormancy: feedback threshold dormancy (percentage) and frequency dormancy. f905 =0 (deviation signal is taken to reverse disable/positive effect) is described below.

(1) Feedback threshold sleep:

When the > dormancy threshold is fed back (f918\*f912%), and the duration  $\geq$  dormancy time (f915), it will enter the dormancy state.

(2) Frequency dormancy: when the following three conditions are met at the same time, the frequency converter will enter the sleep state.

- Feedback  $\geq$  (f918-f918 \* f920%);
- Output frequency  $\leq$  sleep frequency f919;
- The simultaneous duration of the above two is  $\geq$  sleep time f915.

Note 1: priority: threshold hibernation > frequency dormancy (that is, only when the dormancy threshold f912=0, enter the frequency dormancy mode).

Note 2: When f915 =0, the sleep function is disabled.

Note 3: Both f912 and f920 are set in percentages, and the reference value corresponding to 100% is GIVEN by PID f918.

NO.	Parameter Name	Setting Range	Default
f913	Upper limit of PID	0~100%	100.0
f914	Lower limit of PID	0~f913	0.0

When f900  $\neq$  0, f913 and f914 are valid, and the given PID is limited to f913 ~ f914.

Example: With f918 set to timing, the value of f918 itself may be out of the range of [f914, f913], but the final actual given will be limited to [f914, f913].

The setting of f913 and f914 adopts percentage, and the reference value corresponding to 100% is sensor range f917.

NO.	Parameter Name	Setting Range	Default
f916	PID given control deviation	0.0~100.0%	0.0
f917	Sensor range	0.00 ~ 99.99	1.00
f918	PID given	0.00 ~ f917	0.00





Both f917 and f918 are set in absolute value. When is the pressure signal, 1.00 represents 1.0mpa.

f916 is the maximum allowable deviation of the feedback from the given. Within the range of deviation, the PID controller stops working, and the accuracy and stability of the PID system can be adjusted by setting the value reasonably.

The setting of f916 USES a percentage, and the reference value of 100% is PID given to f918. Therefore, the allowable deviation range of actual pressure is: [f918 -- f918 \* f916%, f918 + f918 \* f916%].

## 6.11. Monitoring function parameter group

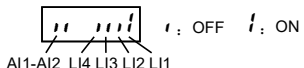
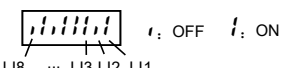
Table 6.10 Status monitor mode

NO.	Parameter Name	Description
u000	CPU1 Version	E.g:  , G-type, v= g; P-type, v= p;
u001	Operation frequency	Value is displayed in Hz/free unit. See f604.
u002	Direction of rotation	 Forward run,  Reverse run.
u003	frequency command value	Value is displayed in Hz/free unit. See f604.
u004	load current	The VFD output current (%/A) is displayed.
u005	input voltage (AC RMS)	The VFD input voltage (%/V) is displayed.
u006	output voltage (AC RMS)	The VFD output voltage command (%/V) is displayed.
u007	Input terminal status indicated	11kW or below:  ; OFF ; ON 15kW or above:  ; OFF ; ON
u008	Output terminal status indicated	 ; OFF ; ON , without T2 at 11kW or below
u009	cumulative operation time	(0.01=1 hour, 1.00=100 hours)
u010	Output speed	Displays the motor speed ( min-1) by calculating with output frequency and pole numbers.
u011	Rated current	The rated current of the VFD (A) is displayed.
u012	Torque current	The torque current (%/A) is displayed.
u013	Load current	The VFD output current (load current) (%/A) is displayed.
u014	Torque	The torque (%) is displayed.
u015	Input power	The VFD input power (kW) is displayed.
u016	Output power	The VFD output power (kW) is displayed.
u017	PID feedback	The PID feedback value is displayed. (Hz/free unit)
u018	Frequency command value (PID-computed)	The PID-computed frequency command value is displayed. (Hz/free unit)
u019	Integral input power	The integrated amount of power (kWh) supplied to the VFD is displayed.
u020	Integral output power	The integrated amount of power (kWh) supplied from the VFD is displayed.
u021	Communication counter	Displays the counter numbers of communication through the network.
u022	Normal state communication counter	Displays the counter numbers of communication only at normal state in the all communication through network.

NO.	Parameter Name	Description
u023	Cpu2 version	
u024	Parts replacement alarm information	ON: Needs to be replaced
u025	Cpu1 revision	
u026	PID setting	Displayed in % term.
u027	PID feedback	Displayed in % term.
u1--	Past trip 1	Enter into the display of detailed information on past trip 1
u2--	Past trip 2	Enter into the display of detailed information on past trip 2
u3--	Past trip 3	Enter into the display of detailed information on past trip 3
u4--	Past trip 4	Enter into the display of detailed information on past trip 4

Note 1: Items displayed can be changed by pressing ▲ or ▼ key in the monitor mode.

Note 2: You can switch between % and A (ampere)/V (volt), using the parameter f604 (current/voltage unit selection).

Note 3: The input/output voltage displayed is as large as the AC root-mean-square input.

Note 4: The integrated amounts of input and output power will be reset to zero, if you press and hold down the ENT key for 3 seconds or more when power is off or when the input terminal function 32 is turned on or displayed.

Note 5: The cumulative operation time increments only when the machine is in operation.

Note 6: At the occurrence of a trip, maximum values are not always recorded and displayed for reasons of detecting time.

Table 6.11 Display of detailed information on past trip n (n=1,2,3,4)

NO.	Parameter Name	Description
-	Cause of trip	E.g. e-01
un00	Continuous trips	The number of time the same trip occurred in succession is displayed. (Unit: times)
un01	CPU1 Version	E.g:  , G-type, v= g; P-type, v= p;
un02	Operation frequency	Value is displayed in Hz/free unit. See f604.
un03	Direction of rotation	Forward run,  Reverse run.
un04	frequency command value	Value is displayed in Hz/free unit. See f604.
un05	load current	The VFD output current (%/A) is displayed.
un06	input voltage (AC RMS)	The VFD input voltage (%/V) is displayed.
un07	output voltage (AC RMS)	The VFD output voltage command (%/V) is displayed.
un08	Input terminal status indicated	11kW or below:  .

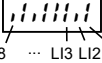
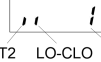
NO.	Parameter Name	Description
		15kW or above:  : OFF : ON L18 ... L13 L12 L11
un09	Output terminal status indicated	 : OFF : ON , without T2 at 11kW or below T2 LO-CLO T1

Note 1: If no trip occurred in the past, the message “nerr” will be displayed. Detailed information for past trip is not accessed.

Note 2: Details on a past trip can be displayed, even after the VFD is turned off or reset.

## 7. FAULT DIAGNOSIS AND MEASURES

### 7.1. Fault code, cause and measures

When fault (failure) occurs, the VFD takes the following actions: The keyboard panel blinks to display the fault code, the VFD stops output and the motor freely stops.

Table 7.1 Fault display and measures

Code of fault	Type of fault	Possible cause	Measures (troubleshooting)
e-01	Overcurrent protection	<ul style="list-style-type: none"> <li>Acceleration time is too short.</li> <li>V/f parameter is wrongly set.</li> <li>When the VFD starts, the load is still in rotation.</li> <li>VFD is supplying power to low-impedance motor.</li> <li>Interphase short circuit or earthing failure.</li> <li>Abrupt fluctuation of the load</li> </ul>	<ul style="list-style-type: none"> <li>Increase acceleration parameter (F010 or f618) and the deceleration time (F011 or f519)</li> <li>Select the correct setpoint for V/f.</li> <li>Adopt forward/reverse speed tracking and restart function (STR function).</li> <li>Tune the switching frequency.</li> <li>Check wiring to see if there is Interphase short circuit or earthing failure.</li> <li>Reduce fluctuation of the load</li> </ul>
e-02	Interphase short circuit	<ul style="list-style-type: none"> <li>Interphase output is short circuit.</li> <li>Motor impedance is too low.</li> </ul>	<ul style="list-style-type: none"> <li>Confirm the wiring and insulation status.</li> </ul>
e-03	Starting overcurrent	<ul style="list-style-type: none"> <li>earthing failure</li> <li>IGBT unit damage</li> </ul>	<ul style="list-style-type: none"> <li>Confirm whether the wiring and device are earthing</li> <li>Connect with factory</li> </ul>
e-04	Earthing fault	<ul style="list-style-type: none"> <li>earthing failure</li> <li>IGBT unit damage</li> </ul>	<ul style="list-style-type: none"> <li>Confirm whether the wiring and device are earthing</li> <li>Connect with factory</li> </ul>
e-06	Underload fault	<ul style="list-style-type: none"> <li>VFD 's output current is lower than low current detection threshold.</li> </ul>	<ul style="list-style-type: none"> <li>Check whether f407~f410 are correctly set.</li> </ul>
e-07	Overtorque fault	<ul style="list-style-type: none"> <li>The motor estimates that the torque has reached the level set by f412.</li> </ul>	<ul style="list-style-type: none"> <li>Adjust the settings of f411~f414.</li> <li>Confirm the load status.</li> </ul>
e-11	Undervoltage fault	<ul style="list-style-type: none"> <li>Abnormal fluctuation of input voltage; Power network capacity higher than 200 kVA; There is switchable capacitor to improve power factor on the power network; Machine that SCRs is connected to the power network.</li> <li>VFD starts the load already in rotation.</li> <li>There is possible phase failure.</li> <li>The deceleration time is too short.</li> </ul>	<ul style="list-style-type: none"> <li>Install input reactor or use braking resistance.</li> <li>Adopt forward/reverse speed tracking and restart function (STR function) (f500 = 1)</li> <li>Set f418 = 2.</li> <li>Determine the cause of output phase failure (such as poor connection, open circuit of output or open circuit of motor winding) and correct it.</li> <li>Increase the deceleration time (F011 or f519)</li> <li>Enable overvoltage fault protection (f415).</li> </ul>

Code of fault	Type of fault	Possible cause	Measures (troubleshooting)
e-12	DC bus undervoltage fault	<ul style="list-style-type: none"> <li>Input voltage is too low.</li> </ul>	<ul style="list-style-type: none"> <li>Check input voltage.</li> <li>Set f417 to select alarm or tripping.</li> <li>Adopt forward/reverse speed tracking and restart function (STR function) (f500 = 1)</li> <li>Set f418= 2.</li> </ul>
e-21	VFD overload	<ul style="list-style-type: none"> <li>Acceleration time is too short.</li> <li>DC braking current level is too high.</li> <li>V/f parameter is wrongly set.</li> <li>When the VFD starts, the load is still in rotation.</li> <li>The load is too large.</li> </ul>	<ul style="list-style-type: none"> <li>Increase acceleration parameter F010 or f518). Decrease the setting of f507 or f508.</li> <li>Correctly set V/f parameter.</li> <li>Set parameter f418 = 2.</li> <li>Adopt one VFD with higher rated power.</li> </ul>
e-22	Motor overload	<ul style="list-style-type: none"> <li>V/f parameter is wrongly set.</li> <li>The motor is blocked.</li> <li>The motor continues to run at low speed.</li> <li>The load applied to the motor is too large.</li> </ul>	<ul style="list-style-type: none"> <li>Correctly set V/f parameter.</li> <li>Check the load.</li> </ul>
e-23	Braking resistor overload	Improper specification selection for braking resistor	Select competent braking resistor. Prohibit braking resistor overload protection f527=2
e-24	VFD overheat fault	<ul style="list-style-type: none"> <li>VFD 's cooling fan does not work.</li> <li>Environment temperature is too high.</li> <li>Certain ventilation opening is blocked.</li> <li>There is heat source near the VFD .</li> <li></li> </ul>	<ul style="list-style-type: none"> <li>Reset the VFD 's fault after cooling and restart the VFD .</li> <li>Expand the free space around the VFD ; Remove all heat sources near the VFD to lower the environment temperature.</li> </ul>
e-25	Motor PTC overheating fault	<ul style="list-style-type: none"> <li>External PTC embedded in the motor winding indicates existence of motor overheating.</li> </ul>	<ul style="list-style-type: none"> <li>Correct motor overheating.</li> <li>Check whether PTC is working properly.</li> <li>Check logic input functions 27 and 28.</li> </ul>
e-31	EEPROM fault	<ul style="list-style-type: none"> <li>Data writing and read errors occur.</li> <li>The VFD has power failure during parameter reset.</li> </ul>	<ul style="list-style-type: none"> <li>Power on the VFD to eliminate the fault. If the fault can not be eliminated, contact our company or its distributor for maintenance or repair of the VFD .</li> </ul>
e-32	Control board fault	<ul style="list-style-type: none"> <li>Control board cannot work</li> </ul>	<ul style="list-style-type: none"> <li>Connect manufacturer to maintain</li> </ul>
e-33	Communication fault	<ul style="list-style-type: none"> <li>Network communication error.</li> </ul>	<ul style="list-style-type: none"> <li>Check network control devices and cables.</li> <li>Check the setting of communication overtime parameter f803.</li> <li>Check remote keyboard panel</li> </ul>

Code of fault	Type of fault	Possible cause	Measures (troubleshooting)
			cable.
e-34	Current sensor fault	<ul style="list-style-type: none"> <li>The current sensor is in abnormal status.</li> </ul>	<ul style="list-style-type: none"> <li>Replace the VFD .</li> </ul>
e-35	Network fault	<ul style="list-style-type: none"> <li>Network error</li> </ul>	<ul style="list-style-type: none"> <li>Check network control devices and cables.</li> </ul>
e-36	VFD type error	<ul style="list-style-type: none"> <li>VFD hardware fault</li> </ul>	<ul style="list-style-type: none"> <li>f120=7</li> <li>If error is still, connect manufacturer to maintain</li> </ul>
e-38	AI1 signal Loss	<ul style="list-style-type: none"> <li>AI1 analog signal level is lower than the level set by the parameter f422.</li> </ul>	<ul style="list-style-type: none"> <li>Check signal on AI1 to eliminate the cause of signal loss.</li> <li>Confirm whether f422 is correctly set.</li> </ul>
e-39	VFD inside communication error	<ul style="list-style-type: none"> <li>communication error between keyboard and control board CPU</li> </ul>	<ul style="list-style-type: none"> <li>Connect manufacturer to maintain</li> </ul>
e-41	Input phase failure	<ul style="list-style-type: none"> <li>The input side of the main circuit is phase failure.</li> <li>The inside component of the VFD is in abnormal state.</li> </ul>	<ul style="list-style-type: none"> <li>Determine the cause of input phase failure and correct it.</li> <li>Set f405 = 0.</li> </ul>
e-42	Output phase failure	<ul style="list-style-type: none"> <li>The output side of the main circuit is phase failure.</li> </ul>	<ul style="list-style-type: none"> <li>Determine the cause of input phase failure (such as poor connection, open circuit of output or open circuit of motor winding) and correct it.</li> <li>Set f406 = 0.</li> </ul>
e-43	Emergency stop fault	<ul style="list-style-type: none"> <li>Use the keyboard panel to perform stop operation when the motor works under remote mode.</li> </ul>	<ul style="list-style-type: none"> <li>Perform fault reset.</li> </ul>
e-45	Torque boost is too large	<ul style="list-style-type: none"> <li>Setting of torque boost parameter f203 is too high.</li> <li>Motor impedance is too low.</li> </ul>	<ul style="list-style-type: none"> <li>Repeat self-tuning of the VFD and downward tune parameter f203.</li> </ul>
e-46	Self-setting error	<ul style="list-style-type: none"> <li>Confirm whether motor rated parameter settings are correct.</li> <li>The motor capacity is far smaller than that of the VFD .</li> <li>Cable of the motor is too thin.</li> <li>Motor is still in rotation when the self-setting starts.</li> </ul>	<ul style="list-style-type: none"> <li>Correctly set motor rated parameters.</li> <li>Use VFD with larger capacity.</li> <li>Apply thicker cable of the motor.</li> <li>Confirm the motor has stopped before the self-setting begins.</li> </ul>
e-98	Pull-out keypad communication fault	<ul style="list-style-type: none"> <li>Communication fault between pull-out keypad and internal CPU</li> </ul>	<ul style="list-style-type: none"> <li>Please contact us</li> </ul>
e-99	Big power display communication fault	<ul style="list-style-type: none"> <li>Communication fault for VFD above 15kw(including) display keypad and internal CPU</li> </ul>	<ul style="list-style-type: none"> <li>Please contact us</li> </ul>



## 7.2. Description of alarm and indication code

Table 7.2 Alarm display and measures

Code	Description	Cause	Measures
a-00	Fault reset is acceptable.	Under fault code display state, press STOP key and a-00 is displayed.	Press the STOP key again and the fault is eliminated.
a-01	Undervoltage indication	Insufficient input voltage	Check the 3-phase input power supply. If the power supply is normal, the VFD has to be repaired.
0.0 (flash)	“Running ready” is invalid	Under remote control mode the corresponding terminal to the logic input function 1 is not closed.	Configure one logic input function as 1, and close this terminal.
a-05	Abnormal setting of frequency point	Frequency points at point 1 and point 2 are set too closely.	Do not set f325 and f327 too closely. Do not set f329 and f331 too closely.
a-06	Free stop action during transient power failure.	f418 is set to 2 and transient power failure occurs.	Input running signal to the VFD again or reset the VFD .
a-07	In DC braking	DC braking function is activated.	If the code disappears in several seconds, the VFD comes back to normal.
a-08	In running retrial	The VFD is in the process of restart. Forward/reverse speed tracking and restart function (STR function) is activated.	The alarm code is momentarily displayed then disappears, and the VFD restarts.
a-10	In low speed sleep	See parameter f501.	Disabled This function or raise the frequency instruction to f006+f906.
a-11	Key fault on the keyboard	Certain key on the keyboard panel is continously pressed more than 20 s or the panel is damaged.	If all keys are released but the alarm does not disappear, the VFD has to be repaired.
a-12	In the process of parameter initialization	See parameter F120.	If the alarm code is momentarily displayed and then disappears, the VFD comes back to normal.
a-13	Loss of analog signal	Analog input terminal detection level is lower than the setting level of f422.	Check analog input terminal
e1	Exceeding displayed digit number by 1 digit	Displayed digit number exceeds 4 digits.	Try to reduce the setpoint of f422.
eun1	In the process of self-setting	VFD is performing self-setting.	If the alarm code is momentarily displayed and then disappears, the VFD comes back to normal.

Table 7.3 Display of early warning code

Code	Type	Description
---c	Overcurrent early warning	VFD is in current amplitude limiting state. See parameters f107 and f111.
--u-	Overvoltage early warning	VFD approaches overvoltage fault. See parameters f415 and f416.
- --	Overload early warning	This code is displayed when the motor or VFD overload counter exceeds 50%.
h---	Overheat early warning	VFD approaches overheat fault.

Note: Early warning types can occur simultaneously. E.g, when overheat early warning and overcurrent early warning happen in the same time, the corresponding code is h--c.

### 7.3. Restart of the VFD after fault occurs

After failure occurs in the VFD , it can be restarted only when the cause of the failure has been eliminated. Please follow the undermentioned operations to realize fault reset of the VFD .

1 When the command source of the VFD is keyboard panel (under local control mode, or under remote mode and f002 = 1), press STOP key on the keyboard panel after the fault is eliminated. The keyboard will display a-00. Press the STOP key again, and the VFD realizes fault reset. At this moment it is allowable toto re-supply power to the motor.

2 When the VFD is under remote control mode and f002 = 0, set the input function configuration of any logic input terminal to 10. Then the VFD can use this terminal to perform fault reset.

3 When the VFD is under remote control mode and f002 = 2, fault reset is realized through remote communication devices. See *Appendix A: Serial communication*.

4 Switch off the VFD and power it on again.

Note: When the fault is motor or frequency overload (e-21 or e-22), VFD reset function can not be performed if computed cooling time is not up. The computed cooling time is specified as: e-21, 30 seconds after the fault occurs; e-22, 120 seconds after the the fault occurs.

## 8. APPENDIX A: SERIAL COMMUNICATION

Serial communication is the information exchange channel of the VFD with upper computer. Through serial communication, users can use personal computer or industrial control equipment (such as PLC etc) as host to set VFD (slave)'s running frequency or command, modify or read data, read working state and fault information etc and realize remote or centralized control of the VFD .

Variable Frequency Drive adopt RS-485 bus and Modbus protocol for serial communication.

### A1. RS-485 bus

The hardware circuit of serial communication for Variable Frequency Drive follows RS-485 standard and a RJ45 interface is provided. Here RS-485 two-wire wiring method is adopted. The array sequence of the corresponding pins of RJ45 interface is shown as below:

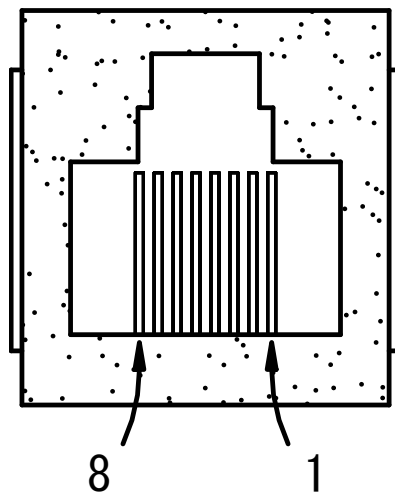

Figure A.1 RJ45 front view

Table A.1 Pin output signal allocation

Pin	Signal description
1	Reserved
2	Common port (signal ground & power ground)
3	Reserved
4	A (RS-485)
5	B (RS-485)
6	Reserved
7	+24 V
8	Common port (signal ground & power ground)

RS-485 two-wire wiring method is half-duplex serial communication. At the same moment the host and slave can not simultaneously transmit or receive data. Only one transmits data and another receives them.

RS-485 two-wire wiring method supports bus-type topological structure. At most 32 nodes can be connected to the same bus. Normally master-slave communication method is adopted in the RS-485 communication network, namely, one master commands as many as 31 slaves.

Under the circumstance of multi-computer communication or long-distance communication, it is suggested to connect the signal ground of the master station with the common port of the VFD to raise the ant-interference ability of communication.

## A2. Modbus protocol

Modbus is a master-slave communication protocol. The master governs the whole communication process. Only when the master sends command to the slave, the slave executes the actions or/and send feedback information to the master. Otherwise the slave performs no operation and the slave can not communicate with each other directly.

There are two kinds of dialogues between the master and slaves:

(1) Point-to-point: Master sends command individually to a certain slave which executes action or/and sends feedback information.

When the master command is correct, the slave executes corresponding actions and transmits feedback of result information to the master.

When the master command is false, the slave transmits feedback of error information to the master but executes no actions.

(2) Broadcast mode: The master sends command to all slaves which execute action but send no feedback information.

Modbus protocol has two kinds of transmission patterns: Modbus RTU and Modbus ASCII. Variable Frequency Drive supports Modbus RTU.

### A2.1 Description of Modbus-RTU message format

When the Modbus-RTU mode is used for communication, the communication information (message) is represented directly with hexadecimal code (1-9, A-F). Two hexadecimal codes form one byte. The message format is shown as below:

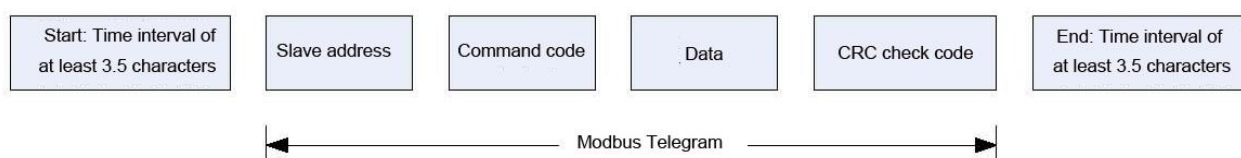

Figure A.2 Modbus Message Format

As shown in Figure A.2, during the communication process, the master and slave determine the start and end of Modbus message according to time interval of at least 3.5 characters. The message includes the complete data information to be transmitted: in the sequence of slave address, command code, data and CRC code. Its length varies with the change of the command code.

The message of Modbus-RTU is classified into three types and two formats:

- 1) Request (Interrogation) message: Command request message transmitted by master to slave;
  - 2) Normal response message: The slave's feedback message when the master's command is correct.
  - 3) Error response message: The slave's feedback message when the master's command is false / invalid.
- 1) and 2) have the same format, while 3) adopts other format.

1. Format of request message and normal response message.

Table A.2 Format of request message and normal response message

Number	Name	Function
1	Slave address	<ul style="list-style-type: none"> <li>Configured from 0 to 247</li> <li>All slaves execute command but provide no feedback information; If slave address is set to 1~247, the dialog is point-to-point mode. All address-matching slaves execute command and provide feedback information.</li> <li>Under the point-to-point mode, when the matching slave responses, it sends back the slave address of itself.</li> </ul>
2	Command code	<ul style="list-style-type: none"> <li>Variable Frequency Drive supports part of command codes of Modbus protocol.</li> <li>All slaves execute command code and the matching slave responses code include:                             <ol style="list-style-type: none"> <li>03H:Read one word (2 bytes)</li> <li>06H:Write one word (2 bytes)</li> </ol> </li> <li>During error response, the feedback command code of the slave = the request command code of the master + 80H.</li> </ul>
3	Data	<ul style="list-style-type: none"> <li>This part is the main content of communication and the core of data exchange. Its content and length vary with the variation of the command codes. See the following concrete descriptions of every command code.</li> </ul>
4	CRC code	<ul style="list-style-type: none"> <li>Cyclical redundancy check (CRC) code is used for error detection of received data done by the receiving equipment and for judging whether the received data are correct. Please refer to “A2.3 Cyclical redundancy check (CRC)” for generation of CRC code.</li> </ul> <p>Note: CRC code first sends low bytes then high bytes. Except this, all messages of Modbus-RTU adopt the transmission sequence of “high bytes first - then low bytes”.</p>

## A2.2 Detailed message description of different commands

### A2.2.1 Read N words (2\*N bytes) -- command code 03H

1. Master request message

Table A.3 Command code 03H host query message format

Slave address	Command code	Communication address		Read word number		CRC code	
		High byte	Low byte	High byte	Low byte	High byte	Low byte
1 byte	1 byte	2 bytes		2 bytes		2 bytes	
	03H			00H	01H		

- Slave address and CRC code: See “Table A.2”.
- Command code: 03H, request to read N words (2\*N bytes) of the slave machine. Notice that N is at most 5.
- Communication address: The address of read data. This is not the real physical address for data storage, but a number corresponding to the data. Every control, state or monitoring parameter of Variable Frequency Drive corresponds to a communication address. See “A2.5 Communication parameter”.

4) Read word number: The length of the read data with the word (2 bytes) as the count unit. When current request asks for reading one word, it is set to 0001H.

2. Message of slave normal response

Table A.4 Command code 03H of slave machine normal reply message

Slave address	Command code	Read bytes number	Read bytes number 2		...	Read bytes number N		CRC code	
1 byte	1 byte	1 byte	2 bytes		...	2 bytes		2 bytes	
			High byte	Low byte	...	High byte	Low byte	High byte	Low byte
	03H				...				

- 1) Slave address and CRC code: See "A2.2".
- 2) Command code: 03H. The same as the master request command code.
- 3) Read word number: The length of the read data with byte as the count unit. When current master requests to read one word, set read byte number transmitted from the slave to 02H.

Note: The count unit of the length of the read data is different from that of request message.

- 4) Read data: Data corresponding to the communication address in the request message.

Note: Read data firstly sends high byte then low byte in an opposite direction to CRC code.

3. Slave error response message

Table A.5 Slave error response message of Command code 03H

Slave address	Command code	Error code	CRC code	
1 byte	1 byte	1 byte	2 bytes	
			Low byte	High byte
	83H			

- 1) Slave address and CRC code: See "A2.2".
- 2) Command code: 83H. It is = 03H + 80H.
- 3) Error code. For detail see "A2.4 Error code".
- 4) Example: Read upper limit frequency.

Master request message: 01 03 00 08 00 01 05 C8

Normal response message: 01 03 02 13 88 B5 12 (Suppose that current upper limit frequency is 50 Hz)

Error response message: 01 83 03 01 31 (Suppose that read word number is altered from 0001 to 0002)

## A2.2.2 Write one word (2 bytes) — Command code 06H

### 1. Master request message

Table A.6 Format of master request message

Slave address	Command code	Communication address		Write data		CRC code	
1 byte	1 byte	2 bytes		2 bytes		2 bytes	
		High byte	Low byte	High byte	Low byte	Low byte	High byte
	06H						

1) Slave address and CRC code: See “Table A.2”.

2) Command code: 06H. Request to write 1 word (2 bytes) of the slave.

3) Communication address: The address of read data. This is not the real physical address for data storage, but a number corresponding to the data. Every control, state or monitoring parameter of Variable Frequency Drive corresponds to a communication address. See “A2.5 Communication parameter”.

4) Write data: Request data written by the slave.

### 2. Slave normal response message

Table A.7 Slave normal response message

Slave address	Command code	Communication address		Write data		CRC code	
1 byte	1 byte	2 bytes		2 bytes		2 bytes	
		High byte	Low byte	High byte	Low byte	Low byte	High byte
	06H						

Slave’s normal response message is the same as the master’s request message.

### 3. Slave error response message

Table A.8 Format of slave error response message

Slave address	Command code	Error code	CRC code	
1 byte	1 byte	1 byte	2 bytes	
			Low byte	High byte
	86H			

1) Slave address and CRC code: See “Table A2.2”.

2) Command code: 86H. It is = 06H + 80H.

3) Error code. For detail see “A2.4 Error code”.

### 4. Example: To write upper limit frequency

Master request message: 01 06 00 08 13 24 05 23 (Suppose that the set upper limit frequency is 49 Hz)

Normal response message: 01 06 00 08 13 24 05 23

Error response message: 01 86 04 43 A3 (Suppose current writing operation cannot be performed)

### A2.2.3 Write multiple words (2\*N bytes) -- command code 10H

#### 1.Host query message

Table A.9 Format of host query message in command code 10H

Slave address	Command code	Communication address		Write words		Write data	Write 1		...	Write N		CRC code	
1 byte	1 byte	2 bytes		2 bytes		1 byte	2 bytes		...	2 bytes		2 bytes	
		Low byte	High byte	Low byte	High byte		Low byte	High byte	...	Low byte	High byte	Low byte	High byte
	10H								...				

(1) Slave address and CRC check code: see Table A.2.

(2) Command code: 10H, N words (2\*N bytes) of the request write slave machine. Notice that N is at most 5.

(3) Communication first address: the first address to write data. The address is not the actual physical address of the data, but a number corresponding to the data. Each control, state and monitoring parameter of the converter corresponds to a communication address, see "A2.5 Communication Parameters" for details.

(4) Write words: the number of slave words written.

(5) Number of bytes written: Number of bytes written by slave = number of words written \*2.

(6) Write data 1~ write data N: The data requested to be written from the machine.

#### 2.The slave answers the message normally

Table A.10 Command code 10H for slave normal reply message format

Slave address	Command code	Communication address		Write data		CRC code	
1 byte	1 byte	2 bytes		2 bytes		2 bytes	
		Low byte	High byte	Low byte	High byte	Low byte	High byte
	10H						

(1) Slave address and CRC check code: see Table A.2.

(2) Command code: 10H, which is consistent with the request command code of the host.

(3) Communication first address: The same as the communication first address of the host.

(4) Write words: the same as the number of words written by the host.

#### 3.Slave machine error response message

Table A.11 Format of slave error response message in command code 10H

Slave address	Command code	Error code	CRC code	
1 byte	1 byte	1 byte	2 bytes	
			Low byte	High byte
	90H			

(1) Slave address and CRC check code: see Table A.2.

(2) Command code: 90H, namely the sum of 10H and 80H.

(3) Error code: see "A2.4 Error code" for details.



4.Example: Write five consecutive parameters starting with the f300 parameter

Host query message: 01 10 03 00 05 0A 00 01 00 03 00 04 00 01 00 00 0B 9D AE

(Suppose f300=1;f301 = 3;f302 = 4;f303 = 1;f304 =11 five parameters)

Normal reply message: 01 10 03 00 00 05 00 4E

Error response message: 01 90 03 0C 01 (assuming incorrect data setting)

## A2.3 Cyclic redundancy check (CRC)

Modbus-RTU's communication message uses cyclic redundancy check (CRC) for transmission error check.

During each communication, the sender computes CRC code of transmitted data according to CRC rules, then sends the data by attaching the CRC code to them; After receiving the data, the receiver re-computes the CRC code according to the same rules. The computed content does not include the received CRC code. The receiver compares the re-calculated CRC code with the received code. If they are not the same, the transmitted data are determined to be false.

Variable Frequency Drive adopts CRC16 rule for message check of serial communication. Every CRC code consists of 2 bytes, including 16-bit binary value. The calculation is as follows:

- 1) Initialize CRC register (16 bit) to 0xFFFF;
  - 2) Perform XOR to the first byte (slave address) and the low 8 bits of the register, and then put the computed result back to CRC register;
  - 3) Make a right shift by 1 bit to the content of CRC register and fill in the highest bit with 0;
  - 4) Check the shift-out bit after right shift;
    - If the shift-out bit is 0, repeat 3), namely, make another right shift;
    - If the shift-out bit is 1, make XOR to CRC register and 0xA001, and put the computed result back to the CRC register;
  - 5) Repeat steps 3) and 4) until 8 right shifts are made. Implement the same procedure to all the 8-bit data;
- Repeat steps 2) ~ 5) to implement the processing of the next byte in the message;
- 7) After all the bytes in the message are computed according to the above procedures, the content in the CRC register is the CRC code.

After the CRC code is acquired through the above-mentioned method, attach it to the transmitted data and send them. It is necessary to exchange the high and low bytes of the CRC code, namely, to send the low byte firstly and then the high byte.

There are two methods to compute CRC code with software: table look-up and on-line computation. Computation speed of the table look-up is fast but its table data occupy considerable space; On-line computation method requires no table data. It saves space but needs much time. Suitable computation method is selected according to concrete circumstance during application.

## A2.4 Error code

When the slave is not able to implement master's request, the slave gives feedback of corresponding error code to indicate cause of the current error. Refer to the following table for the concrete meaning of error code.

Table A.12 Description of error code

Error code	Description
01	Command code error
	<ul style="list-style-type: none"> <li>Command code other than 03H 06 and 10H is set in the request message</li> </ul>
02	Communication address error
	<ul style="list-style-type: none"> <li>Visited communication address does not exist.</li> <li>The register corresponding to the communication address does not permit performance of the action demanded by the current command code.</li> </ul>
03	Data setting error
	<ul style="list-style-type: none"> <li>Written data exceeds the allowable range of the register.</li> <li>Improper setting of certain parameter in the request message.</li> </ul>
04	Unable to continue implementing the master's request.
	<ul style="list-style-type: none"> <li>Error occurs during the process of writing data.</li> <li>Currently the register corresponding to the communication address does not permit performance of the action demanded by the command code.</li> </ul>

## A2.5 Communication parameter

### 1. Control parameter

Control parameters are edited through serial communication in order to realize VFD 's function setting, running frequency setting, start/stop control and logic/analog output setting.

#### 1) Basic parameters

Basic parameters consist of 10 groups: f0 – f9. They are used to control the function setting of the VFD . Their detailed description, communication addresses and value ranges are shown in “5. Detailed description of parameters”.

Note: The communication address of the basic parameter corresponds to its display code. However, it is required to change F at the highest bit to 0;

Example: The display code of parameter “Running command selection” is f001, so the corresponding communication address is 0001;

Another example: The display code of parameter “Default keyboard panel display value” is f702, so the corresponding communication address is 0702.

#### 2) Communication control word (Communication address: fa05)

#### 3) Communication running frequency setting (Communication address: fa08)

Table A.13 Detailed description of communication control word

Bit	Description of function	0	1	Default value
0	JOG	NO-JOG	Jog frequency	0
1	Forward/reverse rotation	Forward rotation	Reverse rotation	0
2	Running/stop	Stop	Running	0

Bit	Description of function	0	1	Default value
3	Free stop	No action	Free stop	0
4	Emergency stop	No action	Emergency stop	0
5	Fault reset	No action	Reset	0
6	Given frequency by communication	Disable	Enable	0
7	Given code by communication	Disable	Enable	0
8	Multi-speed 1	OFF	ON	0
9	Multi-speed 2	OFF	ON	0
10	Multi-speed 3	OFF	ON	0
11	Multi-speed 4	OFF	ON	0
12	Motor parameter switch	1nd Motor Parameter	2nd Motor Parameter	0
13	PID control Disabling	Enabling PID control	Disabling PID control	0
14	Acceleration/ deceleration curve switch	Acceleration/ deceleration curve 1	Acceleration/ deceleration curve 2	0
15	DC braking	No DC braking	DC braking start	0

Table A.14 Communication running frequency setting

Bit	Description of function	Default
0-15	Running frequency data of communication setting. Hexadecimal setting: 50Hz→(50Hz)x100 = 5000→1388Hz It is if setting: 50Hz, write 1388H in the FA08 address	0.0

#### 4) Communication analog output setting (Communication address: FA16)

Table A.15 Communication analog output setting

Bit	Description of function	Lower limit	Upper limit	Default
0-15	Analog output data of communication setting (in correspondence with analog output function 10)	0 (0000H)	1023 (03FFH)	0

#### 2. Monitoring parameter

Monitoring parameters can be read through serial communication to see the running state of the converter. The following table is the description of monitoring parameters.

Table A.16 Monitoring parameters 1

No.	Communication address	Description of function	Unit	Note
1	FD03	Real-time running state	-	See table A.18 for details
2	FD12	Real-time running frequency	0.01 Hz	
3	FE18	Actual output frequency	0.01 Hz	

No.	Communication address	Description of function	Unit	Note
4	FE09	DC bus input voltage	0.01 %	
5	FE10	Output voltage	0.01 %	
6	FE08	Output current	0.01 %	
7	FE20	Output torque	0.01 %	
8	FE29	Output power	0.01 kW	
9	FE50	Motor speed (estimated)	1 rpm	
10	FE11	Logic input	-	See Table A.19 for details
11	FE12	Logic output	-	See Table A.20 for details
12	FE30	Logic input AI1 (10-bit accuracy)	-	Range (0-1023)
13	FE31	Logic input AI2 (10-bit accuracy)	-	Range (0-1023)
14	FC39	Fault monitoring	-	See A.21 for details
15	FE41	Frequency converter rated current		

Table A.17 Monitoring parameter specification 2

No.	Communication address	Description of function	Unit	Note
1	E000	Real-time running state	-	See table A.18 for details
2	E001	Real-time running frequency	0.01Hz	
3	E002	output current	0.01A	
4	E003	Fault monitoring	-	See Table A.21 for details
5	E004	PID given		
6	E005	PID feedback		
7	E006	output voltage	V	
8	E007	Motor speed (estimated)	1rpm	
9	E008	Output torque	0.01%	
10	E009	DC bus input voltage	V	
11	E010	Input power	0.01kW	
12	E011	Output power	0.01kW	
13	E012	Input power accumulates	W.h	
14	E013	Output power accumulation	W.h	
15	E014	Cumulative running time	h(hour)	

No.	Communication address	Description of function	Unit	Note
16	E015	Logic input	-	See Table A.19 for details
17	E016	Logic output	-	See Table A.20 for details
18	E017	Analog input AI1 (10-bit precision)	-	Range (0-1023)
19	E018	Analog input AI2 (10-bit precision)	-	Range (0-1023)

Table A.18 Real-time running state monitoring

Communication address	Description of function		
FD03	Real-time running state monitoring		
Bit	Description	0	1
0	Reserved	-	-
1	Fault	No fault	Tripping
2-8	Reserved	-	-
9	Forward/reverse rotation	Forward rotation	Reverse rotation
10	Running/stop	Stop	Running
11-15	Reserved	-	-

Table A.19 Logic input state monitoring

Communication address	Description of function		
FE11	Logic input state monitoring		
Bit	Description	0	1
0	Terminal L1	OFF	ON
1	Terminal L2	OFF	ON
2	Terminal L3	OFF	ON
3	Terminal L4	OFF	ON
4	Terminal L5	OFF	ON
5	Terminal L6	OFF	ON
6	Terminal L7 or As AI1 during logic input	OFF	ON
7	Terminal L8 or As AI1 during logic input	OFF	ON
8-15	Reserved	-	-

Table A.20 Logic Output state monitoring

Communication address	Description of function
FE12	Logic output state monitoring

Bit	Description	0	1
0	Terminal LO1-CLO1	OFF	ON
1	Relay T2	OFF	ON
2	Relay T1	OFF	ON
3-15	Reserve	-	-

Table A.21 Fault monitoring

Communication address	Description of function	
FC39	Fault monitoring	
Value	Corresponding fault	Panel display
0000H	No fault	nerr
0001H	Acceleration overcurrent	e-01
0002H	Deceleration overcurrent	e-01
0003H	Constant speed overcurrent	e-01
0008H	Input phase failure	e-41
0009H	Output phase failure	e-42
000AH	Acceleration overvoltage	e-11
000BH	Deceleration overvoltage	e-11
000CH	Constant speed overvoltage	e-11
000DH	VFD overload	e-21
000EH	Motor overload	e-22
0010H	Overheat tripping	e-24
0011H	Emergency tripping	e-43
0012H	EEPROM error 1 (write error)	e-31
0013H	EEPROM error 2 (Read error)	e-31
0014H	EEPROM error 3 (Internal error)	e-31
0018H	External communication error	e-33
001AH	Current detection fault	e-34
001EH	Undervoltage	e-12

## 9. APPENDIX B: CONCISE PARAMETER LIST

[-F0-]					
NO.	Parameter Name	Setting Range	default	WRT	User setting
f000	Operation frequency of keypad	f009~f008	0.0	○	
f001	V/F control mode selection	0: V/F constant 1: Variable torque 2: Sensor-less vector control 3: Energy saving	0	●	
f002	Command mode selection 1	0: Terminal board 1: Keypad 2: Serial communication	1	●	
f003	Frequency setting mode selection 1	0: Built-in potention meter 1: AI1 input 2: AI2 input 3: Keypad(Given frequency) 4: Serial communication (Given frequency) 5: UP/DOWN setting 6: AI1+AI2 7: PID setting of keypad (PID given) 8: Simple PLC running	3	●	
f004	Command mode selection 2	0: Terminal board 1: Keypad 2: Serial communication	0	○	
f005	Frequency setting mode selection 2	0: Built-in potention meter 1: AI1 input 2: AI2 input 3: Keypad(Given frequency) 4: Serial communication (Given frequency) 5: UP/DOWN speed given 6: AI1+AI2 7: PID setting of keypad (PID given) 8: Simple PLC running option	2	○	

NO.	Parameter Name	Setting Range	default	WRT	User setting
f006	Frequency /PID given source conversion	0: Switch between f003 and f005 1: Switch is disabled 2: Switch between f003 and f021 selected frequency /PID source 3: Switch between f005 and f021 selected frequency /PID source	0	○	
f007	Maximum frequency	30.0~400.0 Hz	50.0	●	
f008	Upper limit frequency	0.5 Hz ~f007	50.0	○	
f009	Lower limit frequency	0.0 Hz ~f008	0.0	○	
f010	Acceleration time 1	0.1~3200 s	varies by model	○	
f011	Deceleration time 1	0.1~3200 s	varies by model	○	
f012	PWM carrier frequency	1.5k~12.0 kHz	varies by model	○	
f013	Carrier frequency control mode selection	0: not reduced automatically 1: reduced automatically	1	●	
f014	Random PWM mode	0: Disable. 1: Enable.	0	○	
f015	Automatic acceleration/deceleration	0: Disabled (manual). 1: Automatic (at acceleration & deceleration) 2: Automatic (only at acceleration)	0	●	
f016	Factory reserved	-	-		
F017	Parameter setting mQDo function	0: Default value. 1: 2-wire control (Negative logic mode, ramp stop). 2: 3-wire control (Negative logic mode, ramp stop). 3: External input UP/DOWN setting (Negative logic mode, slowdown stop). 4 ~ 16: Factory reserved 17: PID sleep & Wake Control (f003 =7 f910 =0.1s f911 =75.0% f915 =5.0s f919 =38.0Hz) 18: PID basic control (f002 =1 f003=7 f367=1 f523=2 f900 =1 f917=100 f918 =20) 19: Factory reserved	0	●	
f018	Factory reserved	-	-		
f020	Factory reserved	-	-		



NO.	Parameter Name	Setting Range	default	WRT	User setting
f021	Primary and secondary frequencies /PID are given	0: Single channel given 1: f003 + f005 2: f003-f005 3: MAX (f003, f005) 4: MIN (f003, f005)	0	○	
f022	f005 frequency given coefficient	0.0~ 100.0%	100.0 %		
f023	f005 frequency bias given	0.0Hz~400.0Hz	0.0Hz		
f024	Lower limit selection and f005= 3/7 setting	0~ 5	0		
f099	Factory reserved	Same as f020			

[-F1-]					
NO.	Parameter Name	Setting Range	default	WRT	User setting
f100	Auto-tuning	0: Auto-tuning disabled 1: Application of individual settings of f203 2: Auto-tuning enabled	0	●	
f101	Base frequency 1	25.0~400.0 Hz	50.0	●	
f102	Base frequency voltage1	50~660 V	varies by model	●	
f103	Motor rated current	0.1~200.0 A	varies by model	●	
f104	Motor rated speed	100~15000 rpm	varies by model	●	
f105	Motor no-load current	10.0~100.0%	varies by model	●	
f106	Motor electronic thermal protection level 1	varies by model	varies by model	○	
f107	stall prevention level 1	varies by model	varies by model	●	
f108	Base frequency 2	25.0~400.0 Hz	50.0	●	
f109	Base frequency voltage 2	50~660V	varies by model	●	
f110	Motor electronic-thermal protection level 2	varies by model	varies by model	○	
f111	Stall prevention level 2	varies by model	varies by model	○	
f112	factory reserved	-			
f113	factory reserved	-			
f114	factory reserved	-			
f115	factory reserved	-			

NO.	Parameter Name	Setting Range	default	WRT	User setting
f120	Default setting	0: - 1: Standard default setting (Initialization) 2: Save user-defined parameters 3: Call user-defined parameters 4: Trip record clear 5: Cumulative operation time clear 6: Cumulative fan operation time record clear 7: Initialization of type information 8: P-type rating. 9: G-type rating.	0	●	

[-f2-]

NO.	Parameter Name	Setting Range	default	WRT	User setting
f201	Supply voltage correction	0: Supply voltage uncorrected, output voltage limited. 1: Supply voltage corrected, output voltage limited. 2: Supply voltage uncorrected, output voltage unlimited. 3: Supply voltage corrected, output voltage unlimited.	3	●	
f202	Voltage boost 1	0.0~30.0%	varies by model	○	
f203	Torque boost	0.0~30.0%	varies by model	○	
f204	Slip frequency gain	0~150%	50	○	
f205	Exciting current coefficient	100~130	100	●	
f206	Voltage boost 2	0~30%	varies by model	○	
f207	Speed control response coefficient	1~150	40	●	
f208	Speed control stability coefficient	1~100	20	●	
f209	Stall prevention control coefficient 1	10~250	100	●	
f210	Stall prevention control coefficient 2	50~150	100	●	
f211	Maximum voltage adjustment coefficient	90~120%	104	●	
f212	Waveform switching adjustment coefficient	0.1~14kHz	14.0	●	
f213	factory reserved				
f214	factory reserved				

NO.	Parameter Name	Setting Range	default	WRT	User setting
f215	factory reserved				
f216	factory reserved				
f217	multipoint profile V/F patter	0: factory reserved. 1: factory reserved. 2: Enable multipoint profile V/F patter.	0	•	
f218	point 1 output frequency (F1)	0~f220	10.0	•	
f219	point 1 output frequency voltage (V1)	0~100%	20.0	•	
f220	point 2 output frequency (f2)	f218~f220	20.0	•	
f221	point 2 output frequency voltage (V2)	0~100%	40.0	•	
f222	point 3 output frequency (f3)	f220~f101	30.0	•	
f223	point 3 output frequency voltage (V3)	0~100%	60.0	•	

[-f3-]

NO.	Parameter Name	Setting Range	default	WRT	User setting
f300	AI1 terminal function selection	0: AI1 - analog input 1: AI1 - contact input (Sink mode) 2: AI1 - contact input (Source mode)	0	•	
f301	Input terminal function for LI1	0: No function is assigned 1: Standby terminal	2	•	
f302	Input terminal function for LI2	2: Forward run command 3: Reverse run command	3	•	
f303	Input terminal function for LI3	4: Jog run mode 5: Acceleration/deceleration 2 pattern selection	0	•	
f304	Input terminal function for LI4	6: Preset-speed command 1 7: Preset-speed command 2 8: Preset-speed command 3 9: Preset-speed command 4 10: Reset command 11: Trip stop command from external input device 13: DC braking command 14: PID control disabling 15: Permission of parameter editing 16: Combination of standby and reset commands 17: Frequency source switching to AI1 18: Combination of forward run and jog run	10	•	

NO.	Parameter Name	Setting Range	default	WRT	User setting
f304	Input terminal function for LI4	19: Combination of reverse run and jog run 20: Frequency setting source switching 21: No.2 Switching of V/F setting 22: No.2 motor switching 23: Frequency UP signal input from external contacts 24: Frequency DOWN signal input from external contacts 25: Frequency UP/DOWN cancellation signal input from external contacts 26: inversion of trip stop command from external device 27 Thermal trip stop signal input from external device 28: inversion of thermal trip stop signal input from external device 29: Forced switching from remote to local control 30: Operation holding (stop of 3-wire operation) 31: Forced switching of command mode and terminal board command 32: Display cancellation of the cumulative power amount (kWh) 33: Fire-speed control seef419 34: Coast stop (gate off) 35: Inversion of Reset 36: Forced switching of stall prevention level 2 37: PID control integral value clear PID control integral value clear 38: inversion of PID error signal 39: Forward running command + Acc&Dec curve 2 40: Reverse running command + Acc&Dec curve 2 41: Forward running command + Multi-speed section 1 42: Reverse running command + Multi-speed section 1 43: Forward running command + Multi-speed section 2 44: Reverse running command + Multi-speed section 2 45: Forward running command + Multi-speed section3 46: Reverse running command + Multi-speed section 3 47: Forward running command + Multi-speed section 4	10	•	

NO.	Parameter Name	Setting Range	default	WRT	User setting
f304	Input terminal function for LI4	48: Reverse running command + Multi-speed section 4 49: Multi-speed section 1 + Acc&Dec curve 2 50: Multi-speed section 2 + Acc&Dec curve 2 51: Multi-speed section 3 + Acc&Dec curve 2 52: Multi-speed section 4 + Acc&Dec curve 2 53: Forward running command +Multi-speed section 1+ Acc&Dec curve 2 54: Reverse running command +Multi-speed section 1+ Acc&Dec curve 2 55: Forward running command +Multi-speed section 2+ Acc&Dec curve 2 56: Reverse running command +Multi-speed section 2+ Acc&Dec curve 2 57: Forward running command +Multi-speed section 3+ Acc&Dec curve 2 58: Reverse running command +Multi-speed section 3+ Acc&Dec curve 2 59: Forward running command +Multi-speed section 4+ Acc&Dec curve 2 60: Reverse running command +Multi-speed section 4+ Acc&Dec curve 2 61: UP/DOWN speed clean up+ fault reset 62: Running permission+ Forward running command (only 2-wire control) 63: Running permission+ reverse running command (only 2-wire control) 64: Acc&dec curve 3 65: Acce/Dece curve 3 + Forward running command 66: Acce/Dece curve 3 + Reverse running command 67: Command source switch 68: Command source + frequency source switch 69: Three-wire control stop reverse 70: Reset when simple PLC stops 71: Simple PLC time out 72: Simple PLC pause 73/74: PID control + frequency given source switch 75:(UP/DOWN) stop speed clearance	10	•	

NO.	Parameter Name	Setting Range	default	WRT	User setting
f305	AI1 voltage-current input selection	0:0~5V voltage signal input. 1:0~10V voltage signal input. 2: 0-20mA(4-20mA) current signal input.	0	•	
f306	sink/soruce mode selection	0: Source (Positive) logic terminal mode. 1: Sink (Negative) logic terminal mode	1	•	
f307	AO voltage-current output selection	0: Current signal output. 1: Voltage signal output.	1	•	
f308	Input terminal function of AI1	f301~f304	0	•	
f309	Always-active terminal selection 1	f301~f304	1	•	
f310	Always-active terminal selection 2	f301~f304	0	•	
f311	Output terminal function A of LO1-CLO1	f315	4	•	
f312	Output terminal function B of LO1-CLO1	f315	255	•	
f313	AI2 terminal function selection	0: AI2 - analog input 1: AI2 - contact input (Sink) 2: AI2 - contact input (Source)	0	•	
f314	Input terminal function of AI2	f301~f304	0	•	
f315	Output terminal function A of T1 (T1A-T1B-T1C)	0: Output frequency higher than lower limit frequency 2: Output frequency equals to upper limit frequency 4: Output frequency is higher or equal to f337 6: (set frequency -f339)<output frequency<(set frequency+f339) 8: (f338-f339) < output frequency < (f338+f339) 10: Output frequency higher or equal to f338+f339 12: F003 or F005 source supply given speed=AI1 signal 14: F003 or F005 source supply given speed=AI2 signal 16: AI1's value higher or equal to f340+f341 18: AI2's value is higher or equal to f342+f343	40	•	

NO.	Parameter Name	Setting Range	default	WRT	User setting
f315	Output terminal function A of T1 (T1A-T1B-T1C)	20: AI2 is the speed given source 22: VFD forward motor power supply (acceleration, deceleration, constant speed or DC braking) 24: Ready for running of the VFD (running permission and running command available) 26: Motor reverse running 28: Under local mode for VFD 30: Fault happened in the VFD 32: Evaluated motor torque is at f412 level time is still less than f414 set value. 34: Motor current is less than f408 and its lasting time is over f410 setting. 36: Fault occurred and could not reset. 38: Fault occurred but it could reset. 40: Fault occurs in the VFD 42: Alarm occurs 44: Motor heating status has reached 50% of motor overload fault level. 46: DC braking resistor status has reached 50% DC braking resistor overload fault level. 48: Evaluated motor torque reaches f412*70% 50: Run time≥f428 set value 52: The equipment sends maintenance alarm warning. (Fan, PCB or capacitor needs replacement.) 54: PTC heating sensor needle has detected motor temperature reaching 60% of trip level. 56: Undervoltage alarm is valid. 58: Brake pull 60: In the process of motor acceleration process 62: In the process of motor deceleration	40	•	

NO.	Parameter Name	Setting Range	default	WRT	User setting
f315	Output terminal function A of T1 (T1A-T1B-T1C)	64: In the process of motor deceleration or acceleration 66: Heat sink temperature has reached alarm value 68: One PLC recycle completes 70: One PLC speed section completes 72: The inverter is ready to receive the running signal 74~79: unused 80: LI1 input is valid 82: LI2 input is valid 84: PID feedback pressure equal to or higher than f627 + f628 86: PID feedback pressure equal to or higher than f918 + f628 88~253: Unused 254: Relay constant output OFF 255: Relay constant output ON	40	●	
f316	Output terminal logic selection of LO1-CLO1	0: And logic 1: Or logic	0	●	
f317	LO1-CLO1 output delay	0.0~60.0 s	0.0	○	
f318	Relay 1 closing delay	0.0~60.0 s	0.0	○	
f319	External contact input - UP response time	0.0~10.0 s	0.1	○	
f320	External contact input - UP frequency steps	0.0 Hz ~f007	0.1	○	
f321	External contact input - DOWN response time	0.0~10.0 s	0.1	○	
f322	External contact input - DOWN frequency steps	0.0 Hz ~f007	0.1	○	
f323	Initial up/down frequency	0.0 Hz ~f007	0.0	○	
f324	Change of the initial up/down frequency	0/2/4: disabled 1/3/5: enabled	1	○	
f325	AI1 input point 1 setting	0~100%	0	○	
f326	AI1 input point 1 frequency	0.0~400.0 Hz	0.0	○	
f327	AI1 input point 2 setting	0~100%	100	○	
f328	AI1 input point 2 frequency	0.0~400.0 Hz	50.0	○	
f329	AI2 input point 1 setting	0~100%	0	○	
f330	AI2 input point 1 frequency	0.0~400.0 Hz	0.0	○	



NO.	Parameter Name	Setting Range	default	WRT	User setting
f331	AI2 input point 2 setting	0~100%	50	○	
f332	AI2 input point 2 frequency	0.0~400.0 Hz	50.0	○	
f333	AI1 input bias	0~255	varies by model	○	
f334	AI1 input gain	0~255	varies by model	○	
f335	AI2 input bias	0~255	varies by model	○	
f336	AI2 input gain	0~255	varies by model	○	
f337	Low-speed signal output frequency	0.0 Hz ~f007	0.0	○	
f338	Speed reach detection output frequency	0.0 Hz ~f007	0.0	○	
f339	Speed reach detection band	0.0 Hz ~f007	2.5	○	
f340	AI1 input reach detection level	0~100%	0	○	
f341	AI1 input reach detection band	0~20%	3	○	
f342	AI2 input reach detection level	0~100%	0	○	
f343	AI2 input reach detection band	0~20%	3	○	
f344	Frequency command agreement detection range	0.0 Hz ~f007	2.5	○	
f345	Logic output/pulse train output selection (LO1-CLO1)	0: Logic output 1: Pulse train output	0	●	
f346	Pulse train output function selection (LO - CLO)	0: Output frequency 1: Output current 2: Set frequency (Before PID) 3: Frequency setting value (After PID) 4: DC voltage 5: Output voltage command value 6: Input power 7: Output power 8: AI1 Input value 9: AI2 Input value 10: Torque 11: Torque current 12: Motor cumulative load factor 13: Inverter cumulative load factor 14: PBR (braking reactor) cumulative load factor	0	○	

NO.	Parameter Name	Setting Range	default	WRT	User setting
f347	Maximum numbers of pulse train	500~1600	800	○	
f348	AO1 selection	0:Output frequency 1:Output current 2:Set frequency (before PID) 3:Frequency setting value (after PID) 4:DC voltage 5:Output voltage command value 6:Input power 7:Output power 8:AI1 input 9:AI2 input 10:Torque 11:Torque current 12:Motor cumulative load factor 13:Inverter cumulative load factor 14:brake resistor cumulative load factor 15:Serial communication data 16:185% proofread 17:150% proofreading 18.100% proofread	0	○	
f349	AO1 gain adjustment	1~1280	varies by model	○	
f350	Inclination characteristic of analog output	0: Negative 1: Positive	1	○	
f351	Bias of analog output	0~100%	0	○	
f352	output frequency when AO1 = 0V	0 Hz ~F007	0.0	○	
f353	output frequency when AO1 = 10V	0 Hz ~F007	0.0	○	
f354	AO1 bias	0~255	128	○	
f355	Analog Output Voltage Bias Calibration (AO1)	f301~f304 (15kW and above)	0	●	
f356	Input terminal function for LI6	f301~f304 (15kW and above)	0	●	
f357	Input terminal function for LI7	f301~f304 (15kW and above)	0	●	
f358	Input terminal function for LI8	f301~f304 (15kW and above)	0	●	
f359	Output terminal function A of T2	See f315	0	●	
f360	Relay 2 auxiliary functions	See f315	255	●	
f361	Output terminal logic selection of T2	0: And Logic (15kW and above) 1: Or Logic	0	●	

NO.	Parameter Name	Setting Range	default	WRT	User setting
f362	Relay 2 closing delay	0~60.0s (15kW and above)	0.0	●	
f363	Input terminal active mode	8 bits - hexadecimal display, each option: 0: Closure is valid 1: Disconnect effective			
f364	Logical input terminal filtering	0~200	0		
f365	Relay output 1 assistant function	f315	255		
f366	Relay output 1 function logic relation	0~1	0		
f367	Terminal run detection selection at power on	0: disable 1: enable	0		
f368	Analog output signal type (AO2)	0: Current signal output 1: Voltage signal output	1	●	
f369	Analog output function selection (AO2)	f348	0	○	
f370	Analog output current scaling (AO2)	1~1280	Based on machine model	○	
f371	AO2 Analog output slope	0: Negative slope 1: Positive slope	1	○	
f372	AO2 Analog output bias	0~100%	0	○	
f373	Analog Output current Bias Calibration (AO2)	0~255	4	●	
f374	Percentage of AO monitored values	0~250%	0	●	
f375	Relay 1 disconnect delay	0~60.0s	0.0	●	
f376	Relay 2 disconnect delay	0.0~60.0s	0.0	●	

[-f4-]					
NO.	Parameter Name	Setting Range	default	WRT	User setting
f400	Retry selection	0: disabled 1~10 times.	0	●	
f401	Electronic-thermal protection characteristic selection	0: Trip enable, stall disable (standard motor) 1: Trip enable, stall enable (standard motor) 2: Trip disable, stall disable (standard motor)	0	○	

NO.	Parameter Name	Setting Range	default	WRT	User setting
f401	Electronic-thermal protection characteristic selection	3: Trip disable, stall enable (standard motor) 5: Trip enable, stall disable (forced cooling motor) 6: Trip enable, stall enable (forced cooling motor) 7: Trip disable, stall disable (forced cooling motor) 8: Trip disable, stall enable (forced cooling motor)	0	○	
f402	Motor 150%-overload time limit	10-2400 s	300	○	
f403	Emergency stop selection	0: Coast stop 1: Slowdown stop 2: Emergency DC braking	0	●	
f404	emergency braking time	0.0-20.0 s	1.0	○	
f405	Input phase failure detection	0: Disabled, No tripping. 1: Enabled	0	●	
f406	Output phase failure detection mode selection	0: Disabled 1: At start-up (Only one time after power is turned on) 2: At start-up (each time) 3: During operation 4: At start-up + during operation 5: Detection of cutoff on output side	0	●	
f407	Small current trip/alarm selection	0: Alarm 1: trip	0	○	
f408	Small current detection current	0~100%	0.00	○	
f409	Small current detection current hysteresis	1~20%	10	○	
f410	Small current detection time	0-255 s	0	○	
f411	Over-torque trip/Overcurrent indication	0: Over-torque alarm (70%) 1: Over-torque fault 2: Over-torque alarm (100%) 3: Over-current alarm (70%) 4: Overcurrent fault 5: Overcurrent alarm (100%)	0	○	
f412	Over-torque detection level	0~250%	130	○	
f413	Over-torque detection level hysteresis	0~100%	10	○	
f414	Over-torque detection time	0.0~10.0 s	0.5	○	
f415	Overvoltage limit operation	0: Enabled. speed. 1: Disabled 2: Enabled (Quick deceleration). 3: Enabled (Dynamic quick deceleration).	2	●	

NO.	Parameter Name	Setting Range	default	WRT	User setting
f416	Overvoltage limit operation level	100-150%	130	●	
f417	Undervoltage trip/alarm selection	0: Alarm only (detection level below 60%) 1: Tripping (detection level below 60%). 2: Alarm only (detection level below 50%)	0	●	
f418	Instantaneous power failure coast stop selection	0: disabled 1: factory reserved 2: Coast stop.	0	●	
f419	Forced fire-speed control function	0: Disabled. 1: Enabled.	0	○	
f420	Detection of output short-circuit during start-up	0: Each time (standard pulse) 1: Only one time after power is turned on (standard pulse) 2: Each time (short-time pulse) 3: Only one time after power is turned on (short-time pulse)	0	●	
f421	Motor electric-thermal protection retention selection	0: disabled. 1: Enabled.	0	○	
f422	AI1 input loss	1~100%	0	○	
f423	Activation of the VFD during 4-20mA signal loss	0: No measures. 1: Coast stop. 2: switch to Fallback speed. 3: Speed maintaining. 4: Slowdown stop.	0	●	
f424	Fallback speed	0.0 Hz ~f007	0.0	○	
f425	PTC thermal selection	0: Disabled 1: Enabled (trip mode) 2: Enabled (alarm mode)	0	○	
f426	Resistor value for PTC detection	100-9999Ω	3000	○	
f428	Cumulative operation time alarm setting	0.0-999.9 h (0.1=10 hour)	610.0	○	
f429	VFD trip retention selection	0: clearing 1: maintaining	0	○	
f430	Heat sink temperature reaches the alarm value	0 ~100℃	60	●	
f431	Analog output current scaling (AO1)	1~1280			
f432	Analog Output current Bias Calibration (AO1)	0~255			
f433	Analog output voltage scaling (AO2)	1~1280			
f434	Analog Output Voltage Bias Calibration (AO2)	0~255			

[-f5-]					
NO.	Parameter Name	Setting Range	default	WRT	User setting
f500	Auto-restart control selection	0: Disabled 1: At auto-restart after momentary stop 2: When turning standby (input terminal function =1) on or off 3: At auto-restart or when turning standby (input terminal function =1) on or off 4: At start-up 5~7: Factory reserved 8: DC braking and then start.	0	●	
f501	auto-stop time limit for lower-limit frequency operation	0.0: disable 0.1-600.0 s	0.1	○	
f502	Bumpless operation selection	0: disabled. 1: enabled.	1	○	
f503	Starting frequency setting	0.5~10.0 Hz	0.5	○	
f504	Operation starting frequency	0.0 Hz ~f007	0.0	○	
f505	Operation starting frequency hysteresis	0.0 Hz ~f007	0.0	○	
f506	DC braking starting frequency	0.0 Hz ~f007	0.0	○	
f507	DC braking current	varies by model	varies by model	○	
f508	DC braking time	0.0~20.0 s	1.0	○	
f510	Acceleration/deceleration 1 pattern	0: Linear 1: S pattern 1 2: S pattern 2 3: Elevator acceleration / deceleration curve	0	○	
f511	Acceleration/deceleration 2 pattern	0: Linear 1: S pattern 1 2: S pattern 2	0	○	
f512	Acceleration/deceleration 3 pattern	0: Linear 1: S pattern 1 2: S pattern 2	0	○	
f513	Acceleration/deceleration 1 and 2 switching frequency	0.0 Hz ~f008	0.0	○	
f514	Acceleration/deceleration 2 and 3 switching frequency	0.0 Hz ~f008	0.0	○	
f515	Selecting an acceleration/deceleration pattern	1: Acc/Dec 1 2: Acc/Dec 2 3: Acc/Dec 3	1	○	

NO.	Parameter Name	Setting Range	default	WRT	User setting
f516	S-pattern lower-limit adjustment amount	0~50%	10	○	
f517	S-pattern upper-limit adjustment amount	0~50%	10	○	
f518	Acceleration time 2	0.0~3200 s	20.0	○	
f519	Deceleration time 2	0.0~3200 s	20.0	○	
f520	Acceleration time 3	0.0~3200 s	20.0	○	
f521	Deceleration time 3	0.0~3200 s	20.0	○	
f522	Reverse-run prohibition	0: Forward/reverse run permitted. 1: Reverse run prohibited. 2: Forward run prohibited.	0	●	
f523	stop type	0: Ramp shutdown 1: Free shutdown of keyboard 2: 2 line control free stop 3: 2 line control free stop	2	○	
f526	Positive and negative operation is preferred	0: Forward + reverse -&gt;reverse 1: forward + reverse -& GT;downtime 2: Forward + reverse -& GT;Let me give you the direction 3: Forward + reverse -& GT;In the direction given by 4: Forward + reverse -& GT;positive	1	○	
f527	regenerative braking selection	0: Disabled 1: Enabled (with resistor overload protection) 2: Enabled (without resistor overload protection)	2		
f528	regenerative braking resistance	1.0~1000.0Ω	20.0	●	
f529	regenerative braking resistor capacity	0.01~30.0 kW	0.12	●	
f530	Positive and negative dead zone time	0.0~25.0s	10	○	
f531	Acceleration / deceleration S - curve upper limit 2	0~50 %	10	●	
f532	Acceleration / deceleration S - curve lower limit 3	0~50 %	10	●	
f533	Acceleration / deceleration S - curve upper limit 3	0~50 %	10	●	

[-f6-]					
NO.	Parameter Name	Setting Range	default	WRT	User setting
f600	Prohibition of panel reset operation	0: Permitted 1: Prohibited	0	○	
f601	Switching between remote control and Local control	0: Local control mode 1: remote control mode 2. JOG function is set with f700	1	○	
f602	Password check/input	0~9999	0	○	
f603	Current/voltage display mode	0: % 1: A (ampere)/V (volt),	1	○	
f604	Frequency free unit magnification	0: unit is Hz 0.01-200.0: free unit	0.00	○	
f605	Factory reserved	-	0	●	
f606	Inclination characteristic of free unit display	0: Negative inclination (downward slope) 1: Positive inclination (upward slope)	1	○	
f607	Bias of free unit display	0.00 Hz ~f007	0.00	○	
f608	Free step 1 (pressing a panel key once)	Disabled: 0.00 Enabled: 0.01 Hz~f007	0.00	○	
f609	Free step 2 (panel display)	0: disabled 1~255: enabled	0	○	
f610	Standard monitor display selection	0: Output frequency(Hz(free)) 1: Frequency command(Hz(free)) 2:Output current(%/A) 3:VFD rated current (A) 4:VFD load (%) 5:Output power (kW) 6: Stator frequency (Hz (free)) 7:communication data display 8: Output speed 9: Communication counter 10: Normal communication counter 11: Stop - given frequency (f900 =0)/given PID (f900 ≠0), Run - output frequency	0	○	
f611	panel running order clear selection	0: clear 1: keep	1	○	
f612	Panel operation prohibition (F000)	0: Permitted 1: Prohibited	0	○	
f613	Prohibition of panel operation (RUN/STOP keys)	0: Permitted. 1: Prohibition.	0	○	
f614	Prohibition of panel emergency stop operation	0: Permitted. 1: Prohibition. 2: No alarm during terminal emergency stop, panel emergency stop is enabled. 3: No alarm during terminal emergency stop, panel emergency stop is disabled.	0	○	



NO.	Parameter Name	Setting Range	default	WRT	User setting
f616	Integral output power retention selection	0: (clear) 1: (memory)	1	○	
f617	Integral output power display unit selection	0: 1kWh. 1: 10kWh. 2: 100kWh. 3: 1000kWh.	varies by model	○	
f618	Search and resetting of changed parameters selection	0: disable 1: enable	0	○	
f619	factory reserved	Frequency converter internal temperature monitoring 1			
f620	factory reserved	Frequency converter internal temperature monitoring 2			
f621	LCD contrast control	15~40	25		
f622	factory reserved				
f623	Bit0: Fan self-running	0: The fan works when the converter is running 1: The fan works when the inverter is powered on	0	○	
	Bit1: Positive power monitoring	0: Monitoring both positive and negative power 1: Monitor only positive power			
f624	Keyboard panel displays 2	Same as f610	2	○	
	Quick Monitoring 1	Same as f610			
f625	Keyboard panel displays 3	Same as f610	1	○	
	Quick Monitoring 2	1 ~ 8: see f610 9: PID is given 10: PID feedback			
f626	Keyboard panel displays 4	Same as f610	5	○	
	Quick Monitoring 2	1 ~ 8: see f610 9: PID is given 10: PID feedback			
f627	Relay output -PID feedback check out	0.00~99.99	0.00		
f628	Relay output -PID feedback to detect bandwidth	0.00~99.99	0.00		
f629	Factory reserved				

[-f7-]					
NO.	Parameter Name	Setting Range	default	WRT	User setting
f700	JOG key function setting	0~6	5	○	
f701	jog run frequency	0.0~20.0 Hz	5.0	○	
f702	Jog stopping pattern	0: Slow down stop. 1: coast stop. 2: DC braking.	0	●	
f703	Jump frequency 1	0.0 Hz ~f007	0.0	○	
f704	Jumping width 1	0.0 ~30.0 Hz	0.0	○	
f705	Jump frequency 2	0.0 Hz ~f007	0.0	○	
f706	Jumping width 2	0.0~30.0 Hz	0.0	○	
f707	Jump frequency 3	0.0 Hz ~f007	0.0	○	
f708	Jumping width 3	0.0~30.0 Hz	0.0	○	
f709	Braking mode selection	0~3	0	●	
f710	Release frequency	f503~20.0Hz	3.0	○	
f711	Release time	0~25.0s	0.5	○	
f712	Creeping frequency	f503~20.0Hz	3.0	○	
f713	Creeping time	0~25.0s	1.0	○	
f714	Droop gain	0~100%	0	○	
f715	Droop insensitive torque band	0~100%	10	○	
f716	Preset-speed 1	f009~f008	3.0	○	
f717	Preset-speed 2	f009~f008	6.0	○	
f718	Preset-speed 3	f009~f008	9.0	○	
f719	Preset-speed 4	f009~f008	12.0	○	
f720	Preset-speed 5	f009~f008	15.0	○	
f721	Preset-speed 6	f009~f008	18.0	○	
f722	Preset-speed 7	f009~f008	21.0	○	
f723	Preset-speed 8	f009~f008	24.0	○	
f724	Preset-speed 9	f009~f008	27.0	○	
f725	Preset-speed 10	f009~f008	30.0	○	
f726	Preset-speed 11	f009~f008	33.0	○	
f727	Preset-speed 12	f009~f008	36.0	○	
f728	Preset-speed 13	f009~f008	39.0	○	
f729	Preset-speed 14	f009~f008	45.0	○	
f730	Preset-speed 15	f009~f008	50.0	○	
f731	factory reserved				
f732	Multi-speed 0 run time	0~65000.0s(min)	0.0		
f733	Multi-speed 1 run time	0~65000.0s(min)	0.0		

NO.	Parameter Name	Setting Range	default	WRT	User setting
f734	Multi-speed 2 run time	0~65000.0s(min)	0.0		
f735	Multi-speed 3 run time	0~65000.0s(min)	0.0		
f736	Multi-speed 4 run time	0~65000.0s(min)	0.0		
f737	Multi-speed 5 run time	0~65000.0s(min)	0.0		
f738	Multi-speed 6 run time	0~65000.0s(min)	0.0		
f739	Multi-speed 7 run time	0~65000.0s(min)	0.0		
f740	Multi-speed 8 run time	0~65000.0s(min)	0.0		
f741	Multi-speed 9 run time	0~65000.0s(min)	0.0		
f742	Multi-speed 10 run time	0~65000.0s(min)	0.0		
f743	Multi-speed 11 run time	0~65000.0s(min)	0.0		
f744	Multi-speed 12 run time	0~65000.0s(min)	0.0		
f745	Multi-speed 13 run time	0~65000.0s(min)	0.0		
f746	Multi-speed 14 run time	0~65000.0s(min)	0.0		
f747	Multi-speed 15 run time	0~65000.0s(min)	0.0		
f732	Multi-speed 0 run time	0~65000.0s(min)	0.0		
f733	Multi-speed 1 run time	0~65000.0s(min)	0.0		
f734	Multi-speed 2 run time	0~65000.0s(min)	0.0		
f735	Multi-speed 3 run time	0~65000.0s(min)	0.0		
f736	Multi-speed 4 run time	0~65000.0s(min)	0.0		
f737	Multi-speed 5 run time	0~65000.0s(min)	0.0		
f738	Multi-speed 6 run time	0~65000.0s(min)	0.0		
f739	Multi-speed 7 run time	0~65000.0s(min)	0.0		
f740	Multi-speed 8 run time	0~65000.0s(min)	0.0		
f741	Multi-speed 9 run time	0~65000.0s(min)	0.0		
f742	Multi-speed 10 run time	0~65000.0s(min)	0.0		
f743	Multi-speed 11 run time	0~65000.0s(min)	0.0		
f744	Multi-speed 12 run time	0~65000.0s(min)	0.0		
f745	Multi-speed 13 run time	0~65000.0s(min)	0.0		
f746	Multi-speed 14 run time	0~65000.0s(min)	0.0		
f747	Multi-speed 15 run time	0~65000.0s(min)	0.0		
f748	PLC speed direction option	0~65535	0		
f749	Simple PLC running mode	0: run one time and then stop 1: run one time and keep running at the final value 2: recycle running	0		
f750	Simple PLC restart mode selection	0: start running from the first phase 1: keep running from the interrupt frequency	0		

NO.	Parameter Name	Setting Range	default	WRT	User setting
f751	Simple PLC Power drop memory selection	0: no memory for power drop 1: memory for power drop	0		
f752	Simple PLC running time unit selection	0: second (s) 1: min	0		
f753	Nonstandard function selection	0~65535	0	○	
f754	AI1 curve selection	0: Curve (Point 2) 1: Curve (Point 4)	0	○	
f755	AI1 curve 2 set point 1 input	0.0 ~ 100.0%	0.0%	○	
f756	AI1 curve 2 sets point 1 output	-100% ~ 100%	0.0%	○	
f757	AI1 curve 2 set point 2 input	0.0 ~ 100.0%	30.0%	○	
f758	AI1 curve 2 sets point 2 output	-100% ~ 100%	30.0%	○	
f759	AI1 curve 2 set point 3 input	0.0 ~ 100.0%	60.0%	○	
f760	AI1 curve 2 sets point 3 output	-100% ~ 100%	60.0%	○	
f761	AI1 curve 2 set point 4 input	0.0 ~ 100.0%	100.0%	○	
f762	AI1 curve 2 sets point 4 output	-100% ~ 100%	100.0%	○	
f763	LI1 effective delay	6500.0 ~ 0.0 s	0.0	○	
f764	LI1 invalid delay	6500.0 ~ 0.0 s	0.0	○	
f765	LI2 effective delay	6500.0 ~ 0.0 s	0.0	○	
f766	LI2 invalid delay	6500.0 ~ 0.0 s	0.0	○	
f767	AI1 filtering coefficient	0.00 -10.00	0.30	○	
f768	AI2 filtering coefficient	0.00 -10.00	0.30	○	
f769	AO1 filtering coefficient	0.00 -10.00	0.00	○	
f770	AO2 filtering coefficient	0.00 -10.00	0.00	○	
f772	Password Setting	0~9999	0	○	
f773	Password duration	0~9999 min	5	○	
f813	Module writes data 1	0: Off 1: Communication command control (FA05) 2: Reservations	1	○	
f814	Module writes data 2	3: Communication frequency setting (FA08) 4 ~ 6: reservations	3	○	

NO.	Parameter Name	Setting Range	default	WRT	User setting
f815	Module dates read 1	0: Off 1: Status Information (FD03) 2: Output frequency (FD12) 3: Output current (FE08) 4: Output voltage (FE10) 5: Fault information (FC39)	1	○	
f816	Module dates read 2	6: PID feedback value (FA36) 7: Input terminal information (FD01) 8: Output terminal information (FD02) 9: AI1 input (FE30) 10: AI2 input (FE31) 11: Motor speed (FE50)	2	○	
f817	Module dates read 3	12: Absolute value of output current (e002), unit 0.01a 13: Absolute value of output voltage (e006), unit V 14: Absolute value of input voltage of DC bus (e009), unit V	12	○	
f818	Module dates read 4	15: PID given value (FA35) 16: Output torque (FE20), 0.01% of rated torque per unit motor 17: Input power (FE28), 0.01kW 18: Output power (FE29), 0.01kW 19: Input power accumulation/input electric energy (FE44), the unit is determined according to the parameter f617	18	○	
f819	Module dates read 5	20: Output power accumulation/output electric energy (FE45), the unit is determined according to the parameter f617 21: Cumulative running time (FE17), unit h (hours)	8	○	

[-f8-]					
NO.	Parameter Name	Setting Range	default	WRT	User setting
f800	Modbus baud rate	0: 9600 bps 1: 19200 bps 2: 4800 bps 3: 2400 bps 4: 1200 bps	1	○	
f801	Modbus parity	0: NONE 1: EVEN 2: ODD	1	○	
f802	Modbus address	0-247	1	○	



NO.	Parameter Name	Setting Range	default	WRT	User setting
f803	Modbus timeout	0: timeout check disabled. 1-100s	0	○	
f804	Modbus transger waiting time	0~2.00 s	0.00	○	
f805	Modbus behaviour on communication fault	0: VFD stop, communication command, frequency mode open(by F002, F003) 1: None (continued operation) 2: Deceleration stop 3: Coast stop 4: Communication error (e-33 trip) or Network error (e-35 trip)	4	○	
f806	Number of motor poles for communication	1~8	2	○	
f821	factory reserved				
f822	factory reserved				
f823	factory reserved				
f824	factory reserved				
f825	factory reserved				
f826	factory reserved				
f827	factory reserved				
f828	factory reserved				
f829	factory reserved				
f830	PID setting of keypad	0~100%	0.0	○	

[-f9-]					
NO.	Parameter Name	Setting Range	Default	WRT	User setting
f900	PID control setting	0: Disabled, 1: Enabled (Feedback: AI1) 2: Enabled (Feedback: AI2)	0	○	
f901	Proportional gain (P control)	0.01~100.0	varies by model	○	
f902	Integral gain	0.01~100.0	varies by model	○	
f903	Differential gain	0.00~2.55	0.00	○	
f904	PID control waiting time	0~2400 s	0	○	
f905	PID regulator diviation input signal negation/Direction	0: disable/Direct action 1: enable/Reaction	0	○	
f906	Sleep mode awakening hysteresis bandwidth	0.0 Hz ~f007	0.2	○	
f907	Sleeping mode awakening threshold based on PI deviation	0.0 Hz ~f917	0.0	○	

NO.	Parameter Name	Setting Range	default	WRT	User setting
f908	Sleeping mode awakening threshold based on PI feedback	0.0 Hz ~f917	0.0	○	
f909	sleeping mode action	0: Motor slowdown to a stop. 1: Motor keep running at lower limit frequency.	0	●	
f910	wake up delay	0~600.0s	0.0	●	
f911	Auto wake up level	0~200.0%	0.0	○	
f912	Auto sleep level	0~200.0%	100	○	
f913	Upper limit of PID setting	0~100%	100	●	
f914	Lower limit of PID setting	0~f913	0	●	
f915	Delay control of sleep mode	Disable: 0.0 Enable: 0.1-600.0 s	0.1	○	
f916	PID control deviation limit	0~100%	0.0	○	
f917	Sensor range	0.00~99.99	1.00		
f918	PID adjustment	0.00~f917	0.00		
f919	Sleeping frequency	0.0Hz~f008	0.0		
f920	Sleeping threshold tolerance	0.0~25.0%	0.0		

Note 1: in the volume of "WRT", "○": means writable at stop or running status.; "●": means unwritable at stop or running status;

Note 2: we can obtained modbus parameter address by replacing 'F' of '0'. E.g. f908's address is 0x0908.

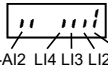
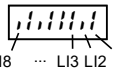
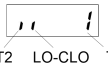
NO.	Parameter Name	Description
u000	CPU1 Version	E.g:  100, G-type, v= g; P-type, v= p;
u001	Operation frequency	Value is displayed in Hz/free unit. See f604.
u002	Direction of rotation	 Forward run,  Reverse run.
u003	frequency command value	Value is displayed in Hz/free unit. See f604.
u004	load current	The VFD output current (%/A) is displayed.
u005	input voltage (AC RMS)	The VFD input voltage (%/V) is displayed.
u006	output voltage (AC RMS)	The VFD output voltage command (%/V) is displayed.
u007	Input terminal status indicated	11kW or below:  i: OFF i: ON A11-A12 L14 L13 L12 L11 15kW or above:  i: OFF i: ON L18 ... L13 L12 L11
u008	Output terminal status indicated	 i: OFF i: ON T2 LO-CLO T1, without T2 at 11kW or below
u009	cumulative operation time	(0.01=1 hour, 1.00=100 hours)

NO.	Parameter Name	Description
u010	Output speed	Displays the motor speed ( min-1) by calculating with output frequency and pole numbers.
u011	Rated current	The rated current of the VFD (A) is displayed.
u012	Torque current	The torque current (%/A) is displayed.
u013	Load current	The VFD output current (load current) (%/A) is displayed.
u014	Torque	The torque (%) is displayed.
u015	Input power	The VFD input power (kW) is displayed.
u016	Output power	The VFD output power (kW) is displayed.
u017	PID feedback	The PID feedback value is displayed. (Hz/free unit)
u018	Frequency command value (PID-computed)	The PID-computed frequency command value is displayed. (Hz/free unit)
u019	Integral input power	The integrated amount of power (kWh) supplied to the VFD is displayed.
u020	Integral output power	The integrated amount of power (kWh) supplied from the VFD is displayed.
u021	Communication counter	Displays the counter numbers of communication through the network.
u022	Normal state communication counter	Displays the counter numbers of communication only at normal state in the all communication through network.
u023	Cpu2 version	
u024	Parts replacement alarm information	
u025	Cpu1 revision	
u026	PID setting	Displayed in % term.
u027	PID feedback	Displayed in % term.
u1--	Past trip 1	Enter into the display of detailed information on past trip 1
u2--	Past trip 2	Enter into the display of detailed information on past trip 2
u3--	Past trip 3	Enter into the display of detailed information on past trip 3
u4--	Past trip 4	Enter into the display of detailed information on past trip 4



## 10. APPENDIX C: BRAKE UNIT/RESISTANCE SELECTION

When the motor needs to decelerate quickly or accurately in the transmission application, in order to obtain the required braking torque and avoid excessive pump-up voltage during deceleration that affects the safe operation of the equipment, a braking unit and a braking resistor are required to release the energy fed back to the DC bus. This series of inverters with a capacity of 37kW or less (inclusive) have built-in braking units, while models with a capacity of 45kW or more require external braking units. When braking is required, please select the appropriate braking unit and braking resistor according to the inverter capacity and specific working conditions. Under normal working conditions, the braking resistor can be selected according to the configuration in Table B.1.

Model	Brake unit		Brake resistance		
	Description	QTY	VALUE	POWER	QTY
RVE32-T3-0R7G/1R5P	BUILD-IN	1	750 Ω	110W	1
RVE32-T3-1R5G/2R2P		1	400 Ω	260W	1
RVE32-T3-2R2G/3P		1	250 Ω	320W	1
RVE32-T3-3G/4P		1	250 Ω	320W	1
RVE32-T3-4G/5R5P		1	150 Ω	400W	1
RVE32-T3-5R5G/7R5P		1	100 Ω	520W	1
RVE32-T3-7R5G/11P		1	75 Ω	1040W	1
RVE32-T3-11G/15P		1	50 Ω	1040W	1
RVE32-T3-15G/18P		1	40 Ω	1500W	1
RVE32-T3-18G/22P		1	40 Ω	1500W	1
RVE32-T3-22G/30P		1	20 Ω	8kW	1
RVE32-T3-30G/37P		1	20 Ω	8kW	1
RVE32-T3-37G/45P		1	13.6 Ω	10kW	1
RVE32-T3-45G/55P		CBU4045	1	13.6 Ω	10kW
RVE32-T3-55G/75P	CBU4055	1	12 Ω	12kW	1
RVE32-T3-75G/90P	CBU4075	1	10 Ω	20kW	1
RVE32-T3-90G/110P	CBU4110	1	6.8 Ω	30kW	1
RVE32-T3-110G/132P		1	6.8 Ω	30kW	1
RVE32-T3-132G/160P	CBU4160	1	5 Ω	40kW	1
RVE32-T3-160G/185P		1	5 Ω	40kW	1
RVE32-T3-185G/200P	CBU4220	1	3.2 Ω	60kW	1
RVE32-T3-200G/220P		1	3.2 Ω	60kW	1
RVE32-T3-220G/250P		1	3.2 Ω	60kW	1
RVE32-T3-250G/280P	CBU4300	1	2.5 Ω	80kW	1
RVE32-T3-280G/315P		1	2.5 Ω	80kW	1
RVE32-T3-315G/355P		1	2.5 Ω	80kW	1

Model	Brake unit		Brake resistance		
	Description	QTY	VALUE	POWER	QTY
RVE32-T3-355G	CBU4220	2	3.2 Ω	60kW	2
RVE32-T3-400G		2	3.2 Ω	60kW	2
RVE32-T3-500G	CBU4300	2	2.5 Ω	80kW	2
RVE32-T3-560G	CBU4220	3	3.2 Ω	60KW	3
RVE32-T3-630G	CBU4220	3	3.2 Ω	60KW	3
RVE32-T3-710G	CBU4220	3	3.2 Ω	60KW	3
RVE32-T3-800G	CBU4220	3	3.2 Ω	60KW	3

Note 1: Please select the resistance and power of the brake resistor according to the data provided by our company.

Note 2: The above table is designed for the resistor power based on 100% braking torque and 10% braking utilization rate. If the user wants a larger braking torque, the resistance of the brake resistor can be appropriately reduced and its power can be amplified.

Note 3: For occasions where frequent braking is required, the power of the brake resistor needs to be appropriately increased according to the specific working conditions.



